

# Multiple Parton Scattering in Nuclei: Quark-quark Scattering

Andreas Schäfer,<sup>a</sup> Xin-Nian Wang<sup>b</sup> and Ben-Wei Zhang<sup>c,d,a</sup>

<sup>a</sup>*Institut für Theoretische Physik, Universität Regensburg  
D-93040 Regensburg, Germany*

<sup>b</sup>*Nuclear Science Division, MS 70R0319  
Lawrence Berkeley National Laboratory, Berkeley, CA 94720*

<sup>c</sup>*Cyclotron Institute and Physics Department, Texas A&M University  
College Station, Texas 77843-3366*

<sup>d</sup>*Institute of Particle Physics, Central China Normal University  
Wuhan 430079, China*

---

## Abstract

Modifications to quark and antiquark fragmentation functions due to quark-quark (antiquark) double scattering in nuclear medium are studied systematically up to order  $\mathcal{O}(\alpha_s^2)$  in deeply inelastic scattering (DIS) off nuclear targets. At the order  $\mathcal{O}(\alpha_s^2)$ , twist-four contributions from quark-quark (antiquark) rescattering also exhibit the Landau-Pomeranchuk-Midgal (LPM) interference feature similar to gluon bremsstrahlung induced by multiple parton scattering. Compared to quark-gluon scattering, the modification, which is dominated by  $t$ -channel quark-quark (antiquark) scattering, is only smaller by a factor of  $C_F/C_A = 4/9$  times the ratio of quark and gluon distributions in the medium. Such a modification is not negligible for realistic kinematics and finite medium size. The modifications to quark (antiquark) fragmentation functions from quark-antiquark annihilation processes are shown to be determined by the antiquark (quark) distribution density in the medium. The asymmetry in quark and antiquark distributions in nuclei will lead to different modifications of quark and antiquark fragmentation functions inside a nucleus, which qualitatively explains the experimentally observed flavor dependence of the leading hadron suppression in semi-inclusive DIS off nuclear targets. The quark-antiquark annihilation processes also mix quark and gluon fragmentation functions in the large fractional momentum region, leading to a flavor dependence of jet quenching in heavy-ion collisions.

*Key words:* Jet quenching, modified fragmentation, parton energy loss.

*PACS:* 24.85.+p, 12.38.Bx, 13.87.Ce, 13.60.-r

---

## 1 Introduction

Multiple parton scattering in a dense medium can be used as a useful tool to study properties of both hot and cold nuclear matter. The success of such an approach has been demonstrated by the discovery of strong jet quenching phenomena in central  $Au + Au$  collisions at the Relativistic Heavy-ion Collider (RHIC) [1,2,3] and their implications on the formation of a strongly coupled quark-gluon plasma at RHIC [4,5]. However, for a convincing phenomenological study of the existing and future experimental data, a unified description of all medium effects in hard processes involving nuclei, such as electron-nucleus ( $e + A$ ), hadron-nucleus ( $h + A$ ) and nucleus-nucleus collisions ( $A + A$ ) has to be developed [6,7]. This must include the physics of transverse momentum broadening [8], strong nuclear enhancement in DIS [9] and Drell-Yan production [10,11], nuclear shadowing [12], and parton energy loss due to gluon radiation induced by multiple scattering [13,14,15,16,17,18,19].

There exist many different frameworks in the literature to describe multiple scattering in a nuclear medium [20,21,22]. Among them the twist expansion approach is based on the generalized factorization in perturbative QCD as initially developed by Luo, Qiu and Sterman (LQS) [23]. In the LQS formalism, multiple scattering processes generally involve high-twist multiple-parton correlations in analogy to the parton distribution operators in leading twist processes. Though the corresponding higher twist corrections are suppressed by powers of  $1/Q^2$ , they are enhanced at least by a factor of  $A^{1/3}$  due to multiple scattering in a large nucleus. This framework has been applied recently to study medium modification of the fragmentation functions as the leading parton propagates through the medium [18,19]. Because of the non-Abelian Landau-Pomeranchuk-Midgal interference in the gluon bremsstrahlung induced by multiple parton scattering in nuclei, the higher-twist nuclear modifications to the fragmentation functions are in fact enhanced by  $A^{2/3}$ , quadratic in the nuclear size [18,19]. Phenomenological study of parton energy loss and nuclear modification of the fragmentation functions in cold nuclear matter [24] gives a good description of the nuclear modification of the leading hadron spectra in semi-inclusive deeply inelastic lepton-nucleus scattering observed by the HERMES experiment [25,26]. The same framework also gives a compelling explanation for the suppression of large transverse momentum hadrons discovered at RHIC [27].

The emphasis of recent studies of medium modification of fragmentation functions has been on radiative parton energy loss induced by multiple scattering with gluons. Such processes indeed are dominant relative to multiple scattering with quarks because of the abundance of soft gluons in either cold nuclei or hot dense matter produced in heavy-ion collisions. Since gluon bremsstrahlung induced by scattering with medium gluons is the same for quarks and anti-quarks, one also expects the energy loss and fragmentation modification to be identical for quarks and anti-quarks. However, in a medium with finite baryon density such as cold nuclei and the forward region of heavy-ion collisions, the difference between quark and anti-quark distributions in the medium should lead to different energy loss and modified fragmentation functions for quarks and antiquarks through

quark-antiquark annihilation processes. To study such an asymmetry, one must consider systematically all possible quark-quark and quark-antiquark scattering processes, which will be the focus of this paper.

In this study we will calculate the modifications of quark and antiquark fragmentation functions (FF) due to quark-quark (antiquark) double scattering in a nuclear medium, working within the LQS framework for generalized factorization in perturbative QCD. For a complete description of nuclear modification of the single inclusive hadron spectra, one still have to consider medium modification of gluon fragmentation functions in addition to modified quark fragmentation function due to quark-gluon scattering [18]. The theoretical results presented in this paper will be a second step toward a complete description of medium modified fragmentation functions. However, one can already find that quark-quark (antiquark) double scattering will give different corrections to quark and antiquark FF, depending on antiquark and quark density of the medium, respectively. This difference between modified quark and antiquark FF may shed light on the interesting observation by the HERMES experiment [25,26] of a large difference between nuclear suppression of the leading proton and antiproton spectra in semi-inclusive DIS off large nuclei. Such a picture of quark-quark (antiquark) scattering can provide a competing mechanism for the experimentally observed phenomenon in addition to possible absorption of final state hadrons inside nuclear matter [28,29].

The paper is organized as follows. In the next section we will present the general formalism of our calculation including the generalized factorization of twist-4 processes. In Section III we will illustrate the procedure of calculating the hard partonic parts of quark-quark double scattering in nuclei. In Section IV we will discuss the modifications to quark and antiquark fragmentation functions due to quark-quark (antiquark) double scattering in nuclei. In Section V, we will focus on the flavor dependent part of the medium modification to the quark FF's due to quark-antiquark annihilation and we will discuss the implications for the flavor dependence of the leading hadron spectra in both DIS off a nucleus and heavy-ion collisions. We will summarize our work in Section VI. In the Appendix A-1, we collect the complete results for the hard partonic parts for different cut diagrams of quark-quark (antiquark) double rescattering in nuclei. We also provide an alternative calculation of the hard parts of the central-cut diagrams in Appendix A-3 through elastic quark-quark scattering or quark-antiquark annihilation as a cross check.

## 2 General formalism

In order to study quark and antiquark FF's in semi-inclusive deeply inelastic lepton-nucleus scattering, we consider the following processes,

$$e(L_1) + A(p) \longrightarrow e(L_2) + h(\ell_h) + X ,$$

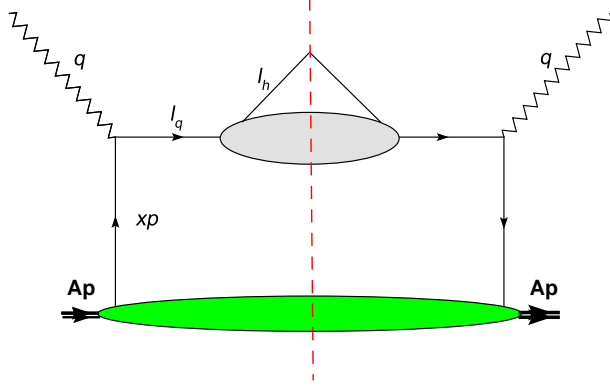

Fig. 1. Lowest order and leading-twist contribution to semi-inclusive DIS.

where  $L_1$  and  $L_2$  are the four momenta of the incoming and outgoing leptons, and  $\ell_h$  is the observed hadron momentum. The differential cross section for the semi-inclusive process can be expressed as

$$E_{L_2} E_{\ell_h} \frac{d\sigma_{\text{DIS}}^h}{d^3 L_2 d^3 \ell_h} = \frac{\alpha_{\text{EM}}^2}{2\pi s} \frac{1}{Q^4} L_{\mu\nu} E_{\ell_h} \frac{dW^{\mu\nu}}{d^3 \ell_h}, \quad (1)$$

where  $p = [p^+, 0, \mathbf{0}_\perp]$  is the momentum per nucleon in the nucleus,  $q = L_2 - L_1 = [-Q^2/2q^-, q^-, \mathbf{0}_\perp]$  the momentum transfer carried by the virtual photon,  $s = (p + L_1)^2$  the lepton-nucleon center-of-mass energy and  $\alpha_{\text{EM}}$  is the electromagnetic (EM) coupling constant. The leptonic tensor is given by  $L_{\mu\nu} = 1/2 \text{Tr}(\gamma \cdot L_1 \gamma_\mu \gamma \cdot L_2 \gamma_\nu)$  while the semi-inclusive hadronic tensor is defined as,

$$E_{\ell_h} \frac{dW_{\mu\nu}}{d^3 \ell_h} = \frac{1}{2} \sum_X \langle A | J_\mu(0) | X, h \rangle \langle X, h | J_\nu(0) | A \rangle 2\pi \delta^4(q + p - p_X - \ell_h) \quad (2)$$

where  $\sum_X$  runs over all possible final states and  $J_\mu = \sum_q e_q \bar{\psi}_q \gamma_\mu \psi_q$  is the hadronic EM current.

Assuming collinear factorization in the parton model, the leading-twist contribution to the semi-inclusive cross section can be factorized into a product of parton distributions, parton fragmentation functions and the partonic cross section. Including all leading log radiative corrections, the lowest order contribution  $[\mathcal{O}(\alpha_s^0)]$  from a single hard  $\gamma^* + q$  scattering, as illustrated in Fig. 1, can be written as

$$\frac{dW_{\mu\nu}^S}{dz_h} = \sum_q \int dx f_q^A(x, \mu_I^2) H_{\mu\nu}^{(0)}(x, p, q) D_{q \rightarrow h}(z_h, \mu^2); \quad (3)$$

$$H_{\mu\nu}^{(0)}(x, p, q) = \frac{e_q^2}{2} \text{Tr}(\gamma \cdot p \gamma_\mu \gamma \cdot (q + xp) \gamma_\nu) \frac{2\pi}{2p \cdot q} \delta(x - x_B), \quad (4)$$

where the momentum fraction carried by the hadron is defined as  $z_h = \ell_h^-/q^-$ ,  $x_B = Q^2/2p^+q^-$  is the Bjorken scaling variable,  $\mu_I^2$  and  $\mu^2$  are the factorization scales for the initial quark distributions  $f_q^A(x, \mu_I^2)$  in a nucleus and the fragmentation functions in vacuum  $D_{q \rightarrow h}(z_h, \mu^2)$ , respectively. The renormalized quark fragmentation function  $D_{q \rightarrow h}(z_h, \mu^2)$  satisfies the DGLAP QCD evolution equations [30]:

$$\frac{\partial D_{q \rightarrow h}(z_h, \mu^2)}{\partial \ln \mu^2} = \frac{\alpha_s(\mu^2)}{2\pi} \int_{z_h}^1 \frac{dz}{z} \left[ \gamma_{q \rightarrow qg}(z) D_{q \rightarrow h}(z_h/z, \mu^2) + \gamma_{q \rightarrow gq}(z) D_{g \rightarrow h}(z_h/z, \mu^2) \right]; \quad (5)$$

$$\frac{\partial D_{g \rightarrow h}(z_h, \mu^2)}{\partial \ln \mu^2} = \frac{\alpha_s(\mu^2)}{2\pi} \int_{z_h}^1 \frac{dz}{z} \left[ \sum_{q=1}^{2n_f} \gamma_{g \rightarrow q\bar{q}}(z) D_{q \rightarrow h}(z_h/z, \mu^2) + \gamma_{g \rightarrow gg}(z) D_{g \rightarrow h}(z_h/z, \mu^2) \right], \quad (6)$$

where  $\gamma_{a \rightarrow bc}(z)$  denotes the splitting functions of the corresponding radiative processes [31,32].

In DIS off a nuclear target, the propagating quark will experience additional scatterings with other partons from the nucleus. The rescatterings may induce additional parton (quark or gluon) radiation and cause the leading quark to lose energy. Such induced radiation will effectively give rise to additional terms in the DGLAP evolution equation leading to a modification of the fragmentation functions in a medium. These are power-suppressed higher-twist corrections and they involve higher-twist parton matrix elements. We will only consider those contributions that involve two-parton correlations from two different nucleons inside the nucleus. They are proportional to the thickness of the nucleus [18,23,33] and thus are enhanced by a nuclear factor  $A^{1/3}$  as compared to two-parton correlations in a nucleon. As in previous studies [18,19], we will limit our study to such double scattering processes in a nuclear medium. These are twist-four processes and give leading contributions to the nuclear effects. The contributions of higher twist processes or contributions not enhanced by the nuclear medium will be neglected for the time being.

When considering double scattering with nuclear enhancement, a very important process is quark-gluon double scattering as illustrated in Fig. 2. Such processes give the dominant contribution to the leading quark energy loss and have been studied in detailed in Refs. [18,19]. The modification to the vacuum quark fragmentation function from quark-gluon scattering is,

$$\Delta D_{q \rightarrow h}^{qg \rightarrow qg}(z_h) = \frac{\alpha_s^2 C_A}{N_c} \int \frac{d\ell_T^2}{\ell_T^4} \int_{z_h}^1 \frac{dz}{z} \left\{ D_{q \rightarrow h}(z_h/z) \left[ \frac{1+z^2}{(1-z)_+} \frac{T_{qg}^A(x, x_L)}{f_q^A(x)} + \delta(z-1) \frac{\Delta T_{qg}^A(x, \ell_T^2)}{f_q^A(x)} \right] + D_{g \rightarrow h}(z_h/z) \left[ \frac{1+(1-z)^2}{z} \frac{T_{qg}^A(x, x_L)}{f_q^A(x)} \right] \right\}, \quad (7)$$

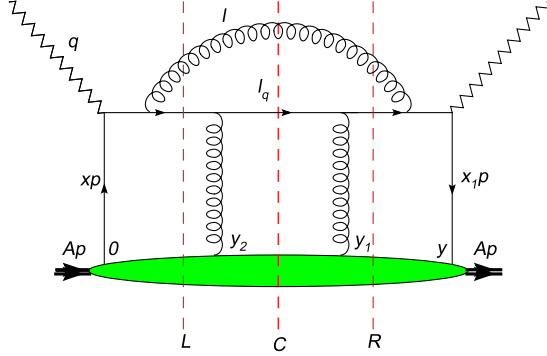

Fig. 2. A typical diagram for quark-gluon double scattering with three possible cuts [central(C), left(L) and right(R)].

where the  $+$ -function is defined as

$$\int_0^1 dz \frac{F(z)}{(1-z)_+} \equiv \int_0^1 dz \frac{F(z) - F(1)}{1-z} \quad (8)$$

for any  $F(z)$  that is sufficiently smooth at  $z = 1$  and the twist-four quark-gluon correlation function,

$$T_{qg}^A(x, x_L) = \int \frac{dy^-}{2\pi} dy_1^- dy_2^- e^{i(x+x_L)p^+ y^-} (1 - e^{-ix_L p^+ y_2^-}) (1 - e^{-ix_L p^+ (y^- - y_1^-)}) \\ \times \langle A | \bar{\psi}_q(0) \frac{\gamma^+}{2} F_{\sigma^+}(y_2^-) F^{+\sigma}(y_1^-) \psi_q(y^-) | A \rangle \theta(-y_2^-) \theta(y^- - y_1^-), \quad (9)$$

has explicit interference included. The matrix element in the virtual correction [the term with  $\delta(z - 1)$ ] is defined as

$$\Delta T_{qg}^A(x, \ell_T^2) \equiv \int_0^1 dz \frac{1}{1-z} \left[ 2T_{qg}^A(x, x_L)|_{z=1} - (1+z^2)T_{qg}^A(x, x_L) \right]. \quad (10)$$

Since  $T_{qg}^A(x, x_L)/f_q^A(x)$  is proportional to gluon distribution and independent of the flavor of the leading quark, the suppression of the hadron spectrum caused by quark-gluon or antiquark-gluon scattering should be proportional to the gluon density of the medium and is identical for quark and antiquark fragmentation. It was shown in Ref. [24] that such modification of parton fragmentation functions by quark-gluon double scattering and gluon bremsstrahlung in a nuclear medium describes very well the recent HERMES data [25] on semi-inclusive DIS off nuclear targets.

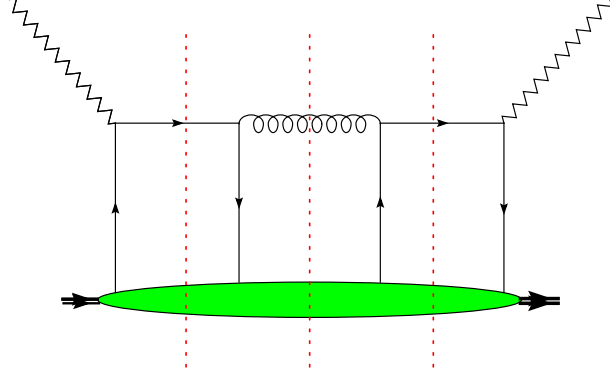

Fig. 3. Diagram for leading order quark-antiquark annihilation with three possible cuts [central(C), left(L) and right(R)].

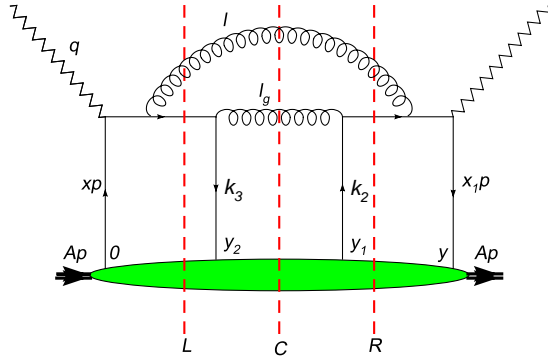

Fig. 4. A typical diagram for next-to-leading order correction to quark-antiquark annihilation with three possible cuts [central(C), left(L) and right(R)].

In this paper, we will consider quark-quark (antiquark) double scattering such as the process shown in Fig. 3 and its radiative corrections at order  $\mathcal{O}(\alpha_s^2)$  in Fig. 4. The contributions of quark-quark double scattering is proportional to the quark density in a nucleon, while the contribution of quark-gluon double scattering is proportional to the gluon density in a nucleon; and the gluon density is generally larger than the quark density in a nucleon at small momentum fraction. However, as pointed out in earlier works [18], quark-quark double scattering mixes quark and gluon fragmentation functions and therefore gives rise to new nuclear effects. The annihilation processes as shown in Figs. 3 and 4 will lead to different modifications of quark and antiquark fragmentation functions in a medium with finite baryon density (or valence quarks). Such differences will in turn lead to flavor dependence of the nuclear modification of leading hadron spectra as observed in HERMES experiment [25,26].

Quark-quark double scattering as well as quark-gluon double scattering are twist-4 processes. We will apply the same generalized factorization procedure for twist-4 processes

as developed by LQS [23] for semi-inclusive processes in DIS. In general, the twist-four contributions can be expressed as the convolution of partonic hard parts and two-parton correlation matrix elements. In this framework, contributions from double quark-quark scattering in any order of  $\alpha_s$ , *e.g.*, the quark-antiquark annihilation process as illustrated in Fig. 4, can be written in the following form,

$$\begin{aligned} \frac{dW_{\mu\nu}^D}{dz_h} = \sum_q \int \frac{p^+ dy^-}{2\pi} dy_1^- dy_2^- \overline{H}_{\mu\nu}^D(y^-, y_1^-, y_2^-, p, q, z_h) \\ \times \langle A | \bar{\psi}_q(0) \frac{\gamma^+}{2} \psi_q(y^-) \bar{\psi}_q(y_1^-) \frac{\gamma^+}{2} \psi_q(y_2^-) | A \rangle. \end{aligned} \quad (11)$$

Here we have neglected transverse momenta of all quarks in the hard partonic part. Transverse momentum dependent contributions are higher twist and are suppressed by  $\langle k_{\perp}^2 \rangle / Q^2$ . Therefore, all quarks' momenta are assumed collinear,  $k_2 = x_2 p$  and  $k_3 = x_3 p$ .  $\overline{H}_{\mu\nu}^D(y^-, y_1^-, y_2^-, p, q, z_h)$  is the Fourier transform of the partonic hard part  $\widetilde{H}_{\mu\nu}^D(x, x_1, x_2, p, q, z_h)$  in momentum space,

$$\begin{aligned} \overline{H}_{\mu\nu}^D(y^-, y_1^-, y_2^-, p, q, z_h) &= \int dx \frac{dx_1}{2\pi} \frac{dx_2}{2\pi} e^{ix_1 p^+ y^- + ix_2 p^+ y_1^- + i(x-x_1-x_2)p^+ y_2^-} \\ &\quad \times \widetilde{H}_{\mu\nu}^D(x, x_1, x_2, p, q, z_h) \\ &= \int dx H_{\mu\nu}^{(0)}(x, p, q) \overline{H}^D(y^-, y_1^-, y_2^-, x, p, q, z_h), \end{aligned} \quad (12)$$

where, in collinear approximation, the hard partonic part  $H_{\mu\nu}^{(0)}(x, p, q)$  [Eq. (4)] in the leading twist without multiple parton scattering can be factorized out of the high-twist hard part  $\widetilde{H}_{\mu\nu}^D(x, x_1, x_2, p, q, z_h)$ . The momentum fractions  $x, x_1$ , and  $x_2$  are fixed by  $\delta$ -functions of the on-shell conditions of the final state partons and poles of parton propagators in the partonic hard part. The phase factors in  $\overline{H}_{\mu\nu}^D(y^-, y_1^-, y_2^-, p, q, z_h)$  can then be factored out, which in turn will be combined with the partonic fields in Eq. (11) to give twist-four partonic matrix elements or two-parton correlations. The quark-quark double scattering corrections in Eq. (11) can then be factorized as the convolution of fragmentation functions, twist-four partonic matrix elements and the partonic hard scattering cross sections. For scatterings (versus the annihilation) with quarks (antiquarks), a summation over the flavor of the secondary quarks (antiquarks) should be included in two-quark correlation matrix elements and both  $t, u$  channels and their interferences should be considered for scattering of identical quarks in the hard partonic parts.

After factorization, we then define the twist-four correction to the leading twist quark fragmentation function in the same form [Eq. (3)],

$$\frac{dW_{\mu\nu}^D}{dz_h} \equiv \sum_q \int dx f_q^A(x) H_{\mu\nu}^{(0)}(x, p, q) \Delta D_{q \rightarrow h}(z_h). \quad (13)$$



### 3 Quark-quark double scattering processes

In this section we will discuss the calculation of the hard part of quark-quark double scattering in detail. The lowest order process of quark-quark (antiquark) double scattering in nuclei is quark-antiquark annihilation (or quark-gluon conversion) as shown in Fig. 3. The hard partonic parts from the three cut diagrams in this figure are [18]:

$$\begin{aligned} \overline{H}_{0,C}^D(y^-, y_1^-, y_2^-, x, p, q, z_h) &= D_{g \rightarrow h}(z_h) \frac{2\pi\alpha_s}{N_c} 2C_F \frac{x_B}{Q^2} e^{ixp^+y^-} \\ &\quad \times \theta(-y_2^-) \theta(y^- - y_1^-), \end{aligned} \quad (14)$$

$$\begin{aligned} \overline{H}_{0,L}^D(y^-, y_1^-, y_2^-, x, p, q, z_h) &= D_{q \rightarrow h}(z_h) \frac{2\pi\alpha_s}{N_c} 2C_F \frac{x_B}{Q^2} e^{ixp^+y^-} \\ &\quad \times \theta(y_1^- - y_2^-) \theta(y^- - y_1^-), \end{aligned} \quad (15)$$

$$\begin{aligned} \overline{H}_{0,R}^D(y^-, y_1^-, y_2^-, x, p, q, z_h) &= D_{q \rightarrow h}(z_h) \frac{2\pi\alpha_s}{N_c} 2C_F \frac{x_B}{Q^2} e^{ixp^+y^-} \\ &\quad \times \theta(-y_2^-) \theta(y_2^- - y_1^-). \end{aligned} \quad (16)$$

The main focus of this paper is about contributions from the next-leading order corrections to the above lowest order process. There is a total of 12 diagrams for real corrections at one-loop level as illustrated in Fig. 5 to Fig. 16 in the Appendix A-1, each having up to three different cuts. In this section, we demonstrate the calculation of the hard parts from the quark-antiquark annihilation in Fig. 4 in detail as an example. We will list the complete results of all diagrams in Appendix A.

One can write down the hard partonic part of the central-cut diagram of Fig. 4 (Fig. 5 in Appendix A-1) according to the conventional Feynman rule,

$$\begin{aligned} \overline{H}_{C\mu\nu}^D(y^-, y_1^-, y_2^-, p, q, z_h) &= \int_{z_h}^1 \frac{dz}{z} D_{g \rightarrow h}\left(\frac{z_h}{z}\right) \int dx \frac{dx_1}{2\pi} \frac{dx_2}{2\pi} e^{ix_1p^+y^- + ix_2p^+y_1^-} \\ &\quad \times e^{i(x-x_1-x_2)p^+y_2^-} \int \frac{d^4\ell}{(2\pi)^4} \text{Tr} \left[ \frac{\not{p}}{2} \gamma_\mu \widehat{H} \gamma_\nu \right] 2\pi\delta_+(\ell^2) 2\pi\delta_+(\ell_g^2) \delta\left(1 - z - \frac{\ell^-}{q^-}\right), \\ \widehat{H} &= \frac{C_F^2}{N_c} g^4 \frac{\gamma \cdot (q + x_1p)}{(q + x_1p)^2 - i\epsilon} \gamma_\alpha \frac{\gamma \cdot (q + x_1p - \ell)}{(q + x_1p - \ell)^2 - i\epsilon} \gamma_\beta \frac{\not{p}}{2} \gamma_\sigma \\ &\quad \times \frac{\gamma \cdot (q + xp - \ell)}{(q + xp - \ell)^2 + i\epsilon} \gamma_\rho \frac{\gamma \cdot (q + xp)}{(q + xp)^2 + i\epsilon} \varepsilon^{\alpha\rho}(\ell) \varepsilon^{\beta\sigma}(\ell_g), \end{aligned} \quad (17)$$

where  $\delta_+$  is a Dirac *delta*-function with only the positive solution in its functional variable,  $\varepsilon^{\alpha\rho}(\ell) = -g^{\alpha\rho} + (n^\alpha\ell^\rho + n^\rho\ell^\alpha)/n \cdot \ell$  is the polarization tensor of a gluon propagator in an axial gauge ( $n \cdot A = 0$ ) with  $n = [1, 0^-, \vec{0}_\perp]$ ,  $\ell$  and  $\ell_g = q + (x_1 + x_2)p - \ell$  are the 4-momenta carried by the two final gluons respectively. The fragmenting gluon carries

a fraction,  $z = \ell_g^-/q^-$ , of the initial quark's longitudinal momentum (the large minus component).

To simplify the calculation in the case of small transverse momentum  $\ell_T \ll q^-, p^+$ , we can apply the collinear approximation to complete the trace of the product of  $\gamma$ -matrices,

$$\widehat{H} \approx \gamma \cdot \ell_q \frac{1}{4\ell_g^-} \text{Tr} [\gamma \cdot \ell_q \widehat{H}]. \quad (18)$$

According to the convention in Eqs. (11) and (12), contributions from quark-quark double scattering in the nuclear medium to the semi-inclusive hadronic tensor in DIS off a nucleus can be expressed in the general factorized form:

$$\begin{aligned} \frac{dW_{q\bar{q},\mu\nu}^D}{dz_h} &= \sum_q \int dx H_{\mu\nu}^{(0)}(x, p, q) \int \frac{p^+ dy^-}{2\pi} dy_1^- dy_2^- \overline{H}^D(y^-, y_1^-, y_2^-, x, p, q, z_h) \\ &\times \langle A | \bar{\psi}_q(0) \frac{\gamma^+}{2} \psi_{\bar{q}}(y^-) \bar{\psi}_q(y_1^-) \frac{\gamma^+}{2} \psi_{\bar{q}}(y_2^-) | A \rangle. \end{aligned} \quad (19)$$

After carrying out the momentum integration in  $x$ ,  $x_1$ ,  $x_2$  and  $\ell^\pm$  in Eq. (17) with the help of contour integration and  $\delta$ -functions, one obtains the hard partonic part,  $\overline{H}^D$ , of the rescattering for the central-cut diagram in Fig. 4 (Fig. 5) as

$$\begin{aligned} \overline{H}_{5,C}^D(y^-, y_1^-, y_2^-, x, p, q, z_h) &= \frac{\alpha_s^2 x_B}{Q^2} \int \frac{d\ell_T^2}{\ell_T^2} \int_{z_h}^1 \frac{dz}{z} D_{g \rightarrow h}(z_h/z) \frac{C_F^2}{N_c} \\ &\times \frac{2(1+z^2)}{z(1-z)} \overline{I}_{5,C}(y^-, y_1^-, y_2^-, x, x_L, p), \end{aligned} \quad (20)$$

$$\begin{aligned} \overline{I}_{5,C}(y^-, y_1^-, y_2^-, x, x_L, p) &= e^{i(x+x_L)p^+y^-} \theta(-y_2^-) \theta(y^- - y_1^-) \\ &\times (1 - e^{-ix_L p^+ y_2^-}) (1 - e^{-ix_L p^+(y^- - y_1^-)}), \end{aligned} \quad (21)$$

where the momentum fractions  $x_L$  is defined as

$$x_L = \frac{\ell_T^2}{2p^+ q^- z(1-z)}. \quad (22)$$

Note that the function  $\overline{I}_{5,C}(y^-, y_1^-, y_2^-, x, x_L, p)$  contains only phase factors. One can combine these phase factors with the matrix elements of the quark fields to define a special two-quark correlation function

$$\begin{aligned} T_{q\bar{q}}^{A(5,C)}(x, x_L) &= \int \frac{p^+ dy^-}{2\pi} dy_1^- dy_2^- \langle A | \bar{\psi}_q(0) \frac{\gamma^+}{2} \psi_{\bar{q}}(y^-) \bar{\psi}_q(y_1^-) \frac{\gamma^+}{2} \psi_{\bar{q}}(y_2^-) | A \rangle \\ &\times \overline{I}_{5,C}(y^-, y_1^-, y_2^-, x, x_L, p). \end{aligned} \quad (23)$$

The contribution from quark-antiquark annihilation in the central-cut diagram in Fig. 4 to the hadronic tensor can then be expressed as

$$\begin{aligned} \frac{dW_{q\bar{q},\mu\nu}^D}{dz_h} = \sum_q \int dx H_{\mu\nu}^{(0)}(x, p, q) \frac{\alpha_s^2 x_B}{Q^2} \int \frac{d\ell_T^2}{\ell_T^2} \int_{z_h}^1 \frac{dz}{z} D_{g \rightarrow h}\left(\frac{z_h}{z}\right) \\ \times \frac{C_F^2}{N_c} \frac{2(1+z^2)}{z(1-z)} T_{q\bar{q}}^{A(5,C)}(x, x_L). \end{aligned} \quad (24)$$

Contributions from all quark-quark (antiquark) double scattering processes can be cast in the above factorized form.

The structure of the phase factors in  $\bar{T}_{5,C}(y^-, y_1^-, y_2^-, x, x_L, p)$  is exactly the same as for gluon bremsstrahlung induced by quark-gluon scattering as studied in Ref. [18,19]. It resembles the cross section of dipole scattering and represents contributions from two different processes and their interferences. It contains essentially four terms,

$$\begin{aligned} \bar{T}_{5,C}(y^-, y_1^-, y_2^-, x, x_L, p) = \theta(-y_2^-) \theta(y^- - y_1^-) e^{i(x+x_L)p^+ y^-} \\ \times [1 + e^{-ix_L p^+(y^- + y_2^- - y_1^-)} - e^{-ix_L p^+ y_2^-} - e^{-ix_L p^+(y^- - y_1^-)}]. \end{aligned} \quad (25)$$

The first term corresponds to the so-called hard-soft processes where the gluon emission is induced by the hard scattering between the virtual photon  $\gamma^*$  and the initial quark with momentum  $(x+x_L)p$ . The quark then becomes on-shell before it annihilates with a soft antiquark from the nucleus that carries zero momentum and converts into a real gluon in the final state. The second term corresponds to a process in which the initial quark with momentum  $xp$  is on-shell after the first hard  $\gamma^*$ -quark scattering. It then annihilates with another antiquark and produces two final gluons in the final state. In this process, the antiquark carries finite (hard) momentum  $x_L p$ . Therefore one often refers to this process as double-hard scattering as compared to the first process in which the antiquark carries zero momentum. Set aside the change of flavors in the initial and final states, the double-hard scattering corresponds essentially to two-parton elastic scattering with finite momentum and energy transfer. This is in contrast to the hard-soft scattering which is essentially the final state radiation of the  $\gamma^*$ -quark scattering and the total energy and momentum of the two final state gluons all come from the initial quark. The corresponding matrix elements of the two-quark correlation functions from these first two terms are called ‘diagonal’ elements.

The third and fourth terms with negative signs in  $\bar{T}_{5,C}(y^-, y_1^-, y_2^-, x, x_L, p)$  are interferences between hard-soft and double hard processes. The corresponding matrix elements are called ‘off-diagonal’. The cancellation between the two diagonal and off-diagonal terms essentially gives rise to the destructive interference which is very similar to the Landau-Pomeranchuk-Migdal (LPM) interference in gluon bremsstrahlung induced by quark-gluon double scattering [18,19]. One can similarly define the formation time of the

parton (quark or gluon) emission as

$$\tau_f \equiv \frac{1}{x_L p^+} . \quad (26)$$

In the limit of collinear emission ( $x_L \rightarrow 0$ ) or when the formation time of the parton emission,  $\tau_f$ , is much larger than the nuclear size, the effective matrix element vanishes because

$$\bar{I}_{5,C}(y^-, y_1^-, y_2^-, x, x_L, p)|_{x_L=0} \rightarrow 0 , \quad (27)$$

when the hard-soft and double hard processes have complete destructive interference.

We should note that in the central-cut diagram of Fig. 4, the final state partons are two gluons. Therefore, in Eq. (20) the gluon fragmentation function in vacuum  $D_{g \rightarrow h}(z_h/z)$  enters. If the other gluon (close to the  $\gamma^*$ -quark interaction) fragments, the contribution to the semi-inclusive hadronic tensor is similar except that the corresponding effective ‘‘splitting function’’ should be replaced by

$$\frac{1+z^2}{z(1-z)} \rightarrow \frac{1+(1-z)^2}{z(1-z)} . \quad (28)$$

As we will show in Appendix A-1, the two gluons in the quark-antiquark annihilation processes (central-cut diagrams) are symmetric when contributions from all possible annihilation processes and their interferences are summed. Therefore, one can simply multiply the final results by a factor of 2 to take into account the hadronization of the second final-state gluon.

In addition to the central-cut diagram, one should also take into account the asymmetrical-cut diagrams in Fig. 4, which represent interference between gluon emission from single and triple scattering. The hard partonic parts are mainly the same as for the central-cut diagram. The only differences are in the phase factors and the fragmentation functions since the fragmenting parton can be the final-state quark or gluon. These hard parts can be calculated following a similar procedure and one gets,

$$\begin{aligned} \bar{H}_{5,L(R)}^D(y^-, y_1^-, y_2^-, x, p, q, z_h) &= \frac{\alpha_s^2 x_B}{Q^2} \int \frac{d\ell_T^2}{\ell_T^2} \int \frac{dz}{z} D_{q \rightarrow h}\left(\frac{z_h}{z}\right) \frac{C_F^2}{N_c} \frac{2(1+z^2)}{z(1-z)} \\ &\quad \times \bar{I}_{5,L(R)}(y^-, y_1^-, y_2^-, x, x_L, p) , \end{aligned} \quad (29)$$

$$\begin{aligned} \bar{I}_{5,L}(y^-, y_1^-, y_2^-, x, x_L, p) &= -e^{i(x+x_L)p^+ y^-} (1 - e^{-ix_L p^+(y^- - y_1^-)}) \\ &\quad \times \theta(y_1^- - y_2^-) \theta(y^- - y_1^-) , \end{aligned} \quad (30)$$

$$\begin{aligned} \bar{I}_{5,R}(y^-, y_1^-, y_2^-, x, x_L, p) &= -e^{i(x+x_L)p^+ y^-} (1 - e^{-ix_L p^+ y_2^-}) \\ &\quad \times \theta(-y_2^-) \theta(y_2^- - y_1^-) . \end{aligned} \quad (31)$$

In the asymmetrical cut diagrams, the above contributions come from the fragmentation of the final-state quark. Therefore, quark fragmentation function  $D_{q \rightarrow h}(z_h/z)$  enters this contribution. For gluon fragmentation into the observed hadron in this asymmetrical-cut diagrams, the contribution can be obtained by simply replacing the quark fragmentation function by the gluon fragmentation function  $D_{g \rightarrow h}(z_h/z)$  and replacing  $z$  by  $1 - z$ . Summing the contributions from three different cut diagrams of Fig. 4, we can observe further examples of mixing (or conversion) of quark and gluon fragmentation functions. This medium-induced mixing was first observed by Wang and Guo [18] and is a unique feature of quark-quark (antiquark) double scattering among all multiple parton scattering processes.

With the same procedure we can calculate contributions from all other cut diagrams of quark-quark (antiquark) double scattering at order  $\mathcal{O}(\alpha_s^2)$ , which are listed in Appendix A-1. There are three types of processes: two annihilation processes,  $q\bar{q} \rightarrow gg$  (central-cut diagrams in Figs. 5, 6, 7, 8 and 9),  $q\bar{q} \rightarrow q_i\bar{q}_i$  (central-cut diagram in Fig. 10) and quark-quark (antiquark) scattering,  $qq_i(\bar{q}_i) \rightarrow qq_i(\bar{q}_i)$  (central-cut diagram in Fig. 11). One also has to consider the interference of  $s$  and  $t$ -channel amplitude for annihilation into an identical quark pair,  $q\bar{q} \rightarrow q\bar{q}$  (central-cut diagrams in Figs. 12 and 13) and the interference between  $t$  and  $u$  channels of identical quark scattering  $qq \rightarrow qq$  (central-cut diagram in Fig. 14).

Contributions from left and right-cut diagrams correspond to interference between the amplitude of gluon radiation from single  $\gamma^*$ -quark scattering and triple quark scattering. The amplitudes of gluon radiation via triple quark scattering essentially come from radiative corrections to the left and right-cut diagrams of the lowest-order quark-antiquark annihilation in Fig. 3 (as shown in left and right-cut diagrams in Figs. 5, 6, 8, 9, 12, 13, 15 and 16). Two other triple quark scatterings with gluon radiation, shown as the left and right-cut diagrams in Figs. 11 and 14, correspond to the case where one of the final state quarks, after quark-quark scattering, annihilates with another antiquark and converts into a final state gluon.

## 4 Modified Fragmentation Functions

In order to simplify the contributions from quark-quark (antiquark) scattering (annihilation), one can first organize the results of the hard parts in terms of contributions from central, left or right-cut diagrams, which are associated by contour integrals with specific products of  $\theta$ -functions,

$$\begin{aligned} \overline{H}^D = & H_C^D \theta(-y_2^-) \theta(y^- - y_1^-) - H_L^D \theta(y_1^- - y_2^-) \theta(y^- - y_1^-) \\ & - H_R^D \theta(-y_2^-) \theta(y_2^- - y_1^-). \end{aligned} \quad (32)$$

These  $\theta$ -functions provide a space-time ordering of the parton correlation and will restrict the integration range along the light-cone. For contributions from central, left and right-cut diagrams that have identical hard partonic parts,  $H_C^{D(c)} = H_L^{D(c)} = H_R^{D(c)}$ , they will have a common combination of  $\theta$ -functions that produces a path-ordered integral,

$$\int_0^{y^-} dy_1^- \int_0^{y_1^-} dy_2^- = - \int dy_1^- dy_2^- \left[ \theta(-y_2^-) \theta(y^- - y_1^-) - \theta(-y_2^-) \theta(y_2^- - y_1^-) - \theta(y^- - y_1^-) \theta(y_1^- - y_2^-) \right] \quad (33)$$

that is limited only by the spatial-spread  $y^-$  of the first parton along the light-cone coordinate. For a high-energy parton that carries momentum fraction  $xp^+$ ,  $y^- \sim 1/xp^+$  should be very small. Those contributions that are proportional to the above path-ordered integral are referred to as contact contributions (or contact interactions).

Similarly,  $y_1^- - y_2^-$  is the spatial spread of the second parton and can only be limited by the spatial size of its host nucleon even for small value of momentum fraction. The spatial position of its host nucleon,  $y_1^- + y_2^-$ , however, can be anywhere within the nucleus. Therefore, any contributions from double parton scattering that have unrestricted integration over  $y_1^-$  and  $y_2^-$  should be proportional to the nuclear size of the target  $A^{1/3}$  and therefore are nuclear enhanced. In this paper, we will only keep the nuclear enhanced contributions and neglect the contact contributions. This will greatly simplify the final results for double parton scattering.

#### 4.1 $q\bar{q} \rightarrow g$ annihilation

For the lowest order of quark-antiquark annihilation in Eqs. (14)-(16), the hard parts from the three cut diagrams are almost the same except for the parton fragmentation functions. The central-cut diagram is proportional to the gluon fragmentation function while the left and right-cut diagrams are proportional to quark fragmentation functions. Rearranging the contributions from the three cut diagrams and neglecting the contact term that is proportional to the path-ordered integral as in Eq. (33), the total contribution can be written as

$$\frac{dW_{\mu\nu}^{D(0)}}{dz_h} = \sum_q \int dx T_{q\bar{q}}^{A(H)}(x, 0) \frac{2\pi\alpha_s}{N_c} 2C_F \frac{x_B}{Q^2} H_{\mu\nu}^{(0)}(x, p, q) \times [D_{g \rightarrow h}(z_h) - D_{q \rightarrow h}(z_h)]. \quad (34)$$

According to our definition in Eq. (13) of the twist-four correction to the quark fragmentation functions, the modification to the quark fragmentation function from the lowest

order quark-antiquark annihilation is then,

$$\Delta D_{q \rightarrow h}^{(q\bar{q} \rightarrow g)}(z_h) = \frac{2\pi\alpha_s}{N_c} 2C_F \frac{x_B}{Q^2} [D_{g \rightarrow h}(z_h) - D_{q \rightarrow h}(z_h)] \frac{T_{q\bar{q}}^{A(H)}(x, 0)}{f_q^A(x)}. \quad (35)$$

Here the effective quark-antiquark correlation function  $T_{q\bar{q}}^{A(H)}(x, 0)$  is defined as,

$$\begin{aligned} T_{q\bar{q}_i}^{A(H)}(x, x_L) &\equiv \int \frac{p^+ dy^-}{2\pi} dy_1^- dy_2^- e^{ixp^+y^- - ix_L p^+(y_2^- - y_1^-)} \theta(-y_2^-) \theta(y^- - y_1^-) \\ &\times \langle A | \bar{\psi}_q(0) \frac{\gamma^+}{2} \psi_q(y^-) \bar{\psi}_{q_i}(y_1^-) \frac{\gamma^+}{2} \psi_{q_i}(y_2^-) | A \rangle, \end{aligned} \quad (36)$$

with the antiquark  $\bar{q}_i$  carrying momentum fraction  $x_L$ . This two-parton correlation function is always associated with double-hard rescattering processes. Similarly, we define three other quark-antiquark correlation matrix elements

$$\begin{aligned} T_{q\bar{q}_i}^{A(S)}(x, x_L) &\equiv \int \frac{p^+ dy^-}{2\pi} dy_1^- dy_2^- e^{i(x+x_L)p^+y^-} \theta(y^- - y_1^-) \\ &\times \theta(-y_2^-) \langle A | \bar{\psi}_q(0) \frac{\gamma^+}{2} \psi_q(y^-) \bar{\psi}_{q_i}(y_1^-) \frac{\gamma^+}{2} \psi_{q_i}(y_2^-) | A \rangle, \end{aligned} \quad (37)$$

$$\begin{aligned} T_{q\bar{q}_i}^{A(I-L)}(x, x_L) &\equiv \int \frac{p^+ dy^-}{2\pi} dy_1^- dy_2^- e^{i(x+x_L)p^+y^- - ix_L p^+(y^- - y_1^-)} \theta(y^- - y_1^-) \\ &\times \theta(-y_2^-) \langle A | \bar{\psi}_q(0) \frac{\gamma^+}{2} \psi_q(y^-) \bar{\psi}_{q_i}(y_1^-) \frac{\gamma^+}{2} \psi_{q_i}(y_2^-) | A \rangle, \end{aligned} \quad (38)$$

$$\begin{aligned} T_{q\bar{q}_i}^{A(I-R)}(x, x_L) &\equiv \int \frac{p^+ dy^-}{2\pi} dy_1^- dy_2^- e^{i(x+x_L)p^+y^- - ix_L p^+ y_2^-} \theta(y^- - y_1^-) \\ &\times \theta(-y_2^-) \langle A | \bar{\psi}_q(0) \frac{\gamma^+}{2} \psi_q(y^-) \bar{\psi}_{q_i}(y_1^-) \frac{\gamma^+}{2} \psi_{q_i}(y_2^-) | A \rangle, \end{aligned} \quad (39)$$

that are associated with hard-soft rescattering and interference between double hard and hard-soft rescattering. In the first parton correlation  $T_{q\bar{q}_i}^{A(H)}(x, x_L)$ , the antiquark  $\bar{q}_i$  carries momentum fraction  $x_L$  while the initial quark has the momentum fraction  $x$ . The two-parton correlation  $T_{q\bar{q}_i}^{A(S)}(x, x_L)$  corresponds to the case when the leading quark has  $x + x_L$  but the antiquark carries zero momentum. The two interference matrix elements are approximately the same for small value of  $x_L$  and will be denoted as  $T_{q\bar{q}_i}^{A(I)}(x, x_L)$ .

#### 4.2 $q\bar{q} \rightarrow q_i\bar{q}_i$ annihilation

Contributions from the next-to-leading order quark-antiquark annihilation or quark-quark (antiquark) scattering are more complicated since they involve many real and virtual corrections. The simplest real correction comes from  $q\bar{q} \rightarrow q_i\bar{q}_i$  annihilation ( $q_i \neq q$ ) [Fig. 10 and Eqs. (A-25) and (A-26)] which has only a central-cut diagram,

$$\begin{aligned}
\Delta D_{q \rightarrow h}^{(q\bar{q} \rightarrow q_i \bar{q}_i)}(z_h) &= \frac{C_F \alpha_s^2 x_B}{N_C Q^2} \int \frac{d\ell_T^2}{\ell_T^2} \int_{z_h}^1 \frac{dz}{z} [z^2 + (1-z)^2] \\
&\times \sum_{q_i \neq q} [D_{q_i \rightarrow h}(z_h/z) + D_{\bar{q}_i \rightarrow h}(z_h/z)] \frac{T_{q\bar{q}}^{A(H)}(x, x_L)}{f_q^A(x)}. \tag{40}
\end{aligned}$$

This kind of  $q\bar{q}$  annihilation is truly a hard processes and thus requires the second antiquark to carry finite initial momentum fraction  $x_L$ . Furthermore, there are no other interfering processes.

### 4.3 $qq_i(\bar{q}_i) \rightarrow qq_i(\bar{q}_i)$ scattering

Contributions from non-identical quark-quark scattering  $q\bar{q}_i \rightarrow q\bar{q}_i$  ( $q_i \neq q$ ) are a little complicated because they involve all three cut diagrams (central, left and right) [Eqs. (A-28)-(A-32)]. One can factor out the  $\theta$ -functions in the hard parts according to Eq. (32) and re-organize the phase factors in each cut diagram,

$$\begin{aligned}
I_{11,C} &= e^{i(x+x_L)p^+y^-} (1 - e^{-ix_Lp^+y_2^-}) (1 - e^{-ix_Lp^+(y^- - y_1^-)}) \\
&= e^{i(x+x_L)p^+y^-} [1 - e^{-ix_Lp^+y_2^-} - e^{-ix_Lp^+(y^- - y_1^-)} + e^{-ix_Lp^+(y^- + y_2^- - y_1^-)}]; \\
I_{11,L} &= e^{i(x+x_L)p^+y^-} (1 - e^{-ix_Lp^+(y^- - y_1^-)}) \\
&= e^{i(x+x_L)p^+y^-} [1 - e^{-ix_Lp^+y_2^-} - e^{-ix_Lp^+(y^- - y_1^-)} + e^{-ix_Lp^+y_2^-}]; \\
I_{11,R} &= e^{i(x+x_L)p^+y^-} (1 - e^{-ix_Lp^+y_2^-}) \\
&= e^{i(x+x_L)p^+y^-} [1 - e^{-ix_Lp^+y_2^-} - e^{-ix_Lp^+(y^- - y_1^-)} + e^{-ix_Lp^+(y^- - y_1^-)}], \tag{41}
\end{aligned}$$

such that the first three terms in each amplitude are the same. These three common phase factors will give rise to a contact contribution for all similar hard parts from the three cut diagrams, which we will neglect since they are not nuclear enhanced. The remaining part will have the following phase factors,

$$\begin{aligned}
\bar{T}_{11} &= e^{i(x+x_L)p^+y^-} [\theta(-y_2^-)\theta(y^- - y_1^-)e^{-ix_Lp^+(y^- + y_2^- - y_1^-)} \\
&- \theta(y_1^- - y_2^-)\theta(y^- - y_1^-)e^{-ix_Lp^+y_2^-} - \theta(-y_2^-)\theta(y_2^- - y_1^-)e^{-ix_Lp^+(y^- - y_1^-)}]. \tag{42}
\end{aligned}$$

Note that the phase factors of the last two terms in the above equation give identical contributions to the matrix elements when intergated over  $y_1^-$  and  $y_2^-$  as they differ only by the substitution  $y_2^- \leftrightarrow y_1^- - y^-$ . One therefore can combine them with  $\theta(-y_2^-)\theta(y^- - y_1^-)e^{-ix_Lp^+(y^- - y_1^-)}$  to form another contact contribution (path-ordered) which can be neglected. The final effective phase factor is then

$$\bar{T}_{11} = e^{ixp^+y^- - ix_Lp^+(y_2^- - y_1^-)} (1 - e^{ix_Lp^+y_2^-}). \tag{43}$$



Using the above effective phase factor, one can obtain the effective modification to the quark fragmentation function due to quark-antiquark scattering,  $q\bar{q}_i \rightarrow q\bar{q}_i$ ,

$$\begin{aligned}
\Delta D_{q \rightarrow h}^{(q\bar{q}_i \rightarrow q\bar{q}_i)}(z_h) &= \frac{C_F \alpha_s^2 x_B}{N_c Q^2} \int \frac{d\ell_T^2}{\ell_T^2} \int_{z_h}^1 \frac{dz}{z} \sum_{\bar{q}_i \neq \bar{q}} \left\{ \left[ D_{q \rightarrow h}(z_h/z) \frac{1+z^2}{(1-z)^2} \right. \right. \\
&\quad \left. \left. + D_{g \rightarrow h}(z_h/z) \frac{1+(1-z)^2}{z^2} \right] \frac{T_{q\bar{q}_i}^{A(HI)}(x, x_L)}{f_q^A(x)} \right. \\
&\quad \left. + [D_{\bar{q}_i \rightarrow h}(z_h/z) - D_{g \rightarrow h}(z_h/z)] \frac{1+(1-z)^2}{z^2} \frac{T_{q\bar{q}_i}^{A(HS)}(x, x_L)}{f_q^A(x)} \right\} \\
&= \frac{C_F \alpha_s^2 x_B}{N_c Q^2} \int \frac{d\ell_T^2}{\ell_T^2} \int_{z_h}^1 \frac{dz}{z} \sum_{\bar{q}_i \neq \bar{q}} \left\{ \left[ D_{q \rightarrow h}(z_h/z) \frac{1+z^2}{(1-z)^2} \right. \right. \\
&\quad \left. \left. + D_{\bar{q}_i \rightarrow h}(z_h/z) \frac{1+(1-z)^2}{z^2} \right] \frac{T_{q\bar{q}_i}^{A(HI)}(x, x_L)}{f_q^A(x)} \right. \\
&\quad \left. + [D_{\bar{q}_i \rightarrow h}(z_h/z) - D_{g \rightarrow h}(z_h/z)] \frac{1+(1-z)^2}{z^2} \frac{T_{q\bar{q}_i}^{A(SI)}(x, x_L)}{f_q^A(x)} \right\}, \tag{44}
\end{aligned}$$

where three types of two-parton correlations are defined:

$$\begin{aligned}
T_{q\bar{q}_i}^{A(HI)}(x, x_L) &\equiv T_{q\bar{q}_i}^{A(H)}(x, x_L) - T_{q\bar{q}_i}^{A(I)}(x, x_L) \\
&= \int \frac{p^+ dy^-}{2\pi} dy_1^- dy_2^- e^{ixp^+ y^- - ix_L p^+ (y_2^- - y_1^-)} (1 - e^{ix_L p^+ y_2^-}) \\
&\quad \times \langle A | \bar{\psi}_q(0) \frac{\gamma^+}{2} \psi_q(y^-) \bar{\psi}_{q_i}(y_1^-) \frac{\gamma^+}{2} \psi_{q_i}(y_2^-) | A \rangle \theta(-y_2^-) \theta(y^- - y_1^-), \tag{45}
\end{aligned}$$

$$\begin{aligned}
T_{q\bar{q}_i}^{A(SI)}(x, x_L) &\equiv T_{q\bar{q}_i}^{A(S)}(x, x_L) - T_{q\bar{q}_i}^{A(I)}(x, x_L) \\
&= \int \frac{p^+ dy^-}{2\pi} dy_1^- dy_2^- e^{i(x+x_L)p^+ y^-} (1 - e^{-ix_L p^+ y_2^-}) \\
&\quad \times \langle A | \bar{\psi}_q(0) \frac{\gamma^+}{2} \psi_q(y^-) \bar{\psi}_{q_i}(y_1^-) \frac{\gamma^+}{2} \psi_{q_i}(y_2^-) | A \rangle \theta(-y_2^-) \theta(y^- - y_1^-), \tag{46}
\end{aligned}$$

$$\begin{aligned}
T_{q\bar{q}_i}^{A(HS)}(x, x_L) &\equiv T_{q\bar{q}_i}^{A(HI)}(x, x_L) + T_{q\bar{q}_i}^{A(SI)}(x, x_L) \\
&= \int \frac{p^+ dy^-}{2\pi} dy_1^- dy_2^- e^{i(x+x_L)p^+ y^-} (1 - e^{-ix_L p^+ y_2^-}) \\
&\quad \times (1 - e^{-ix_L p^+ (y^- - y_1^-)}) \theta(-y_2^-) \theta(y^- - y_1^-) \\
&\quad \times \langle A | \bar{\psi}_q(0) \frac{\gamma^+}{2} \psi_q(y^-) \bar{\psi}_{q_i}(y_1^-) \frac{\gamma^+}{2} \psi_{q_i}(y_2^-) | A \rangle. \tag{47}
\end{aligned}$$

One can similarly obtain the modification of quark fragmentation from non-identical quark-quark scattering by replacing  $\bar{q}_i \rightarrow q_i$  in Eq. (44),

$$\begin{aligned}
\Delta D_{q \rightarrow h}^{(qq_i \rightarrow qq_i)}(z_h) &= \frac{C_F \alpha_s^2 x_B}{N_c Q^2} \int \frac{d\ell_T^2}{\ell_T^2} \int_{z_h}^1 \frac{dz}{z} \sum_{q_i \neq q} \left\{ \left[ D_{q \rightarrow h}(z_h/z) \frac{1+z^2}{(1-z)^2} \right. \right. \\
&\quad \left. \left. + D_{q_i \rightarrow h}(z_h/z) \frac{1+(1-z)^2}{z^2} \right] \frac{T_{qq_i}^{A(HI)}(x, x_L)}{f_q^A(x)} \right. \\
&\quad \left. + [D_{q_i \rightarrow h}(z_h/z) - D_{g \rightarrow h}(z_h/z)] \frac{1+(1-z)^2}{z^2} \frac{T_{qq_i}^{A(SI)}(x, x_L)}{f_q^A(x)} \right\}. \tag{48}
\end{aligned}$$

The two-quark correlations,  $T_{qq_i}^{A(HI)}(x, x_L)$  and  $T_{qq_i}^{A(SI)}(x, x_L)$  can be obtained from  $T_{q\bar{q}_i}^{A(HI)}(x, x_L)$  and  $T_{q\bar{q}_i}^{A(SI)}(x, x_L)$ , respectively, by making the replacements  $\psi_{q_i}(y_2) \rightarrow \bar{\psi}_{q_i}(y_2)$  and  $\bar{\psi}_{q_i}(y_1) \rightarrow \psi_{q_i}(y_1)$  in Eqs. (45) and (46),

$$\begin{aligned}
T_{qq_i}^{A(HI)}(x, x_L) &\equiv \int \frac{p^+ dy^-}{2\pi} dy_1^- dy_2^- e^{ixp^+ y^- - ix_L p^+ (y_2^- - y_1^-)} (1 - e^{ix_L p^+ y_2^-}) \\
&\quad \times \langle A | \bar{\psi}_q(0) \frac{\gamma^+}{2} \psi_q(y^-) \bar{\psi}_{q_i}(y_2^-) \frac{\gamma^+}{2} \psi_{q_i}(y_1^-) | A \rangle \theta(-y_2^-) \theta(y^- - y_1^-), \tag{49}
\end{aligned}$$

$$\begin{aligned}
T_{qq_i}^{A(SI)}(x, x_L) &= \int \frac{p^+ dy^-}{2\pi} dy_1^- dy_2^- e^{i(x+x_L)p^+ y^-} (1 - e^{-ix_L p^+ y_2^-}) \\
&\quad \times \langle A | \bar{\psi}_q(0) \frac{\gamma^+}{2} \psi_q(y^-) \bar{\psi}_{q_i}(y_2^-) \frac{\gamma^+}{2} \psi_{q_i}(y_1^-) | A \rangle \theta(-y_2^-) \theta(y^- - y_1^-), \tag{50}
\end{aligned}$$

and  $T_{qq_i}^{A(HS)}(x, x_L) = T_{qq_i}^{A(HI)}(x, x_L) + T_{qq_i}^{A(SI)}(x, x_L)$ .

Note that the contribution from fragmentation of quark  $q_i$  or antiquark  $\bar{q}_i$  only comes from the central-cut diagram. This contribution is positive and is proportional to  $T_{q\bar{q}_i}^{A(HI)}(x, x_L) + T_{q\bar{q}_i}^{A(SI)}(x, x_L)$ , containing all four terms: hard-soft, double-hard and both interference terms. The gluon fragmentation comes only from the single-triple interferences (left and right-cut diagrams). Its contribution is therefore negative and partially cancels the production of  $q_i(\bar{q}_i)$  from the hard-soft rescattering. The cancellation is not complete since the gluon and quark fragmentation functions are different. The structure of this hard-soft rescattering (quark plus gluon) is very similar to the lowest order result of  $q\bar{q} \rightarrow g$  in Eq. (35). It contributes to the modification of the effective fragmentation function but does not contribute to the energy loss. The energy loss of the leading quark comes only from double-hard rescattering, since the leading quark fragmentation comes both from the central-cut and single-triple interferences, and the single-triple interference terms cancel the effect of hard-soft scattering for the leading fragmentation. Its net contribution is therefore proportional to  $T_{q\bar{q}_i(\bar{q}_i)}^{A(HI)}$ . Since the double-hard rescattering amounts to elastic  $qq_i(\bar{q}_i)$  scattering, the effective energy loss is essentially elastic energy loss as shown in Ref. [34]. There is, however, LPM suppression due to partial cancellation by single-triple interference contributions. For long formation time,  $1/x_L p^+ \gg R_A$ , the cancellation is complete. Therefore, LPM interference effectively imposes the lower limit  $x_L \geq 1/p^+ R_A$  on the fractional momentum carried by the second quark (antiquark).

#### 4.4 $qq \rightarrow qq$ scattering

For identical quark-quark scattering,  $qq \rightarrow qq$ , one has to include both  $t$  and  $u$ -channels, their interferences, and the related single-triple interference contributions. Using the same technique to identify and neglect the contact contributions, one can find the corresponding modification to the quark fragmentation function from Eqs. (48) and (A-45)-(A-49),

$$\begin{aligned}
\Delta D_{q \rightarrow h}^{(qq \rightarrow qq)}(z_h) &= \frac{C_F \alpha_s^2 x_B}{N_c Q^2} \int \frac{d\ell_T^2}{\ell_T^2} \int_{z_h}^1 \frac{dz}{z} \left\{ \frac{T_{qq}^{A(HS)}(x, x_L)}{f_q^A(x)} \right. \\
&\quad \times [D_{q \rightarrow h}(z_h/z) - D_{g \rightarrow h}(z_h/z)] \left( \frac{1 + (1-z)^2}{z^2} - \frac{1}{N_c} \frac{1}{z(1-z)} \right) \\
&\quad + \left[ D_{q \rightarrow h}(z_h/z) \left( \frac{1+z^2}{(1-z)^2} - \frac{1}{N_c} \frac{1}{z(1-z)} \right) \right. \\
&\quad \left. \left. + D_{g \rightarrow h}(z_h/z) \left( \frac{1 + (1-z)^2}{z^2} - \frac{1}{N_c} \frac{1}{z(1-z)} \right) \right] \frac{T_{qq}^{A(HI)}(x, x_L)}{f_q^A(x)} \right\} \\
&= \frac{C_F \alpha_s^2 x_B}{N_c Q^2} \int \frac{d\ell_T^2}{\ell_T^2} \int_{z_h}^1 \frac{dz}{z} \left\{ \frac{T_{qq}^{A(SI)}(x, x_L)}{f_q^A(x)} P_{qq \rightarrow qq}^{(s)}(z) [D_{q \rightarrow h}(z_h/z) \right. \\
&\quad \left. - D_{g \rightarrow h}(z_h/z)] + D_{q \rightarrow h}(z_h/z) P_{qq \rightarrow qq}(z) \frac{T_{qq}^{A(HI)}(x, x_L)}{f_q^A(x)} \right\}, \tag{51}
\end{aligned}$$

where the effective splitting functions are defined as

$$P_{qq \rightarrow qq}^{(s)}(z) = \frac{1 + (1-z)^2}{z^2} - \frac{1}{N_c} \frac{1}{z(1-z)}, \tag{52}$$

$$P_{qq \rightarrow qq}(z) = \frac{1 + (1-z)^2}{z^2} + \frac{1+z^2}{(1-z)^2} - \frac{2}{N_c} \frac{1}{z(1-z)}. \tag{53}$$

#### 4.5 $q\bar{q} \rightarrow q\bar{q}$ , $gg$ annihilation

The most complicated twist-four processes involving four quark field operators are quark-antiquark annihilation into two gluons or an identical quark-antiquark pair. We have to consider them together since they have similar single-triple interference processes and they involve the same kind of quark-antiquark correlation matrix elements,  $T_{q\bar{q}}^{(i)}(x, x_L)$ , ( $i = HI, SI, HS$ ).

For notation purpose, we first factor out the common factor  $(C_F/N_c)\alpha_s^2 x_B/Q^2/f_q^A(x)$  and

the integration over  $\ell_T$  and  $z$  and define

$$\Delta D_{q \rightarrow h}^{(q\bar{q} \rightarrow gg, q\bar{q})}(z_h) \equiv \frac{C_F}{N_c} \frac{\alpha_s^2 x_B}{Q^2 f_q^A(x)} \int \frac{d\ell_T^2}{\ell_T^2} \int_{z_h}^1 \frac{dz}{z} \Delta \widetilde{D}_{q \rightarrow h}^{(q\bar{q} \rightarrow gg, q\bar{q})}(z_h, z, x, x_L). \quad (54)$$

After rearranging the phase factors and identifying (by combining central, left and right cut diagrams) and neglecting contact contributions we can list in the following the twist-four corrections to the quark fragmentation from the hard partonic parts of each cut diagram (see Appendix A):

Fig. 5 ( $t$ -channel  $q\bar{q} \rightarrow gg$ ),

$$\begin{aligned} \Delta \widetilde{D}_{q \rightarrow h(5)}^{(q\bar{q} \rightarrow gg, q\bar{q})} &= D_{g \rightarrow h}(z_h/z) 2C_F \left[ \frac{1 + (1-z)^2}{z(1-z)} + \frac{1+z^2}{z(1-z)} \right] T_{q\bar{q}}^{A(HI)}(x, x_L) \\ &+ [D_{g \rightarrow h}(z_h/z) - D_{q \rightarrow h}(z_h/z)] 2C_F \frac{1+z^2}{z(1-z)} T_{q\bar{q}}^{A(SI)}(x, x_L); \end{aligned} \quad (55)$$

Fig. 6 (interference between  $u$  and  $t$ -channel of  $q\bar{q} \rightarrow gg$ ),

$$\begin{aligned} \Delta \widetilde{D}_{q \rightarrow h(6)}^{(q\bar{q} \rightarrow gg, q\bar{q})} &= D_{g \rightarrow h}(z_h/z) \frac{-4(C_F - C_A/2)}{z(1-z)} T_{q\bar{q}}^{A(HI)}(x, x_L) \\ &+ [D_{g \rightarrow h}(z_h/z) - D_{q \rightarrow h}(z_h/z)] \frac{-2(C_F - C_A/2)}{z(1-z)} T_{q\bar{q}}^{A(SI)}(x, x_L); \end{aligned} \quad (56)$$

Fig. 7 ( $s$ -channel of  $q\bar{q} \rightarrow gg$ ),

$$\Delta \widetilde{D}_{q \rightarrow h(7)}^{(q\bar{q} \rightarrow gg, q\bar{q})} = D_{g \rightarrow h}(z_h/z) 4C_A \frac{(1-z+z^2)^2}{z(1-z)} T_{q\bar{q}}^{A(HI)}(x, x_L); \quad (57)$$

Figs. 8 and 9 (interference of  $s$  and  $t$ -channel  $q\bar{q} \rightarrow gg$ ),

$$\begin{aligned} \Delta \widetilde{D}_{q \rightarrow h(8+9)}^{(q\bar{q} \rightarrow gg, q\bar{q})} &= D_{g \rightarrow h}(z_h/z) (-2C_A) \left[ \frac{1+z^3}{z(1-z)} + \frac{1+(1-z)^3}{z(1-z)} \right] \\ &\quad \times T_{q\bar{q}}^{A(HI)}(x, x_L) + C_A \left[ D_{q \rightarrow h}(z_h/z) \frac{1+z^3}{z(1-z)} \right. \\ &\quad \left. + D_{g \rightarrow h}(z_h/z) \frac{1+(1-z)^3}{z(1-z)} \right] \times [T_{q\bar{q}}^{A(I2)}(x, x_L) - T_{q\bar{q}}^{A(I)}(x, x_L)]; \end{aligned} \quad (58)$$

Fig. 10 ( $s$ -channel of  $q\bar{q} \rightarrow q\bar{q}$ ),

$$\Delta \widetilde{D}_{q \rightarrow h(10)}^{(q\bar{q} \rightarrow gg, q\bar{q})} = [D_{q \rightarrow h}(z_h/z) + D_{\bar{q} \rightarrow h}(z_h/z)] [z^2 + (1-z)^2] \times T_{q\bar{q}}^{A(H)}(x, x_L), \quad (59)$$

Fig. 11 ( $t$ -channel of  $q\bar{q} \rightarrow q\bar{q}$ ), similar to Eq. (44),

$$\begin{aligned} \Delta \widetilde{D}_{q \rightarrow h(11)}^{(q\bar{q} \rightarrow gg, q\bar{q})} &= D_{q \rightarrow h}(z_h/z) \frac{1+z^2}{(1-z)^2} T_{q\bar{q}}^{A(HI)}(x, x_L) \\ &+ D_{\bar{q} \rightarrow h}(z_h/z) \frac{1+(1-z)^2}{z^2} T_{q\bar{q}}^{A(HS)}(x, x_L) \\ &- D_{g \rightarrow h}(z_h/z) \frac{1+(1-z)^2}{z^2} T_{q\bar{q}}^{A(SI)}(x, x_L); \end{aligned} \quad (60)$$

Figs. 12 and 13 (interference between  $s$  and  $t$ -channel  $q\bar{q} \rightarrow q\bar{q}$ ),

$$\begin{aligned} \Delta \widetilde{D}_{q \rightarrow h(12+13)}^{(q\bar{q} \rightarrow gg, q\bar{q})} &= -4(C_F - C_A/2) \left[ D_{q \rightarrow h}(z_h/z) \frac{z^2}{1-z} \right. \\ &\quad \left. + D_{\bar{q} \rightarrow h}(z_h/z) \frac{(1-z)^2}{z} \right] T_{q\bar{q}}^{A(HI)}(x, x_L) \\ &+ 2(C_F - C_A/2) \left[ D_{q \rightarrow h}(z_h/z) \frac{z^2}{1-z} + D_{g \rightarrow h}(z_h/z) \frac{(1-z)^2}{z} \right] \\ &\quad \times [T_{q\bar{q}}^{A(I2)}(x, x_L) - T_{q\bar{q}}^{A(I)}(x, x_L)]; \end{aligned} \quad (61)$$

Figs. 15 and 16 (two additional single-triple interference diagrams),

$$\begin{aligned} \Delta \widetilde{D}_{q \rightarrow h(15+16)}^{(q\bar{q} \rightarrow gg, q\bar{q})} &= -2C_F \left[ D_{q \rightarrow h}(z_h/z) \frac{1+z^2}{1-z} \right. \\ &\quad \left. + D_{g \rightarrow h}(z_h/z) \frac{1+(1-z)^2}{z} \right] T_{q\bar{q}}^{A(I2)}(x, x_L). \end{aligned} \quad (62)$$

Most processes involve both  $T^{A(HI)}(x, x_L)$  for double-hard rescattering with interference and  $T^{A(SI)}(x, x_L)$  for hard-soft rescattering with interference. All the  $s$ -channel (Figs. 7 and 10) processes involve double-hard scattering only. Therefore, they depend only on the  $T_{q\bar{q}}^{A(H)}(x, x_L) = T_{q\bar{q}}^{A(HI)}(x, x_L) + T_{q\bar{q}}^{A(I)}(x, x_L)$ . For interference between single and triple scattering (left and right-cut diagrams in Figs. 8, 9, 12, 13, 15 and 16), where a hard rescattering with the second quark (antiquark) follows a soft rescattering with the third antiquark (quark), only interference matrix elements,  $T_{q\bar{q}}^{A(I)}(x, x_L)$  and  $T_{q\bar{q}}^{A(I2)}(x, x_L)$ , are involved. Here,

$$T_{q\bar{q}}^{A(I2)}(x, x_L) \equiv \int \frac{p^+ dy^-}{2\pi} dy_1^- dy_2^- e^{ixp^+ y^- + ix_L p^+ y_2^-}$$

$$\begin{aligned}
& \times \langle A | \bar{\psi}_q(0) \frac{\gamma^+}{2} \psi_q(y^-) \bar{\psi}_q(y_1^-) \frac{\gamma^+}{2} \psi_q(y_2^-) | A \rangle \theta(-y_2^-) \theta(y^- - y_1^-) \\
& = \int \frac{p^+ dy^-}{2\pi} dy_1^- dy_2^- e^{ixp^+ y^- + ix_L p^+ (y^- - y_1^-)} \\
& \times \langle A | \bar{\psi}_q(0) \frac{\gamma^+}{2} \psi_q(y^-) \bar{\psi}_q(y_1^-) \frac{\gamma^+}{2} \psi_q(y_2^-) | A \rangle \theta(-y_2^-) \theta(y^- - y_1^-) , \tag{63}
\end{aligned}$$

is a new type of interference matrix elements that is only associated with this type of single-triple interference processes. One can categorize the above contributions according to the associated two-quark correlation matrix elements and rewrite the above contributions as,

$$\begin{aligned}
\Delta \widetilde{D}_{q \rightarrow h(HI)}^{q\bar{q} \rightarrow q\bar{q}, gg} &= T_{q\bar{q}}^{A(HI)}(x, x_L) [D_{g \rightarrow h}(z_h/z) P_{q\bar{q} \rightarrow gg}(z) + D_{q \rightarrow h}(z_h/z) P_{q\bar{q} \rightarrow q\bar{q}}(z) \\
& \quad + D_{\bar{q} \rightarrow h}(z_h/z) P_{q\bar{q} \rightarrow q\bar{q}}(1-z)] \tag{64}
\end{aligned}$$

$$\begin{aligned}
\Delta \widetilde{D}_{q \rightarrow h(SI)}^{q\bar{q} \rightarrow q\bar{q}, gg} &= T_{q\bar{q}}^{A(SI)}(x, x_L) \left\{ \left[ \frac{C_A}{z(1-z)} + 2C_F \frac{z}{1-z} - \frac{1+(1-z)^2}{z^2} \right] \right. \\
& \quad \times D_{g \rightarrow h}(z_h/z) - D_{q \rightarrow h}(z_h/z) \left[ \frac{C_A}{z(1-z)} + 2C_F \frac{z}{1-z} \right] \\
& \quad \left. + D_{\bar{q} \rightarrow h}(z_h/z) \frac{1+(1-z)^2}{z^2} \right\} \\
& = T_{q\bar{q}}^{A(SI)}(x, x_L) \left\{ [D_{q \rightarrow h}(z_h/z) - D_{g \rightarrow h}(z_h/z)] \left[ P_{q\bar{q} \rightarrow q\bar{q}}^{(s)}(z) \right. \right. \\
& \quad \left. \left. - 2C_F \frac{1+z^2}{z(1-z)} \right] + [D_{\bar{q} \rightarrow h}(z_h/z) - D_{q \rightarrow h}(z_h/z)] \frac{1+(1-z)^2}{z^2} \right\} \tag{65}
\end{aligned}$$

$$\begin{aligned}
\Delta \widetilde{D}_{q \rightarrow h(I)}^{q\bar{q} \rightarrow q\bar{q}, gg} &= T_{q\bar{q}}^{A(I)}(x, x_L) \left\{ \left[ C_A \frac{4(1-z+z^2)^2-1}{z(1-z)} - 2C_F \frac{(1-z)^2}{z} \right] \right. \\
& \quad \times D_{g \rightarrow h}(z_h/z) + [z^2 + (1-z)^2] D_{\bar{q} \rightarrow h}(z_h/z) \\
& \quad \left. + D_{q \rightarrow h}(z_h/z) \left[ z^2 + (1-z)^2 - \frac{C_A}{z(1-z)} - 2C_F \frac{z^2}{1-z} \right] + \right\} \\
& \quad + T_{q\bar{q}}^{A(I2)}(x, x_L) \left\{ D_{q \rightarrow h}(z_h/z) \left[ \frac{C_A}{z(1-z)} - \frac{2C_F}{1-z} \right] \right. \\
& \quad \left. + D_{g \rightarrow h}(z_h/z) \left[ \frac{C_A}{z(1-z)} - \frac{2C_F}{z} \right] \right\} , \tag{66}
\end{aligned}$$

where  $P_{q\bar{q} \rightarrow q\bar{q}}^{(s)}(z)$  is given in Eq. (52) and the effective splitting functions for  $q\bar{q} \rightarrow gg$  and  $q\bar{q} \rightarrow q\bar{q}$  are defined as

$$P_{q\bar{q} \rightarrow gg}(z) = 2C_F \frac{z^2 + (1-z)^2}{z(1-z)} - 2C_A [z^2 + (1-z)^2] ; \tag{67}$$

$$P_{q\bar{q} \rightarrow q\bar{q}}(z) = z^2 + (1-z)^2 + \frac{1+z^2}{(1-z)^2} + \frac{2}{N_c} \frac{z^2}{1-z} , \tag{68}$$

which come from the complete matrix elements of  $q\bar{q} \rightarrow gg$  and  $q\bar{q} \rightarrow q\bar{q}$  scattering (see Appendix A-3). Again, double-hard rescattering corresponds to the elastic scattering of the leading quark with another antiquark in the medium and the interference contributions. The structure of the hard-soft rescattering contribution we identify above shows the same kind of gluon-quark (or quark-antiquark) mixing in the fragmentation functions and does not contribute to the energy loss of the leading quark. The unique contributions in the  $q\bar{q} \rightarrow q\bar{q}, gg$  processes are the interference-only contributions. They mainly come from single-triple interference processes in the multiple parton scattering.

## 5 Modification due to quark-gluon mixing

We have so far cast the modification of the quark fragmentation function due to quark-quark (antiquark) scattering (or annihilation) in a form similar to the DGLAP evolution equation in vacuum. In fact, one can also view the evolution of fragmentation functions in vacuum as modification due to final-state gluon radiation. In both cases, the modification at large  $z_h$  is mainly determined by the singular behavior of the splitting functions for  $z \rightarrow 1$ , whereas the modifications at small  $z_h$  is dominated by the singular behavior of the splitting function for  $z \rightarrow 0$ .

Let us first focus on the modification at large  $z_h$ . A careful examination of the contributions from all possible processes shows that the dominant modification to the effective quark fragmentation function comes from the  $t$ -channel of double hard quark-quark scattering processes,

$$\begin{aligned}
\Delta D_{q \rightarrow h}(z_h) &\sim \frac{C_F}{N_c} \frac{\alpha_s^2 x_B}{Q^2} \sum_{q_i} \int \frac{d\ell_T^2}{\ell_T^2} \int_{z_h}^1 \frac{dz}{z} D_{q \rightarrow h}\left(\frac{z_h}{z}\right) \left[ \frac{T_{qq_i}^{A(HI)}(x, x_L)}{f_q^A(x)} \right. \\
&\quad \left. \times \frac{1+z^2}{(1-z)_+^2} + \delta(1-z) \Delta_{q_i}(\ell_T^2) \right] \\
&= \frac{C_F}{N_c} \alpha_s^2 \sum_{q_i} \int \frac{d\ell_T^2}{\ell_T^4} \int_{z_h}^1 \frac{dz}{z} D_{q \rightarrow h}\left(\frac{z_h}{z}\right) \left[ \frac{x_L T_{qq_i}^{A(HI)}(x, x_L)}{f_q^A(x)} \right. \\
&\quad \left. \times \frac{z(1+z^2)}{(1-z)_+} + \delta(1-z) \Delta_{q_i}(\ell_T^2) \right], \tag{69}
\end{aligned}$$

where the summation is over all possible quark and antiquark flavors including  $q_i = q, \bar{q}$  and  $\Delta_{q_i}(\ell_T^2)$  represents the contribution from virtual corrections. We have expressed the modification in a form that it is proportional to the matrix elements  $x_L T_{qq_i}^{A(HI)}(x, x_L)/f_q^A(x) \sim A^{1/3} x_L f_{q_i}^N(x_L)$  as compared to the modification from quark-gluon scattering where the corresponding matrix element [Eq. (9)] is  $T_{qg}^{A(HI)}(x, x_L)/f_q^A(x) \sim A^{1/3} x_L G^N(x_L)$ . Here,  $f_{q_i}^N(x)$  and  $G^N(x)$  are quark and gluon distributions, respectively, in a nucleon. This leading contribution to the modification from quark-quark scattering is very similar in

form to that from quark-gluon scattering [see Eq. (7)]. However, it is smaller due to the different color factors  $C_F/C_A = 4/9$  and the different quark and gluon distributions,  $f_{q_i}^N(x_L)$  and  $G^N(x_L)$  in a nucleon. Because of LPM interference, small angle scattering with long formation time  $\tau_f = 1/x_L p^+$  is suppressed, leading to a minimum value of  $x_L \geq x_A = 1/m_N R_A = 0.043$  for a  $Kr$  target. For this value of  $x_L$ , the ratio

$$\frac{\sum_{q_i} f_{q_i}^N(x_L, Q^2)}{G^N(x_L, Q^2)} \geq 1.40/1.85 \sim 0.75, \quad (70)$$

at  $Q^2 = 2 \text{ GeV}^2$  according the CTEG4HJ parameterization [35]. Therefore, one has to include the effect of quark-quark scattering for a complete calculation of the total quark energy loss and medium modification of quark fragmentation functions.

In a weakly coupled and fully equilibrated quark-gluon plasma, quark to gluon number density ratio is  $\rho_q/\rho_g = n_f(3/2)N_c/(N_c^2 - 1) = 9n_f/16$ . An asymptotically energetic jet in an infinitely large medium actually probes the small  $x = \langle q_T^2 \rangle / 2ET$  regime, where quark-antiquark pairs and gluons are predominantly generated by thermal gluons through pQCD evolution. In this ideal scenario one expects  $N_q/N_g \sim 1/4C_A = 1/12$  and therefore can neglect quark-quark scattering. The modification of quark fragmentation function will be dominated by quark-gluon rescattering. However, for moderate jet energy  $E \approx 20 \text{ GeV}$  and a finite medium  $L \sim 5 \text{ fm}$ , parton distributions in a quark-gluon plasma are close to the thermal distribution. In particular, if quark and gluon production is dominated by non-perturbative pair production from strong color fields in the initial stage of heavy-ion collisions [36], the quark to gluon ratio is comparable to the equilibrium value. In this case, we should take into account the medium modification of the quark fragmentation functions by quark-quark scattering.

An important double hard process in quark-quark (antiquark) scattering is  $q\bar{q} \rightarrow gg$  [Eq. (64)]. In this process, the annihilation converts the initial quark into two final gluons that subsequently fragment into hadrons. This will lead to suppression of the leading hadrons not only because of energy loss (energy carried away by the other gluon) but also due to the softer behavior of gluon fragmentation functions at large  $z_h$ . Even though the leading behavior of the effective splitting function [Eq. (67)]

$$P_{q\bar{q} \rightarrow gg}(z) \approx 2C_F \frac{z^2 + (1-z)^2}{z(1-z)} \quad (71)$$

is not as dominating as that of  $t$ -channel quark-quark scattering, it is enhanced by a color factor  $2C_F = 8/3$ . One expects this to make a significant contribution to the medium modification at intermediate  $z_h$ .

In high-energy heavy-ion collisions, the ratios of initial production rates for valence quarks, gluons and antiquarks vary with the transverse momentum  $p_T$ . Gluon production rate dominates at low  $p_T$  while the fraction of valence quark jets increases at large  $p_T$ .



Quarks are more likely to fragment into protons than antiprotons, while gluons fragment into protons and antiprotons with equal probabilities. Therefore, the ratio of large  $p_T$  antiproton and proton yields in  $p + p$  collisions is smaller than 1 and decreases with  $p_T$  as the fraction of valence quark jets increases. Since gluons are expected to lose more energy than quark jets, one would naively expect to see the antiproton to proton ratio  $\bar{p}/p$  becomes smaller due to jet quenching. However, if the quark-gluon conversion due to  $q\bar{q} \rightarrow gg$  becomes important, one would expect that the fractions of quark and gluon jets are modified toward their equilibrium values. The final  $\bar{p}/p$  ratio could be larger than or comparable to that in  $p + p$  collisions. Such a scenario of quark-gluon conversion was recently considered in Ref. [37] via a master rate equation.

The mixing between quark and gluon jets also happens at the lowest order of quark-antiquark annihilation as shown in Fig. 3. At NLO, all hard-soft quark-quark (antiquark) scattering processes have this kind of mixing between quark and gluon fragmentation functions. Their contributions generally have the form,

$$\begin{aligned} \frac{C_F}{N_c} \frac{\alpha_s^2 x_B}{Q^2} \sum_{q_i} \int \frac{d\ell_T^2}{\ell_T^2} \int_{z_h}^1 \frac{dz}{z} \left[ D_{q_i \rightarrow h}\left(\frac{z_h}{z}\right) - D_{g \rightarrow h}\left(\frac{z_h}{z}\right) \right] \\ \times P_{qq_i \rightarrow qq_i}(z) \frac{T_{qq_i}^{A(SI)}(x, x_L)}{f_q^A(x)}, \end{aligned} \quad (72)$$

where again the summation over the quark flavor includes  $q_i = q, \bar{q}$ . This mixing does not occur on the probability but rather on the amplitude level since it involves interferences between single and triple scattering. Therefore, this contribution depends on the difference between gluon and quark fragmentation functions [Eq. (35)] and can be positive or negative in different region of  $z_h$ . Nevertheless, they contribute to the modification of the effective quark fragmentation function and the flavor dependence of the final hadron spectra.

## 6 Flavor dependence of the medium modified fragmentation

Summing all contributions to quark-quark (antiquark) double scattering as listed in Section 4, we can express the total twist-four correction up to  $\mathcal{O}(\alpha_s^2)$  to the quark fragmentation function as

$$\begin{aligned} \Delta D_{q \rightarrow h}(z_h) = \frac{C_F}{N_c} 2\pi \frac{\alpha_s x_B}{Q^2} \left\{ 2 [D_{g \rightarrow h}(z_h) - D_{q \rightarrow h}(z_h)] \frac{T_{q\bar{q}}^{A(H)}(x, 0)}{f_q^A(x)} \right. \\ \left. + \frac{\alpha_s}{2\pi} \int \frac{d\ell_T^2}{\ell_T^2} \int_{z_h}^1 \frac{dz}{z} \sum_{a,b,i} D_{b \rightarrow h}(z_h/z) P_{qa \rightarrow b}^{(i)}(z) \frac{T_{qa}^{A(i)}(x, x_L)}{f_q^A(x)} \right\}, \end{aligned} \quad (73)$$

where the summation is over all possible  $q + a \rightarrow b + X$  processes and all different matrix elements  $T_{qa}^{A(i)}(x, x_L)$  ( $i = HI, SI, I, I2$ ), which will be four basic matrix elements we will use. The effective splitting functions  $P_{qa \rightarrow b}^{(i)}(z)$  are listed in Appendix A-2. One should also include virtual corrections which can be constructed from the real corrections through unitarity constraints [18].

Similarly, we can also write down the twist-four corrections to antiquark fragmentation in a nuclear medium,

$$\begin{aligned} \Delta D_{\bar{q} \rightarrow h}(z_h) = & \frac{C_F}{N_c} 2\pi \frac{\alpha_s x_B}{Q^2} \left\{ 2 [D_{g \rightarrow h}(z_h) - D_{\bar{q} \rightarrow h}(z_h)] \frac{T_{\bar{q}q}^{A(H)}(x, 0)}{f_{\bar{q}}^A(x)} \right. \\ & \left. + \frac{\alpha_s}{2\pi} \int \frac{d\ell_T^2}{\ell_T^2} \int_{z_h}^1 \frac{dz}{z} \sum_{a,b,i} D_{b \rightarrow h}(z_h/z) P_{\bar{q}a \rightarrow b}^{(i)}(z) \frac{T_{\bar{q}a}^{A(i)}(x, x_L)}{f_{\bar{q}}^A(x)} \right\}, \end{aligned} \quad (74)$$

where the matrix elements  $T_{\bar{q}a}^{A(i)}(x, x_L)$  and the effective splitting functions  $P_{\bar{q}a \rightarrow b}^{(i)}(z)$  can be obtained from the corresponding ones for quarks. Given a model for the two-quark correlation functions, one will be able to use the above expressions to numerically evaluate twist-four corrections to the quark (antiquark) fragmentation functions. In this paper, we will instead give a qualitative estimate of the flavor dependence of the correction in DIS off a large nucleus.

For the purpose of a qualitative estimate, one can assume that all the twist-four two-quark correlation functions can be factorized, as has been done in Refs. [18,19,23,33],

$$\begin{aligned} & \int \frac{p^+ dy^-}{2\pi} dy_1^- dy_2^- e^{ix_1 p^+ y^- + ix_2 p^+ (y_1^- - y_2^-)} \theta(-y_2^-) \theta(y^- - y_1^-) \\ & \quad \times \langle A | \bar{\psi}_q(0) \frac{\gamma^+}{2} \psi_q(y^-) \bar{\psi}_{q_i}(y_1^-) \frac{\gamma^+}{2} \psi_{q_i}(y_2^-) | A \rangle \\ & \quad \approx \frac{C}{x_A} f_q^A(x_1) f_{q_i}^N(x_2), \end{aligned} \quad (75)$$

$$\begin{aligned} & \int \frac{p^+ dy^-}{2\pi} dy_1^- dy_2^- e^{ix_1 p^+ y^- + ix_2 p^+ (y_1^- - y_2^-) \pm ix_L p^+ y_2^-} \theta(-y_2^-) \theta(y^- - y_1^-) \\ & \quad \times \langle A | \bar{\psi}_q(0) \frac{\gamma^+}{2} \psi_{\bar{q}}(y^-) \bar{\psi}_{q_i}(y_1^-) \frac{\gamma^+}{2} \psi_{q_i}(y_2^-) | A \rangle \\ & \quad \approx \frac{C}{x_A} f_q^A(x_1) f_{q_i}^N(x_2) e^{-x_L^2/x_A^2}, \end{aligned} \quad (76)$$

where  $x_A = 1/m_N R_A$ ,  $m_N$  is the nucleon mass,  $R_A$  the nucleus size,  $f_{q_i}^N(x_2)$  is the antiquark distribution in a nucleon and  $C$  is assumed to be a constant, parameterizing the strength of two-parton correlations inside a nucleus. The integration over the position of the antiquark  $(y_1^- + y_2^-)/2$  in the twist-four two-quark correlation matrix elements gives rise to the nuclear enhancement factor  $1/x_A = m_N R_A = 0.21 A^{1/3}$ .

We should note that we set  $k_T = 0$  for the collinear expansion. As a consequence, the secondary quark field in the twist-four parton matrix elements will carry zero momentum in the soft-hard process. Finite intrinsic transverse momentum leads to higher-twist corrections. If a subset of the higher-twist terms in the collinear expansion can be resummed to restore the phase factors such as  $e^{ix_T p^+ y^-}$ , where  $x_T \equiv \langle k_T^2 \rangle / 2p^+ q^- z(1-z)$ , the soft quark fields in the parton matrix elements will carry a finite fractional momentum  $x_T$ .

Under such an assumption of factorization, one can obtain all the two-quark correlation matrix elements:

$$T_{q\bar{q}_i}^{A(HI)}(x, x_L) \approx \frac{C}{x_A} f_q^A(x) f_{\bar{q}_i}^N(x_L + x_T) [1 - e^{-x_L^2/x_A^2}], \quad (77)$$

$$T_{q\bar{q}_i}^{A(SI)}(x, x_L) \approx \frac{C}{x_A} f_q^A(x + x_L) f_{\bar{q}_i}^N(x_T) [1 - e^{-x_L^2/x_A^2}], \quad (78)$$

$$\begin{aligned} T_{q\bar{q}_i}^{A(I)}(x, x_L) &\approx T_{q\bar{q}_i}^{A(I2)}(x, x_L) \approx \frac{C}{x_A} f_q^A(x + x_L) f_{\bar{q}_i}^N(x_T) e^{-x_L^2/x_A^2} \\ &\approx \frac{C}{x_A} f_q^A(x) f_{\bar{q}_i}^N(x_L + x_T) e^{-x_L^2/x_A^2}. \end{aligned} \quad (79)$$

In the last approximation, we have assumed  $x_L \sim x_T \ll x$ . Similarly, one can obtain  $T_{q_i}^{A(i)}(x, x_L)$ ,  $T_{\bar{q}_i}^{A(i)}(x, x_L)$  and  $T_{\bar{q}_i}^{A(i)}(x, x_L)$ . With these forms of two-quark correlation matrix elements, we can estimate the flavor dependence of the nuclear modification to the quark (antiquark) fragmentation functions.

The lowest order corrections  $[\mathcal{O}(\alpha_s)]$  are very simple

$$\Delta D_{q \rightarrow h}^{(LO)}(z_h) \propto CA^{1/3} [D_{g \rightarrow h}(z_h) - D_{q \rightarrow h}(z_h)] f_{\bar{q}}^N(x_T), \quad (80)$$

$$\Delta D_{\bar{q} \rightarrow \bar{h}}^{(LO)}(z_h) \propto CA^{1/3} [D_{g \rightarrow \bar{h}}(z_h) - D_{\bar{q} \rightarrow \bar{h}}(z_h)] f_q^N(x_T). \quad (81)$$

We consider the dominant contribution from the fragmentation of a quark (antiquark) which is one of the valence quarks (antiquarks) of the final particle  $h$  (antiparticle  $\bar{h}$ ). The gluon fragmentation functions into  $h$  and  $\bar{h}$  are the same. For large  $z_h$ , the gluon fragmentation function is always softer than the valence quark (antiquark) fragmentation [38]. Therefore, the lowest order twist-four corrections are always negative for large  $z_h$ , leading to a suppression of the valence quark (antiquark) fragmentation function,  $D_{q_v \rightarrow h}(z_h) [D_{\bar{q}_v \rightarrow \bar{h}}(z_h)]$ . Consider those quarks that are also valence quarks of a nucleon:

$$n = udd \quad (82)$$

$$p = uud, \bar{p} = \bar{u}\bar{u}\bar{d}, \quad (82)$$

$$K^+ = u\bar{s}, K^- = \bar{u}s. \quad (83)$$

$$\pi^+, \pi^0, \pi^- = u\bar{d}, (u\bar{u} - d\bar{d})/\sqrt{2}, d\bar{u}. \quad (84)$$

One can find the following flavor dependence of the lowest order twist-four corrections

to the quark (antiquark) fragmentation functions,

$$\frac{\Delta D_{\bar{q}_v \rightarrow \bar{h}}^{(LO)}(z_h)}{\Delta D_{q_v \rightarrow h}^{(LO)}(z_h)} = \frac{-|\Delta D_{\bar{q}_v \rightarrow \bar{h}}^{(LO)}(z_h)|}{-|\Delta D_{q_v \rightarrow h}^{(LO)}(z_h)|} = \frac{f_{q_v}^N(x_T)}{f_{\bar{q}_v}^N(x_T)} > 1, \quad (85)$$

or

$$\frac{R_{\bar{q}_v \rightarrow \bar{h}}^{(LO)}(z_h)}{R_{q_v \rightarrow h}^{(LO)}(z_h)} = \frac{1 + \Delta D_{\bar{q}_v \rightarrow \bar{h}}^{(LO)}(z_h)/D_{\bar{q} \rightarrow \bar{h}}(z_h)}{1 + \Delta D_{q_v \rightarrow h}^{(LO)}(z_h)/D_{q \rightarrow h}(z_h)} < 1, \quad (86)$$

where  $R_{q_v \rightarrow h}^{(LO)}$  is the corresponding leading order suppression of the fragmentation function at large  $z_h$  for proton (anti-proton) and  $K^+$  ( $K^-$ ). Since pions contain both valence quark and antiquark, the suppression factors should be similar for all pions. For  $x_T \geq 0.043$ ,  $u(x)/\bar{u}(x) \geq 3$  and  $d(x)/\bar{d}(x) \geq 2$  [35]. Therefore, the modification of antiquark fragmentation functions due to quark-antiquark annihilation is significantly larger than that of a quark.

The flavor dependence of the NLO results are more complicated since they involve scattering with both quarks and antiquarks in the medium. One can observe first that effective splitting functions (or quark-quark scattering cross section) are the same for the  $t$ -channel  $qq' \rightarrow qq'$  and  $q\bar{q}' \rightarrow q\bar{q}'$  ( $q' \neq q$ ) scatterings,

$$P_{qq' \rightarrow b}^{(i)}(z) = P_{\bar{q}\bar{q}' \rightarrow b}^{(i)}(z) = P_{q\bar{q}' \rightarrow b}^{(i)}(z) = P_{\bar{q}q' \rightarrow b}^{(i)}(z). \quad (87)$$

For identical quark-quark scattering or quark-antiquark annihilation, one can separate the  $q\bar{q}$  annihilation splitting functions (or cross sections) into singlet and non-singlet contributions by singling out the  $t$ -channel contributions,

$$P_{q\bar{q} \rightarrow b}^{(i)}(z) \equiv P_{q\bar{q} \rightarrow b}^{(i)}(z) + \Delta P_{q\bar{q} \rightarrow b}^{N(i)}(z), \quad (88)$$

$$P_{\bar{q}q \rightarrow b}^{(i)}(z) \equiv P_{\bar{q}q \rightarrow b}^{(i)}(z) + \Delta P_{\bar{q}q \rightarrow b}^{N(i)}(z). \quad (89)$$

These singlet contributions to the modified fragmentation functions are,

$$\Delta D_{q \rightarrow h}^{S(NLO)}(z_h) \propto \frac{\alpha_s}{2\pi} A^{1/3} \int \frac{d\ell_T^2}{\ell_T^2} \sum_{b,q',i} D_{b \rightarrow h} \otimes P_{qq' \rightarrow b}^{(i)}(z_h) \times [f_{q'}^N(x_T) + f_{\bar{q}'}^N(x_T)] C^{(i)}, \quad (90)$$

$$\Delta D_{\bar{q} \rightarrow \bar{h}}^{S(NLO)}(z_h) \propto \frac{\alpha_s}{2\pi} A^{1/3} \int \frac{d\ell_T^2}{\ell_T^2} \sum_{b,q',i} D_{\bar{b} \rightarrow \bar{h}} \otimes P_{\bar{q}\bar{q}' \rightarrow \bar{b}}^{(i)}(z_h) \times [f_{q'}^N(x_T) + f_{\bar{q}'}^N(x_T)] C^{(i)}, \quad (91)$$

where the summation over  $q'$  now includes  $q'=q$  and  $C^{(i)}(x_L)$  are flavor-independent functions determined from Eqs. (77)-(79),

$$\begin{aligned} C^{(HI)} &= C^{(SI)} = C(x_L)(1 - e^{-x_L^2/x_A^2}), \\ C^{(I)} &= C^{(I2)} = C(x_L)e^{-x_L^2/x_A^2}, \end{aligned} \quad (92)$$

and  $C(x_L)$  is a common coefficient that is a function of  $x_L$ . Using  $P_{\bar{q}\bar{q}\rightarrow\bar{b}}^{(i)}(z) = P_{q\bar{q}\rightarrow b}^{(i)}(z)$ , one can conclude that the singlet contributions to the modified quark and antiquark fragmentation functions are the same,  $\Delta D_{q\rightarrow h}^{S(NLO)}(z_h) = \Delta D_{\bar{q}\rightarrow\bar{h}}^{S(NLO)}(z_h)$ .

The non-singlet contributions, mainly from  $s$ -channel and  $s$ - $t$  interferences, are,

$$\Delta D_{q\rightarrow h}^{N(NLO)}(z_h) \propto \frac{\alpha_s}{2\pi} A^{1/3} \int \frac{d\ell_T^2}{\ell_T^2} \sum_{b,i} D_{b\rightarrow h} \otimes \Delta P_{q\bar{q}\rightarrow b}^{N(i)}(z_h) f_{\bar{q}}^N(x_T) C^{(i)}, \quad (93)$$

$$\Delta D_{\bar{q}\rightarrow\bar{h}}^{N(NLO)}(z_h) \propto \frac{\alpha_s}{2\pi} A^{1/3} \int \frac{d\ell_T^2}{\ell_T^2} \sum_{\bar{b},i} D_{\bar{b}\rightarrow\bar{h}} \otimes \Delta P_{\bar{q}\bar{q}\rightarrow\bar{b}}^{N(i)}(z_h) f_q^N(x_T) C^{(i)}, \quad (94)$$

where again  $\Delta P_{q\bar{q}\rightarrow b}^{N(i)}(z) = \Delta P_{\bar{q}\bar{q}\rightarrow\bar{b}}^{N(i)}(z)$  due to crossing symmetry. We have listed all non-vanishing nonsinglet splitting functions  $\Delta P_{q\bar{q}\rightarrow b}^{N(i)}(z)$  in Appendix A-2.

We again consider the limit  $z_h \rightarrow 1$ . In this region the convolution in the modified fragmentation function is dominated by the large  $z \rightarrow 1$  behavior of the effective splitting functions. From the listed  $\Delta P_{q\bar{q}\rightarrow b}^{N(i)}(z)$  in Appendix A-2, we can obtain the leading contributions,

$$\begin{aligned} \sum_i C^{(i)} \Delta P_{q\bar{q}\rightarrow q}^{N(i)}(z) &\approx -4C_F \frac{C(x_L)}{1-z}, \\ \sum_i C^{(i)} \Delta P_{q\bar{q}\rightarrow g}^{N(i)}(z) &\approx 2 \left[ 2C_F + C_F(1 - e^{-x_L^2/x_A^2}) + C_A e^{-x_L^2/x_A^2} \right] \frac{C(x_L)}{1-z}, \end{aligned} \quad (95)$$

where we have also neglected terms proportional to  $1/N_c$ . All  $\Delta P_{q\bar{q}\rightarrow\bar{q}}^{N(i)}(z)$  are non-leading in the limit  $z \rightarrow 1$  and therefore can be neglected. With these leading contributions, the non-singlet modification to the quark and antiquark fragmentation functions can be estimated as

$$\begin{aligned} \Delta D_{q\rightarrow h}^{N(NLO)}(z_h) &\propto \frac{\alpha_s}{\pi} A^{1/3} \int \frac{d\ell_T^2}{\ell_T^2} \int_{z_h}^1 \frac{dz}{z} \left\{ D_{g\rightarrow h} \left( \frac{z_h}{z} \right) \left[ \frac{C(x_L)}{(1-z)_+} \right. \right. \\ &\quad \times \left( C_F(1 - e^{-x_L^2/x_A^2}) + C_A e^{-x_L^2/x_A^2} \right) + \delta(1-z) \Delta_1(\ell_T) \left. \right] \\ &\quad \left. + \left[ D_{g\rightarrow h} \left( \frac{z_h}{z} \right) - D_{q\rightarrow h} \left( \frac{z_h}{z} \right) \right] \right\} \end{aligned}$$

$$\times \left[ 2C_F \frac{C(x_L)}{(1-z)_+} + \delta(1-z)\Delta_2(\ell_T) \right] \left. \right\} f_{\bar{q}}^N(x_T), \quad (96)$$

$$\begin{aligned} \Delta D_{\bar{q} \rightarrow \bar{h}}^{N(NLO)}(z_h) &\propto \frac{\alpha_s}{\pi} A^{1/3} \int \frac{d\ell_T^2}{\ell_T^2} \int_{z_h}^1 \frac{dz}{z} \left\{ D_{g \rightarrow \bar{h}} \left( \frac{z_h}{z} \right) \left[ \frac{C(x_L)}{(1-z)_+} \right. \right. \\ &\times \left( C_F(1 - e^{-x_L^2/x_A^2}) + C_A e^{-x_L^2/x_A^2} \right) + \delta(1-z)\Delta_1(\ell_T) \left. \right] \\ &+ \left[ D_{g \rightarrow \bar{h}} \left( \frac{z_h}{z} \right) - D_{\bar{q} \rightarrow \bar{h}} \left( \frac{z_h}{z} \right) \right] \\ &\times \left. \left[ 2C_F \frac{C(x_L)}{(1-z)_+} + \delta(1-z)\Delta_2(\ell_T) \right] \right\} f_q^N(x_T), \quad (97) \end{aligned}$$

where  $\Delta_1(\ell_T)$  and  $\Delta_2(\ell_T)$  are from virtual corrections,

$$\begin{aligned} \Delta_1(\ell_T) = \int_0^1 \frac{dz}{1-z} \left\{ C_F C(x_L)|_{z=1} - [C_F(1 - e^{-x_L^2/x_A^2}) \right. \\ \left. + C_A e^{-x_L^2/x_A^2}] C(x_L) \right\}, \quad (98) \end{aligned}$$

$$\Delta_2(\ell_T) = \int_0^1 \frac{dz}{1-z} 2C_F [C(x_L)|_{z=1} - C(x_L)]. \quad (99)$$

Because of momentum conservation,  $C(x_L) = 0$  when  $x_L \rightarrow \infty$  for  $z = 1$ . Therefore, the above virtual corrections are always negative. At large  $z_h$ , these virtual corrections dominate over the real ones.

There are two kinds of non-singlet contributions in the expressions given above. One that is proportional to gluon fragmentation functions is due to quark-antiquark annihilation into gluons which then fragment. The fragmenting gluon not only carries less energy than the initial quark but also has a softer fragmentation function, leading to suppression of the final leading hadrons. The second type of contributions is proportional to  $D_{g \rightarrow h}(z_h) - D_{q \rightarrow h}(z_h)$  and therefore mixes quark and gluon fragmentation functions, similarly as the lowest order quark-antiquark annihilation processes [see Eqs. (80) and (81)]. Since a gluon fragmentation function is softer than a quark one, the real corrections from this type of processes are positive for small  $z_h$  and negative for large  $z_h$ . The virtual corrections have just the opposite behavior. Therefore, the second type of contributions will reduce the total net modification. For intermediate values of  $z_h$  where  $2D_{g \rightarrow h}(z_h) > D_{q \rightarrow h}(z_h)$ , the net effect is still the suppression of the effective fragmentation functions for leading hadrons.

Since  $f_q^N(x_T) > f_{\bar{q}}^N(x_T)$ , we can conclude that the LO and NLO combined non-singlet suppression for antiquark fragmentation into valence hadrons is larger than that for quark fragmentation into valence hadrons. This qualitatively explains the flavor dependence of nuclear suppression of leading hadrons in DIS off heavy nuclear targets as measured by the HERMES experiment [25,26]. The ratio of differential semi-inclusive cross sections

for nucleus and deuteron targets were used to study the nuclear suppression of the fragmentation functions. It was observed that suppression of leading anti-proton is stronger than for leading proton and  $K^-$  suppression is stronger than  $K^+$ . In the valence quark fragmentation picture, the leading proton ( $K^+$ ) is produced mainly from  $u, d$  ( $u$ ) quark fragmentation while anti-protons come primarily from  $\bar{u}, \bar{d}$  ( $\bar{u}$ ) fragmentation. Therefore, HERMES data are consistent with stronger suppression of antiquark fragmentation.

Since gluon bremsstrahlung and the singlet  $qq_i(\bar{q}_i)$  scattering also suppress quark and antiquark fragmentation, but independently of quark flavor, one has to include all the processes in order to have a complete and quantitative numerical evaluation of the flavor dependence of the nuclear modification of the quark fragmentation functions. Furthermore, the NLO contributions are proportional to  $\alpha_s \ln(Q^2)/2\pi$ . They are as important as the lowest order correction for large values of  $Q^2$ . In principle, one should resum these higher order corrections via solving a set of coupled DGLAP evolution equations, including medium modification for gluon fragmentation functions. The contributions from quark-quark (antiquark) scattering derived in this paper will be an important part of the complete description. Detailed numerical study of the effect of quark-quark (antiquark) scattering will be possible only after the completion of this complete description in the future.

## 7 Summary

Utilizing the generalized factorization framework for twist-four processes we have studied the nuclear modification of quark and antiquark fragmentation functions (FF) due to quark-quark (antiquark) double scattering in dense nuclear matter up to order  $\mathcal{O}(\alpha_s^2)$ . We calculated and analyzed the complete set of all possible cut diagrams. The results can be categorized into contributions from double-hard, hard-soft processes and their interferences. The double-hard rescatterings correspond to elastic scattering of the leading quark with another medium quark. It requires the second quark to carry a finite fractional momentum  $x_L$ . Therefore, the energy loss of the leading quark through such processes can be identified as elastic energy loss at order  $\mathcal{O}(\alpha_s^2)$ . The quark energy loss and modification of quark fragmentation functions are dominated by the  $t$ -channel of quark-quark (antiquark) scattering and are shown to be similar to that caused by quark-gluon scattering. The contribution from quark-quark scattering is smaller than that from quark-gluon scattering by a factor of  $C_F/C_A$  times the ratio of quark and gluon distribution functions in the medium. We have shown that such contributions are not negligible for realistic kinematics and finite medium size. The soft-hard rescatterings mix gluon and quark scattering, in the same way as the lowest order  $q\bar{q} \rightarrow g$  processes. Such processes modifies the final hadron spectra or effective fragmentation functions but do not contribute to energy loss of the leading quark. For  $q\bar{q} \rightarrow q\bar{q}, gg$  processes, there also exist pure interference contributions mainly coming from single-triple-scattering interference.

With a simple model of a factorized two-quark correlation functions, we further investi-

gated the flavor dependence of the medium modified quark fragmentation functions in a large nucleus. We identified the flavor dependent part of the modification and find that the nuclear modification for an antiquark fragmentation into a valence hadron is larger than that of a quark. This offers an qualitative explanation for the flavor dependence of the leading hadron suppression in semi-inclusive DIS off nuclear targets as observed by the HERMES experiment [25,26].

## Acknowledgements

The authors thank Jian-Wei Qiu and Enke Wang for helpful discussion. This work was supported by NSFC under project No. 10405011, by MOE of China under project IRT0624, by Alexander von Humboldt Foundation, by BMBF, by the Director, Office of Energy Research, Office of High Energy and Nuclear Physics, Divisions of Nuclear Physics, of the U.S. Department of Energy under Contract No. DE-AC02-05CH11231, and by the US NSF under Grant No. PHY-0457265, the Welch Foundation under Grant No. A-1358.

## A-1 Hard partonic parts for quark-quark double scattering

In Section 3 we have discussed the calculation of the hard part of one example cut-diagram (Fig. 5) in detail. In this appendix we list the results for all possible real corrections to quark-quark (antiquark) double scattering in the next-to-leading order  $\mathcal{O}(\alpha_s^2)$ . There are a total of 12 diagrams as illustrated in Figs. 5-16. For the purpose of abbreviation, we will suppress the variables in the notations of partonic hard parts

$$\overline{H}^D \equiv \overline{H}^D(y^-, y_1^-, y_2^-, x, p, q, z_h), \quad (\text{A-1})$$

and phase factor functions

$$\overline{I} \equiv \overline{I}(y^-, y_1^-, y_2^-, x, , x_L, p). \quad (\text{A-2})$$

We first consider all  $q\bar{q} \rightarrow gg$  annihilation diagrams with different possible cuts. The contributions of Fig. 5 are:

$$\begin{aligned} \overline{H}_{5,C}^D &= \frac{\alpha_s^2 x_B}{Q^2} \int \frac{d\ell_T^2}{\ell_T^2} \int_{z_h}^1 \frac{dz}{z} \overline{I}_{5,C} D_{g \rightarrow h}(z_h/z) \\ &\quad \times \left[ 2 \frac{1+z^2}{z(1-z)} + 2 \frac{1+(1-z)^2}{z(1-z)} \right] \frac{C_F^2}{N_c}, \end{aligned} \quad (\text{A-3})$$



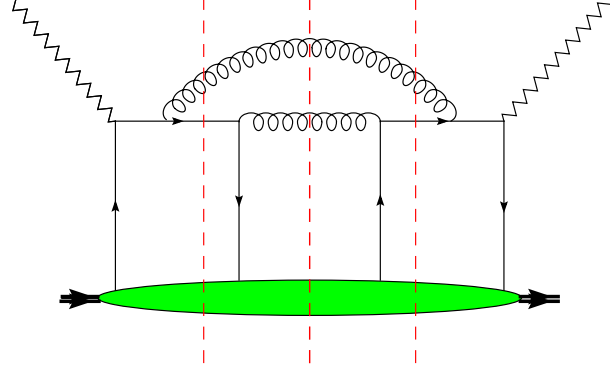

Fig. 5. The  $t$ -channel of  $q\bar{q} \rightarrow gg$  annihilation diagram with three possible cuts, central(C), left(L) and right(R).

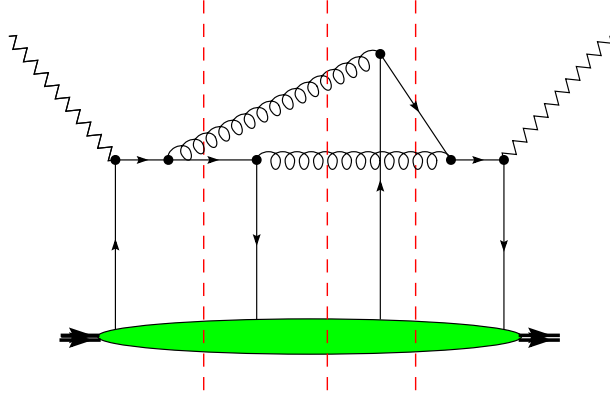

Fig. 6. The interference between  $t$  and  $u$ -channel of  $q\bar{q} \rightarrow gg$  annihilation.

$$\begin{aligned} \bar{I}_{5,C} &= \theta(-y_2^-) \theta(y^- - y_1^-) e^{i(x+x_L)p^+y^-} \\ &\quad \times (1 - e^{-ix_L p^+ y_2^-}) (1 - e^{-ix_L p^+ (y^- - y_1^-)}), \end{aligned} \quad (\text{A-4})$$

$$\begin{aligned} \bar{H}_{5,L(R)}^D &= \frac{\alpha_s^2 x_B}{Q^2} \int \frac{d\ell_T^2}{\ell_T^2} \int_{z_h}^1 \frac{dz}{z} \bar{I}_{5,L(R)} \left[ D_{q \rightarrow h}(z_h/z) 2 \frac{1+z^2}{z(1-z)} \right. \\ &\quad \left. + D_{g \rightarrow h}(z_h/z) 2 \frac{1+(1-z)^2}{z(1-z)} \right] \frac{C_F^2}{N_c}, \end{aligned} \quad (\text{A-5})$$

$$\bar{I}_{5,L} = -\theta(y_1^- - y_2^-) \theta(y^- - y_1^-) e^{i(x+x_L)p^+y^-} (1 - e^{-ix_L p^+ (y^- - y_1^-)}), \quad (\text{A-6})$$

$$\bar{I}_{5,R} = -\theta(-y_2^-) \theta(y_2^- - y_1^-) e^{i(x+x_L)p^+y^-} (1 - e^{-ix_L p^+ y_2^-}). \quad (\text{A-7})$$

Here we have included the fragmentation of both final-state partons.

The contributions from Fig. 6 are:

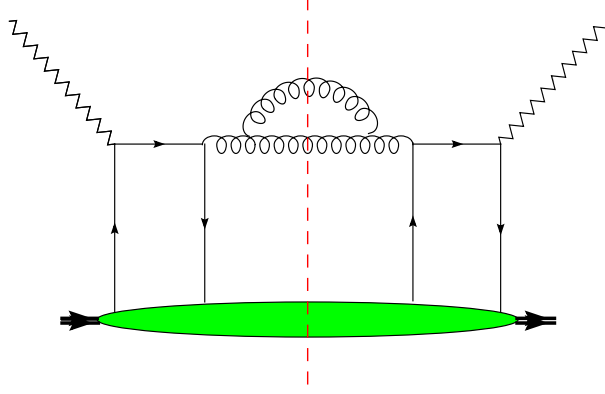

Fig. 7. The  $s$ -channel of  $q\bar{q} \rightarrow gg$  annihilation diagram with only a central-cut.

$$\begin{aligned} \overline{H}_{6,C}^D &= \frac{\alpha_s^2 x_B}{Q^2} \int \frac{d\ell_T^2}{\ell_T^2} \int_{z_h}^1 \frac{dz}{z} \overline{T}_{6,C} 2D_{g \rightarrow h}(z_h/z) \\ &\quad \times \frac{-2}{(1-z)z} \frac{C_F(C_F - C_A/2)}{N_c}, \end{aligned} \quad (\text{A-8})$$

$$\begin{aligned} \overline{H}_{6,L(R)}^D &= \frac{\alpha_s^2 x_B}{Q^2} \int \frac{d\ell_T^2}{\ell_T^2} \int_{z_h}^1 \frac{dz}{z} \overline{T}_{6,L(R)} [D_{g \rightarrow h}(z_h/z) + D_{q \rightarrow h}(z_h/z)] \\ &\quad \times \frac{-2}{(1-z)z} \frac{C_F(C_F - C_A/2)}{N_c}, \end{aligned} \quad (\text{A-9})$$

$$\begin{aligned} \overline{T}_{6,C} &= \theta(-y_2^-) \theta(y^- - y_1^-) e^{i(x+x_L)p^+ y^-} \\ &\quad \times (1 - e^{-ix_L p^+ y_2^-}) (1 - e^{-ix_L p^+(y^- - y_1^-)}), \end{aligned} \quad (\text{A-10})$$

$$\overline{T}_{6,L} = -\theta(y_1^- - y_2^-) \theta(y^- - y_1^-) e^{i(x+x_L)p^+ y^-} (1 - e^{-ix_L p^+(y^- - y_1^-)}). \quad (\text{A-11})$$

$$\overline{T}_{6,R} = -\theta(-y_2^-) \theta(y_2^- - y_1^-) e^{i(x+x_L)p^+ y^-} (1 - e^{-ix_L p^+ y_2^-}), \quad (\text{A-12})$$

Note that the central-cut diagram in Fig. 6 corresponds to the interference between  $t$  and  $u$ -channel of the  $q\bar{q} \rightarrow gg$  annihilation processes in Fig. 5. Since the splitting function is symmetric in  $z$  and  $1-z$ , a factor of 2 comes from the fragmentation of both gluons in the central-cut diagram.

The  $s$ -channel of  $q\bar{q} \rightarrow gg$  is shown in Fig. 7 which has only one central-cut. Its contribution to the partonic hard part is,

$$\overline{H}_{7,C}^D = \frac{\alpha_s^2 x_B}{Q^2} \int \frac{d\ell_T^2}{\ell_T^2} \int_{z_h}^1 \frac{dz}{z} \overline{T}_{7,C} 2D_{g \rightarrow h}(z_h/z) \frac{2(z^2 - z + 1)^2 C_F C_A}{z(1-z) N_c}, \quad (\text{A-13})$$

$$\overline{T}_{7,C} = \theta(-y_2^-) \theta(y^- - y_1^-) e^{i(x+x_L)p^+ y^-} e^{-ix_L p^+(y^- - y_1^-)} e^{-ix_L p^+ y_2^-}. \quad (\text{A-14})$$

Note that the splitting function  $2(z^2 - z + 1)^2/z(1-z) = 2[1 - z(1-z)]^2/z(1-z)$  is symmetric in  $z$  and  $1-z$ . Therefore, fragmentation of the two final gluons gives rise to the factor of 2 in front of the gluon fragmentation function.

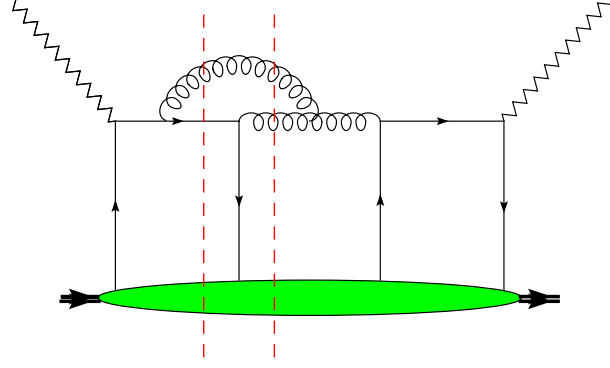

Fig. 8. The interference between  $t$  and  $s$ -channel of  $q\bar{q} \rightarrow gg$  annihilation.

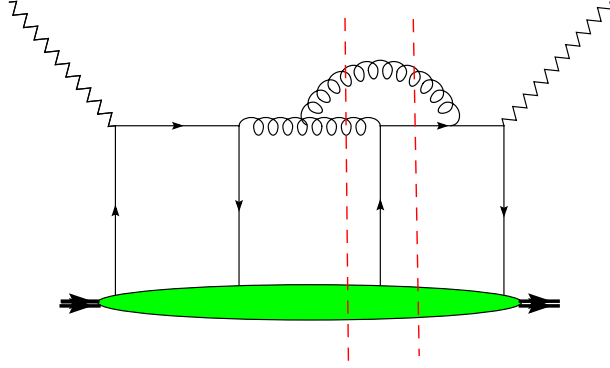

Fig. 9. The complex conjugate of Fig. 8.

The interferences between  $t$  and  $s$ -channel of  $q\bar{q} \rightarrow gg$  processes are shown in Figs. 8 and 9. There are only two possible cuts in these diagrams. The contributions from Fig. 8 are:

$$\begin{aligned} \overline{H}_{8,C}^D &= \frac{\alpha_s^2 x_B}{Q^2} \int \frac{d\ell_T^2}{\ell_T^2} \int_{z_h}^1 \frac{dz}{z} \overline{I}_{8,C} D_{g \rightarrow h}(z_h/z) \\ &\quad \times \left[ 2 \frac{1+z^3}{z(1-z)} + 2 \frac{1+(1-z)^3}{z(1-z)} \right] \frac{C_F C_A}{2N_c}, \end{aligned} \quad (\text{A-15})$$

$$\begin{aligned} \overline{H}_{8,L}^D &= \frac{\alpha_s^2 x_B}{Q^2} \int \frac{d\ell_T^2}{\ell_T^2} \int_{z_h}^1 \frac{dz}{z} \overline{I}_{8,L} \left[ D_{q \rightarrow h}(z_h/z) 2 \frac{1+z^3}{z(1-z)} \right. \\ &\quad \left. + D_{g \rightarrow h}(z_h/z) 2 \frac{1+(1-z)^3}{z(1-z)} \right] \frac{C_F C_A}{2N_c}, \end{aligned} \quad (\text{A-16})$$

$$\begin{aligned} \overline{I}_{8,C} &= \theta(-y_2^-) \theta(y^- - y_1^-) e^{i(x+x_L)p^+ y^-} \\ &\quad \times (1 - e^{-ix_L p^+ y_2^-}) e^{-ix_L p^+(y^- - y_1^-)}, \end{aligned} \quad (\text{A-17})$$

$$\begin{aligned} \overline{I}_{8,L} &= \theta(y_1^- - y_2^-) \theta(y^- - y_1^-) e^{i(x+x_L)p^+ y^-} \\ &\quad \times (e^{-ix_L p^+(y^- - y_2^-)} - e^{-ix_L p^+(y^- - y_1^-)}). \end{aligned} \quad (\text{A-18})$$

Contributions from Fig. 9, which are just the complex conjugate of Fig. 8, are:

$$\begin{aligned} \overline{H}_{9,C}^D &= \frac{\alpha_s^2 x_B}{Q^2} \int \frac{d\ell_T^2}{\ell_T^2} \int_{z_h}^1 \frac{dz}{z} \overline{T}_{9,C} D_{g \rightarrow h}(z_h/z) \\ &\quad \times \left[ 2 \frac{1+z^3}{z(1-z)} + 2 \frac{1+(1-z)^3}{z(1-z)} \right] \frac{C_F C_A}{2N_c}, \end{aligned} \quad (\text{A-19})$$

$$\begin{aligned} \overline{H}_{9,R}^D &= \frac{\alpha_s^2 x_B}{Q^2} \int \frac{d\ell_T^2}{\ell_T^2} \int_{z_h}^1 \frac{dz}{z} \overline{T}_{9,R} \left[ D_{q \rightarrow h}(z_h/z) 2 \frac{1+z^3}{z(1-z)} \right. \\ &\quad \left. + D_{g \rightarrow h}(z_h/z) 2 \frac{1+(1-z)^3}{z(1-z)} \right] \frac{C_F C_A}{2N_c}, \end{aligned} \quad (\text{A-20})$$

$$\begin{aligned} \overline{T}_{9,C} &= \theta(-y_2^-) \theta(y^- - y_1^-) e^{i(x+x_L)p^+ y^-} \\ &\quad \times (1 - e^{-ix_L p^+(y^- - y_1^-)}) e^{-ix_L p^+ y_2^-}, \end{aligned} \quad (\text{A-21})$$

$$\begin{aligned} \overline{T}_{9,R} &= \theta(-y_2^-) \theta(y_2^- - y_1^-) e^{i(x+x_L)p^+ y^-} \\ &\quad \times (1 - e^{-ix_L p^+(y_2^- - y_1^-)}) e^{-ix_L p^+ y_1^-}. \end{aligned} \quad (\text{A-22})$$

One can collect all contributions of the double hard  $q\bar{q} \rightarrow gg$  processes from the central-cut diagrams, which should have the common phase factor

$$\overline{I}_C = \theta(-y_2^-) \theta(y^- - y_1^-) e^{ix p^+ y^-} e^{-ix_L p^+(y_2^- - y_1^-)}, \quad (\text{A-23})$$

and obtain the total effective splitting function in the hard partonic part,

$$\begin{aligned} \frac{C_F}{N_c} P_{q\bar{q} \rightarrow gg}(z) &= \frac{2}{z(1-z)} \frac{1}{N_c} \{ C_F^2 [1+z^2+1+(1-z)^2] - 2C_F(C_F - C_A/2) \\ &\quad + 2C_F C_A (1-z+z^2)^2 - C_F C_A [1+z^3+1+(1-z)^3] \} \\ &= \frac{C_F}{N_c} \left[ 2C_F \frac{z^2+(1-z)^2}{z(1-z)} - 2C_A [z^2+(1-z)^2] \right]. \end{aligned} \quad (\text{A-24})$$

We will find later in Appendix A-3 that the above result can also be obtained from the total matrix elements squared for  $q\bar{q} \rightarrow gg$  annihilation.

We now consider the annihilation processes  $q\bar{q} \rightarrow q_i \bar{q}_i$  with  $q_i \neq q$ . There is only the  $s$ -channel process with one central-cut diagram as shown in Fig. 10. Its contribution to the hard part is

$$\overline{H}_{10,C}^D = \frac{\alpha_s^2 x_B}{Q^2} \int \frac{d\ell_T^2}{\ell_T^2} \int_{z_h}^1 \frac{dz}{z} \overline{T}_{10,C} \sum_{q_i \neq q} [D_{q_i \rightarrow h}(z_h/z) + D_{\bar{q}_i \rightarrow h}(z_h/z)]$$

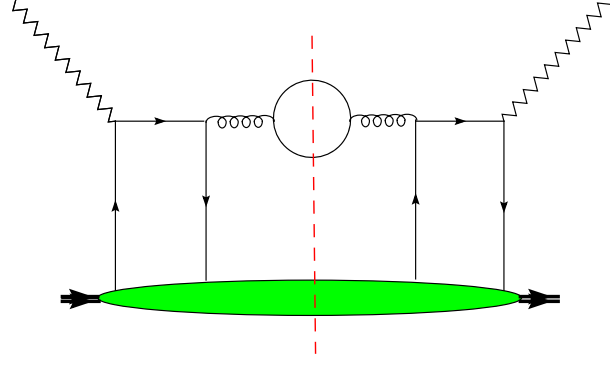

Fig. 10.  $s$ -channel  $q\bar{q} \rightarrow q_i\bar{q}_i$  annihilation.

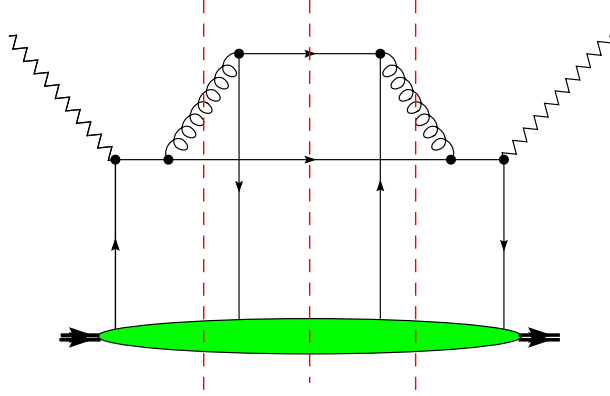

Fig. 11.  $t$ -channel  $qq_i(\bar{q}_i) \rightarrow qq_i(\bar{q}_i)$  scattering.

$$\times [z^2 + (1-z)^2] \frac{C_F}{N_c}, \quad (\text{A-25})$$

$$\bar{T}_{10,C} = \theta(-y_2^-) \theta(y^- - y_1^-) e^{i(x+x_L)p^+y^-} e^{-ix_L p^+(y^- - y_1^-)} e^{-ix_L p^+ y_2^-}. \quad (\text{A-26})$$

Here we define the effective splitting function for  $q\bar{q} \rightarrow q_i\bar{q}_i$  annihilation as,

$$\frac{C_F}{N_c} P_{q\bar{q} \rightarrow q_i\bar{q}_i}(z) = \frac{C_F}{N_c} [z^2 + (1-z)^2]. \quad (\text{A-27})$$

Similarly, for  $q\bar{q}_i \rightarrow q\bar{q}_i$  scattering with  $q_i \neq q$ , there is only the  $t$ -channel as shown in Fig. 11. There are, however, three cut diagrams. Their contributions to the partonic hard part are:

$$\begin{aligned} \bar{H}_{11,C}^D &= \frac{\alpha_s^2 x_B}{Q^2} \int \frac{d\ell_T^2}{\ell_T^2} \int_{z_h}^1 \frac{dz}{z} \bar{T}_{11,C} \\ &\times \left[ D_{q \rightarrow h}(z_h/z) \frac{1+z^2}{(1-z)^2} + D_{\bar{q}_i \rightarrow h}(z_h/z) \frac{1+(1-z)^2}{z^2} \right] \frac{C_F}{N_c}, \end{aligned} \quad (\text{A-28})$$

$$\begin{aligned} \overline{H}_{11,L(R)}^D &= \frac{\alpha_s^2 x_B}{Q^2} \int \frac{d\ell_T^2}{\ell_T^2} \int_{z_h}^1 \frac{dz}{z} \overline{T}_{11,L(R)} \\ &\times \left[ D_{q \rightarrow h}(z_h/z) \frac{1+z^2}{(1-z)^2} + D_{g \rightarrow h}(z_h/z) \frac{1+(1-z)^2}{z^2} \right] \frac{C_F}{N_c}, \end{aligned} \quad (\text{A-29})$$

$$\begin{aligned} \overline{T}_{11,C} &= \theta(-y_2^-) \theta(y^- - y_1^-) e^{i(x+x_L)p^+ y^-} \\ &\times (1 - e^{-ix_L p^+ y_2^-}) (1 - e^{-ix_L p^+ (y^- - y_1^-)}), \end{aligned} \quad (\text{A-30})$$

$$\overline{T}_{11,L} = -\theta(y_1^- - y_2^-) \theta(y^- - y_1^-) e^{i(x+x_L)p^+ y^-} (1 - e^{-ix_L p^+ (y^- - y_1^-)}), \quad (\text{A-31})$$

$$\overline{T}_{11,R} = -\theta(-y_2^-) \theta(y_2^- - y_1^-) e^{i(x+x_L)p^+ y^-} (1 - e^{-ix_L p^+ y_2^-}). \quad (\text{A-32})$$

The twist-four two-parton correlation matrix element associated with the above quark-antiquark scattering is the quark-antiquark correlator,

$$\begin{aligned} T_{q\bar{q}_i}^A(x, x_L) &\propto e^{ixp^+ y^- - ix_L p^+ (y_2^- - y_1^-)} \\ &\times \langle A | \bar{\psi}_q(0) \frac{\gamma^+}{2} \psi_q(y^-) \bar{\psi}_{q_i}(y_1^-) \frac{\gamma^+}{2} \psi_{q_i}(y_2^-) | A \rangle, \end{aligned} \quad (\text{A-33})$$

and one should sum over all possible  $q_i \neq q$  flavors. Note that in the above matrix element, the momentum flow for the antiquark ( $\bar{q}_i$ ) is opposite to that of the quark ( $q$ ) fields.

For quark-quark scattering,  $qq_i \rightarrow qq_i$ , the hard part is essentially the same. The only difference is the associated matrix element for the quark-quark correlator which is obtained from that of the quark-antiquark correlator via the exchange  $\psi_{q_i}(y_2) \rightarrow \bar{\psi}_{q_i}(y_2)$  and  $\bar{\psi}_{q_i}(y_1) \rightarrow \psi_{q_i}(y_1)$ ,

$$\begin{aligned} T_{qq_i}^A(x, x_L) &\propto e^{ixp^+ y^- + ix_L p^+ (y_1^- - y_2^-)} \\ &\times \langle A | \bar{\psi}_q(0) \frac{\gamma^+}{2} \psi_q(y^-) \bar{\psi}_{q_i}(y_2^-) \frac{\gamma^+}{2} \psi_{q_i}(y_1^-) | A \rangle. \end{aligned} \quad (\text{A-34})$$

Note that the momentum flows of the two quarks ( $q$  and  $q_i$ ) point in the same direction.

The effective splitting function of this scattering process is defined through the fragmentation of the quark in the central-cut diagram,

$$\frac{C_F}{N_c} P_{qq_i(\bar{q}_i) \rightarrow qq_i(\bar{q}_i)}(z) = \frac{C_F}{N_c} \frac{1+z^2}{(1-z)^2}. \quad (\text{A-35})$$

For annihilation  $q\bar{q} \rightarrow q\bar{q}$  into identical quark and antiquark pairs, in addition to the  $s$ -channel (Fig. 10 for  $q_i = q$ ) and  $t$ -channel (Fig. 11 for  $q_i = \bar{q}$ ), one has also to consider the interference between  $s$  and  $t$ -channel amplitudes as shown in Figs. 12 and 13, each having two cuts. Their contributions to the hard partonic parts are, respectively:

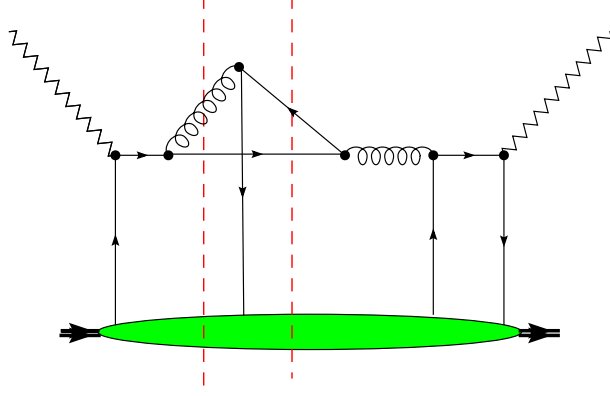

Fig. 12. Interference between  $s$  and  $t$ -channel of  $q\bar{q} \rightarrow q\bar{q}$  scattering

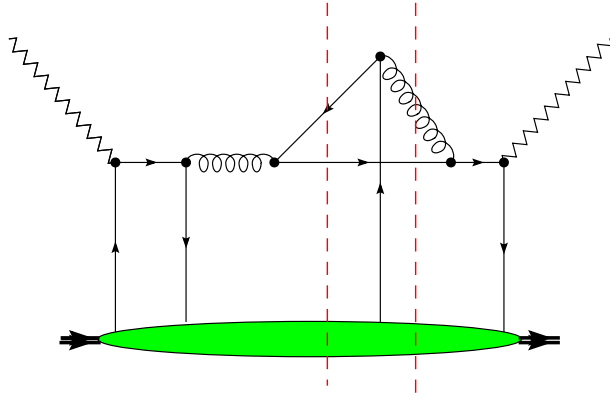

Fig. 13. The complex conjugate of Fig. 12.

$$\begin{aligned} \overline{H}_{12,C}^D &= \frac{\alpha_s^2 x_B}{Q^2} \int \frac{d\ell_T^2}{\ell_T^2} \int_{z_h}^1 \frac{dz}{z} \overline{I}_{12,C} \left[ D_{q \rightarrow h}(z_h/z) \frac{2z^2}{(1-z)} \right. \\ &\quad \left. + D_{\bar{q} \rightarrow h}(z_h/z) \frac{2(1-z)^2}{z} \right] \frac{C_F(C_F - C_A/2)}{N_c}, \end{aligned} \quad (\text{A-36})$$

$$\begin{aligned} \overline{H}_{12,L}^D &= \frac{\alpha_s^2 x_B}{Q^2} \int \frac{d\ell_T^2}{\ell_T^2} \int_{z_h}^1 \frac{dz}{z} \overline{I}_{12,L} \left[ D_{q \rightarrow h}(z_h/z) \frac{2z^2}{(1-z)} \right. \\ &\quad \left. + D_{g \rightarrow h}(z_h/z) \frac{2(1-z)^2}{z} \right] \frac{C_F(C_F - C_A/2)}{N_c}, \end{aligned} \quad (\text{A-37})$$

$$\begin{aligned} \overline{I}_{12,C} &= \theta(-y_2^-) \theta(y^- - y_1^-) e^{i(x+x_L)p^+ y^-} \\ &\quad \times (1 - e^{-ix_L p^+ y_2^-}) e^{-ix_L p^+(y^- - y_1^-)}, \end{aligned} \quad (\text{A-38})$$

$$\begin{aligned} \overline{I}_{12,L} &= \theta(y_1^- - y_2^-) \theta(y^- - y_1^-) e^{i(x+x_L)p^+ y^-} \\ &\quad \times (e^{-ix_L p^+(y^- - y_2^-)} - e^{-ix_L p^+(y^- - y_1^-)}); \end{aligned} \quad (\text{A-39})$$

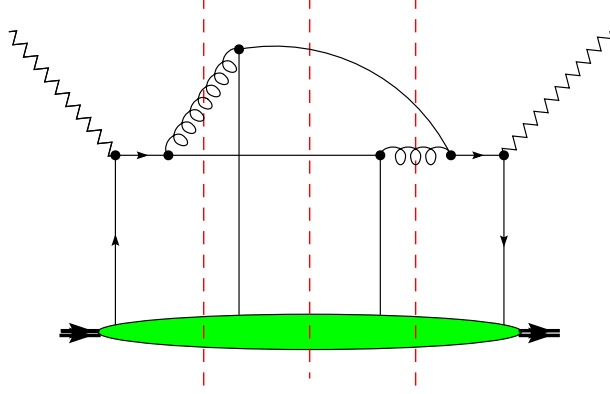

Fig. 14. The interference between  $t$  and  $u$ -channel of identical quark-quark scattering  $qq \rightarrow qq$ .

$$\begin{aligned} \overline{H}_{13,C}^D = \frac{\alpha_s^2 x_B}{Q^2} \int \frac{d\ell_T^2}{\ell_T^2} \int_{z_h}^1 \frac{dz}{z} \overline{T}_{13,C} \left[ D_{q \rightarrow h}(z_h/z) \frac{2z^2}{(1-z)} \right. \\ \left. + D_{\bar{q} \rightarrow h}(z_h/z) \frac{2(1-z)^2}{z} \right] \frac{C_F(C_F - C_A/2)}{N_c}, \end{aligned} \quad (\text{A-40})$$

$$\begin{aligned} \overline{H}_{13,R}^D = \frac{\alpha_s^2 x_B}{Q^2} \int \frac{d\ell_T^2}{\ell_T^2} \int_{z_h}^1 \frac{dz}{z} \overline{T}_{13,R} \left[ D_{q \rightarrow h}(z_h/z) \frac{2z^2}{(1-z)} \right. \\ \left. + D_{g \rightarrow h}(z_h/z) \frac{2(1-z)^2}{z} \right] \frac{C_F(C_F - C_A/2)}{N_c}, \end{aligned} \quad (\text{A-41})$$

$$\begin{aligned} \overline{T}_{13,C} = \theta(-y_2^-) \theta(y^- - y_1^-) e^{i(x+x_L)p^+ y^-} \\ \times (1 - e^{-ix_L p^+(y^- - y_1^-)}) e^{-ix_L p^+ y_2^-}, \end{aligned} \quad (\text{A-42})$$

$$\begin{aligned} \overline{T}_{13,R} = \theta(-y_2^-) \theta(y_2^- - y_1^-) e^{i(x+x_L)p^+ y^-} \\ \times (e^{-ix_L p^+ y_1^-} - e^{-ix_L p^+ y_2^-}). \end{aligned} \quad (\text{A-43})$$

One can again collect contributions from the central-cut diagrams of the double scattering processes in Figs. 10, 11 12 and 13 and obtain the total effective splitting function for  $q\bar{q} \rightarrow q\bar{q}$ ,

$$\begin{aligned} \frac{C_F}{N_c} P_{q\bar{q} \rightarrow q\bar{q}}(z) = \frac{C_F}{N_c} [z^2 + (1-z)^2] + \frac{C_F}{N_c} \frac{1+z^2}{(1-z)^2} - \frac{C_F(C_F - C_A/2)}{N_c} \frac{4z^2}{1-z} \\ = \frac{C_F}{N_c} \left[ z^2 + (1-z)^2 + \frac{1+z^2}{(1-z)^2} + \frac{1}{N_c} \frac{2z^2}{1-z} \right]. \end{aligned} \quad (\text{A-44})$$

Here we have used  $C_F - C_A/2 = -1/2N_c$ . For antiquark fragmentation,  $P_{q\bar{q} \rightarrow \bar{q}q}(z) = P_{q\bar{q} \rightarrow q\bar{q}}(1-z)$ . One can also obtain the above result from  $q\bar{q} \rightarrow q\bar{q}$  scattering matrix squared as shown in Appendix A-3.

Similarly, for scattering of identical quarks  $qq \rightarrow qq$ , one should set  $q_i = q$  in Fig. 11[in Eq. (A-28)]. In addition, one should also include interference between  $t$  and  $u$ -channel



of the scattering as shown in Fig. 14. The contributions from such interference diagram are,

$$\begin{aligned} \overline{H}_{14,C}^D &= \frac{\alpha_s^2 x_B}{Q^2} \int \frac{d\ell_T^2}{\ell_T^2} \int_{z_h}^1 \frac{dz}{z} \overline{T}_{14,C} \\ &\times 2D_{q \rightarrow h}(z_h/z) \frac{2}{z(1-z)} \frac{C_F(C_F - C_A/2)}{N_c}, \end{aligned} \quad (\text{A-45})$$

$$\begin{aligned} \overline{H}_{14,L(R)}^D &= \frac{\alpha_s^2 x_B}{Q^2} \int \frac{d\ell_T^2}{\ell_T^2} \int_{z_h}^1 \frac{dz}{z} \overline{T}_{14,L(R)} \\ &\times [D_{q \rightarrow h}(z_h/z) + D_{g \rightarrow h}(z_h/z)] \frac{2}{z(1-z)} \frac{C_F(C_F - C_A/2)}{N_c}, \end{aligned} \quad (\text{A-46})$$

$$\begin{aligned} \overline{T}_{14,C} &= \theta(-y_2^-) \theta(y^- - y_1^-) e^{i(x+x_L)p^+ y^-} \\ &\times (1 - e^{-ix_L p^+ y_2^-}) (1 - e^{-ix_L p^+ (y^- - y_1^-)}), \end{aligned} \quad (\text{A-47})$$

$$\overline{T}_{14,L} = -\theta(y_1^- - y_2^-) \theta(y^- - y_1^-) e^{i(x+x_L)p^+ y^-} (1 - e^{-ix_L p^+ (y^- - y_1^-)}), \quad (\text{A-48})$$

$$\overline{T}_{14,R} = -\theta(-y_2^-) \theta(y_2^- - y_1^-) e^{i(x+x_L)p^+ y^-} (1 - e^{-ix_L p^+ y_2^-}). \quad (\text{A-49})$$

Note again that the fragmentation of both quarks contributes to the factor 2 in Eq. (A-45) since the splitting function is symmetric in  $z$  and  $1-z$ . The twist-four two-quark correlation matrix element associated with  $qq \rightarrow qq$  scattering is  $T_{qq}^A(x, x_L)$  as compared to  $T_{q\bar{q}}^A(x, x_L)$  for quark-antiquark annihilation processes.

We can sum contributions from the double hard scattering in all the central-cut diagrams in Figs. 11 and 14 and obtain the total effective splitting function for  $qq \rightarrow qq$  processes,

$$\begin{aligned} \frac{C_F}{N_c} P_{qq \rightarrow qq}(z) &= \frac{C_F}{N_c} \left[ \frac{1+z^2}{(1-z)^2} + \frac{1+(1-z)^2}{z^2} \right] + \frac{C_F(C_F - C_A/2)}{N_c} \frac{4}{z(1-z)} \\ &= \frac{C_F}{N_c} \left[ \frac{1+z^2}{(1-z)^2} + \frac{1+(1-z)^2}{z^2} - \frac{1}{N_c} \frac{2}{z(1-z)} \right]. \end{aligned} \quad (\text{A-50})$$

There are two remaining cut diagrams that contribute to the quark-antiquark annihilation at the order of  $\mathcal{O}(\alpha_s^2)$  as shown in Figs. 15 and 16. Their contributions are:

$$\begin{aligned} \overline{H}_{15,L}^D &= \frac{\alpha_s^2 x_B}{Q^2} \int \frac{d\ell_T^2}{\ell_T^2} \int_{z_h}^1 \frac{dz}{z} \overline{T}_{15,L} \\ &\times \left[ D_{q \rightarrow h}(z_h/z) 2 \frac{1+z^2}{1-z} + D_{g \rightarrow h}(z_h/z) 2 \frac{1+(1-z)^2}{z} \right] \frac{C_F^2}{N_c}, \end{aligned} \quad (\text{A-51})$$

$$\overline{T}_{15,L} = -\theta(y_1^- - y_2^-) \theta(y^- - y_1^-) e^{i(x+x_L)p^+ y^-} e^{-ix_L p^+ (y^- - y_2^-)}, \quad (\text{A-52})$$

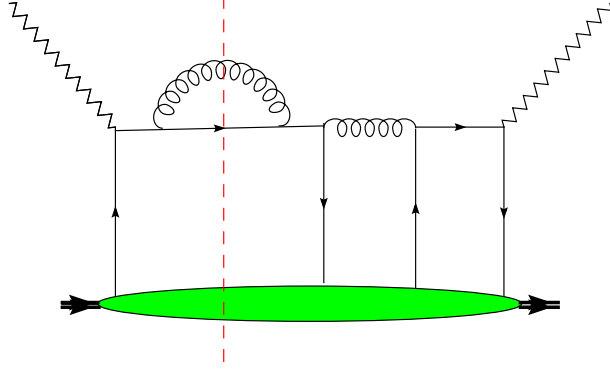

Fig. 15. Interference between final-state gluon radiation from single and triple-quark scattering.

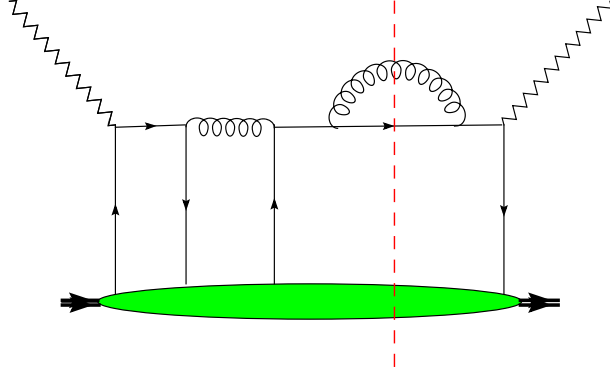

Fig. 16. The complex conjugate of Fig. 15.

$$\begin{aligned} \bar{H}_{16,R}^D &= \frac{\alpha_s^2 x_B}{Q^2} \int \frac{d\ell_T^2}{\ell_T^2} \int_{z_h}^1 \frac{dz}{z} \bar{I}_{16,R} \\ &\times \left[ D_{q \rightarrow h}(z_h/z) 2 \frac{1+z^2}{1-z} + D_{g \rightarrow h}(z_h/z) 2 \frac{1+(1-z)^2}{z} \right] \frac{C_F^2}{N_c}, \end{aligned} \quad (\text{A-53})$$

$$\bar{I}_{16,R} = -\theta(-y_2^-) \theta(y_2^- - y_1^-) e^{i(x+x_L)p^+ y^-} e^{-ix_L p^+ y_1^-}. \quad (\text{A-54})$$

## A-2 Effective splitting functions

In this Appendix, we list the effective splitting functions associated with each process  $qa \rightarrow b$  and the double-hard ( $HI$ ), hard-soft ( $SI$ ) or their interferences ( $I$ ,  $I2$ ) according to Eq. (73).

$$\begin{aligned} P_{qq_i(\bar{q}_i) \rightarrow q_i(\bar{q}_i)}^{(HI)}(z) &= \frac{1+(1-z)^2}{z^2}, & P_{qq_i(\bar{q}_i) \rightarrow q}^{(HI)}(z) &= \frac{1+z^2}{(1-z)^2}, \\ P_{qq_i(\bar{q}_i) \rightarrow q_i(\bar{q}_i)}^{(SI)}(z) &= \frac{1+(1-z)^2}{z^2}, & P_{qq_i(\bar{q}_i) \rightarrow g}^{(SI)}(z) &= -\frac{1+(1-z)^2}{z^2} \end{aligned} \quad (\text{A-55})$$

$$\begin{aligned}
P_{q\bar{q}\rightarrow q_i}^{(HI)}(z) &= P_{q\bar{q}\rightarrow \bar{q}_i}^{(HI)}(z) = z^2 + (1-z)^2, \\
P_{q\bar{q}\rightarrow q_i}^{(I)}(z) &= P_{q\bar{q}\rightarrow \bar{q}_i}^{(I)}(z) = z^2 + (1-z)^2,
\end{aligned} \tag{A-56}$$

$$\begin{aligned}
P_{qq\rightarrow q}^{(HI)}(z) &= \frac{1+(1-z)^2}{z^2} + \frac{1+z^2}{(1-z)^2} - \frac{2}{N_c} \frac{1}{z(1-z)}, \\
P_{qq\rightarrow g}^{(SI)}(z) &= -P_{qq\rightarrow q}^{(SI)}(z), \\
P_{qq\rightarrow q}^{(SI)}(z) &= \frac{1+(1-z)^2}{z^2} - \frac{1}{N_c} \frac{1}{z(1-z)},
\end{aligned} \tag{A-57}$$

$$\begin{aligned}
P_{q\bar{q}\rightarrow q}^{(HI)}(z) &= z^2 + (1-z)^2 + \frac{1+z^2}{(1-z)^2} + \frac{2}{N_c} \frac{z^2}{1-z}, \\
P_{q\bar{q}\rightarrow \bar{q}}^{(HI)}(z) &= P_{q\bar{q}\rightarrow q}^{(HI)}(1-z), \\
P_{q\bar{q}\rightarrow g}^{(HI)}(z) &= 2C_F \frac{z^2 + (1-z)^2}{z(1-z)} - 2C_A [z^2 + (1-z)^2],
\end{aligned} \tag{A-58}$$

$$\begin{aligned}
P_{q\bar{q}\rightarrow q}^{(SI)}(z) &= - \left[ \frac{C_A}{z(1-z)} + 2C_F \frac{z}{1-z} \right], \\
P_{q\bar{q}\rightarrow \bar{q}}^{(SI)}(z) &= \frac{1+(1-z)^2}{z^2}, \\
P_{q\bar{q}\rightarrow g}^{(SI)}(z) &= \frac{C_A}{z(1-z)} + 2C_F \frac{z}{1-z} - \frac{1+(1-z)^2}{z^2}
\end{aligned} \tag{A-59}$$

$$\begin{aligned}
P_{q\bar{q}\rightarrow q}^{(I)}(z) &= z^2 + (1-z)^2 - \frac{C_A}{z(1-z)} - 2C_F \frac{z^2}{1-z}, \\
P_{q\bar{q}\rightarrow \bar{q}}^{(I)}(z) &= z^2 + (1-z)^2, \\
P_{q\bar{q}\rightarrow g}^{(I)}(z) &= C_A \frac{4(1-z+z^2)^2 - 1}{z(1-z)} - 2C_F \frac{(1-z)^2}{z},
\end{aligned} \tag{A-60}$$

$$P_{q\bar{q}\rightarrow q}^{(I2)}(z) = \frac{C_A}{z(1-z)} - \frac{2C_F}{1-z}, \quad P_{q\bar{q}\rightarrow g}^{(I2)}(z) = \frac{C_A}{z(1-z)} - \frac{2C_F}{z}. \tag{A-61}$$

The non-singlet splitting functions for  $q\bar{q} \rightarrow b$ , defined as

$$\Delta P_{q\bar{q}\rightarrow b}^{N(i)}(z) \equiv P_{q\bar{q}\rightarrow b}^{(i)}(z) - P_{qq\rightarrow b}^{(i)}(z), \tag{A-62}$$

are listed as below:

$$\Delta P_{q\bar{q}\rightarrow q_i(\bar{q}_i)}^{N(HI)}(z) = P_{q\bar{q}\rightarrow q_i(\bar{q}_i)}^{(HI)}(z), \quad \Delta P_{q\bar{q}\rightarrow q_i(\bar{q}_i)}^{N(I)}(z) = P_{q\bar{q}\rightarrow q_i(\bar{q}_i)}^{(I)}(z), \tag{A-63}$$

$$\begin{aligned}
\Delta P_{q\bar{q}\rightarrow q}^{N(HI)}(z) &= - \frac{(1-z^2)(1+z^2+(1-z)^2)}{z^2} + \frac{2}{N_c} \frac{1+z^3}{z(1-z)}, \\
\Delta P_{q\bar{q}\rightarrow \bar{q}}^{N(HI)}(z) &= P_{q\bar{q}\rightarrow \bar{q}}^{(HI)}(z), \quad \Delta P_{q\bar{q}\rightarrow g}^{N(HI)}(z) = P_{q\bar{q}\rightarrow g}^{(HI)}(z),
\end{aligned} \tag{A-64}$$

$$\begin{aligned}
\Delta P_{q\bar{q}\rightarrow q}^{N(SI)}(z) &= - \left[ 2C_F \frac{1+z^2}{1-z} + \frac{1+(1-z)^2}{z^2} \right], \\
\Delta P_{q\bar{q}\rightarrow\bar{q}}^{N(SI)}(z) &= P_{q\bar{q}\rightarrow\bar{q}}^{(SI)}(z) \\
\Delta P_{q\bar{q}\rightarrow g}^{N(SI)}(z) &= 2C_F \frac{1+z^2}{1-z} + \frac{2}{N_c} \frac{1}{z(1-z)} - 2 \frac{1+(1-z)^2}{z^2}
\end{aligned} \tag{A-65}$$

$$\Delta P_{q\bar{q}\rightarrow b}^{N(I)}(z) = P_{q\bar{q}\rightarrow b}^{(I)}(z), \quad \Delta P_{q\bar{q}\rightarrow b}^{N(I2)}(z) = P_{q\bar{q}\rightarrow b}^{(I2)}(z) \quad (b = q, \bar{q}, g) \tag{A-66}$$

### A-3 Alternative calculations of central-cut diagrams

As a cross-check of the hard partonic parts calculated from different cut diagrams in Appendix A-1, we provide an alternative calculation of all the central-cut diagrams, which correspond to quark-quark (antiquark) scattering.

Considering a parton ( $a$ ) with momentum  $q$  scattering with another parton ( $b$ ) that carries a fractional momentum  $xp$ ,  $a(q) + b(xp) \rightarrow c(\ell) + d(p')$ , the cross section can be written as

$$\begin{aligned}
d\sigma_{ab} &= \frac{g^4}{2\hat{s}} |M|_{ab\rightarrow cd}^2(\hat{t}/\hat{s}, \hat{u}/\hat{s}) \frac{d^3\ell}{(2\pi)^3 2\ell_0} 2\pi \delta[(p+q-\ell)^2] \\
&= \frac{g^4}{(4\pi)^2} |M|_{ab\rightarrow cd}^2(\hat{t}/\hat{s}, \hat{u}/\hat{s}) \frac{\pi}{\hat{s}^2} \frac{dz}{z(1-z)} d\ell_T^2 \delta\left(1 - \frac{x_L}{x}\right),
\end{aligned} \tag{A-67}$$

where  $q = [0, q^-, 0]$  and  $p = [xp^+, 0, 0]$  are momenta of the initial partons and

$$\ell = \left[ \frac{\ell_T^2}{2zq^-}, zq^-, \vec{\ell}_T \right] \tag{A-68}$$

is the momentum of one of the final partons. With the given kinematics, the on-shell condition in the cross section can be recast as

$$(xp + q - \ell)^2 = 2(1-z)xp^+q^- \left(1 - \frac{x_L}{x}\right), \quad x_L = \frac{\ell_T^2}{2z(1-z)p^+q^-}. \tag{A-69}$$

The Mandelstam variables of the collision are,

$$\begin{aligned}
\hat{s} &= (q + xp)^2 = 2xp^+q^- = \frac{\ell_T^2}{z(1-z)}, \quad \hat{u} = (\ell - xp)^2 = -z\hat{s}, \\
\hat{t} &= (\ell - q)^2 = -(1-z)\frac{x_L}{x}\hat{s} = -(1-z)\hat{s},
\end{aligned} \tag{A-70}$$

where we have used the on-shell condition  $x = x_L$ .

With Eq. (A-67) and parton distribution functions  $f_b^N(x)$ , one can obtain the parton-nucleon cross section,

$$\begin{aligned}
d\sigma_{aN} &= \sum_b d\sigma_{ab} f_b^N(x) dx \\
&= \sum_b f_b^N(x_L) x_L |M|_{ab \rightarrow cd}^2(\hat{t}/\hat{s}, \hat{u}/\hat{s}) \frac{\pi\alpha_s^2}{\hat{s}^2} \frac{dz}{z(1-z)} d\ell_T^2 \\
&= \sum_b f_b^N(x_L) \frac{\pi\alpha_s^2}{s} C_0 P_{ab \rightarrow cd}(z) dz \frac{d\ell_T^2}{\ell_T^2}, \tag{A-71}
\end{aligned}$$

where  $s = 2p^+q^-$  is the center-of-mass energy for  $aN$  collision,  $C_0$  is some common color factor in the scattering matrix elements and

$$P_{ab \rightarrow cd}(z) = (1/C_0) |M|_{ab \rightarrow cd}^2(\hat{t}/\hat{s}, \hat{u}/\hat{s}) \tag{A-72}$$

is what we have defined as the effective splitting function for the corresponding processes. One can therefore easily obtain these effective splitting functions from the corresponding matrix elements for elementary parton-parton scattering [39]. We will list them in the following. A common color factor for all quark-quark(antiquark) scattering is  $C_0 = C_F/N_c$ .

$q\bar{q} \rightarrow q_i\bar{q}_i$  annihilation:

$$\begin{aligned}
|M|_{q\bar{q} \rightarrow q_i\bar{q}_i}^2 &= \frac{C_F}{N_c} \frac{\hat{t}^2 + \hat{u}^2}{\hat{s}^2}, \\
P_{q\bar{q} \rightarrow q_i\bar{q}_i}(z) &= z^2 + (1-z)^2. \tag{A-73}
\end{aligned}$$

$q\bar{q} \rightarrow q\bar{q}$  annihilation:

$$\begin{aligned}
|M|_{q\bar{q} \rightarrow q\bar{q}}^2 &= \frac{C_F}{N_c} \left[ \frac{\hat{u}^2 + \hat{s}^2}{\hat{t}^2} + \frac{\hat{u}^2 + \hat{t}^2}{\hat{s}^2} - \frac{1}{N_c} \frac{2\hat{u}^2}{\hat{s}\hat{t}} \right], \\
P_{q\bar{q} \rightarrow q\bar{q}}(z) &= \frac{1+z^2}{(1-z)^2} + z^2 + (1-z)^2 + \frac{2}{N_c} \frac{z^2}{1-z}. \tag{A-74}
\end{aligned}$$

$q\bar{q} \rightarrow gg$  annihilation:

$$|M|_{q\bar{q} \rightarrow gg}^2 = \frac{C_F}{N_c} \left[ 2C_F \left( \frac{\hat{u}}{\hat{t}} + \frac{\hat{t}}{\hat{u}} \right) - 2C_A \frac{\hat{u}^2 + \hat{t}^2}{\hat{s}^2} \right],$$

$$P_{q\bar{q}\rightarrow gg}(z) = 2C_F \frac{z^2 + (1-z)^2}{z(1-z)} - 2C_A(z^2 + (1-z)^2). \quad (\text{A-75})$$

$qq_i(\bar{q}_i) \rightarrow qq_i(\bar{q}_i)$  scattering:

$$\begin{aligned} |M|_{qq_i(\bar{q}_i)\rightarrow qq_i(\bar{q}_i)}^2 &= \frac{C_F}{N_c} \frac{\hat{u}^2 + \hat{s}^2}{\hat{t}^2} \\ P_{qq_i(\bar{q}_i)\rightarrow qq_i(\bar{q}_i)}(z) &= \frac{1+z^2}{(1-z)^2}. \end{aligned} \quad (\text{A-76})$$

$qq \rightarrow qq$  scattering:

$$\begin{aligned} |M|_{qq\rightarrow qq}^2 &= \frac{C_F}{N_c} \left[ \frac{\hat{u}^2 + \hat{s}^2}{\hat{t}^2} + \frac{\hat{s}^2 + \hat{t}^2}{\hat{u}^2} - \frac{1}{N_c} \frac{2\hat{s}^2}{\hat{t}\hat{u}} \right], \\ P_{qq\rightarrow qq}(z) &= \frac{1+z^2}{(1-z)^2} + \frac{1+(1-z)^2}{z^2} - \frac{2}{N_c} \frac{1}{z(1-z)}. \end{aligned} \quad (\text{A-77})$$

For quark-gluon Compton scattering, the relevant gluon distribution function is  $x_L G_N(x_L)$ . One can therefore rewrite contribution from  $qg \rightarrow qg$  to Eq. (A-71) as,

$$\begin{aligned} d\sigma_{qN} &= x_L G_N(x_L) \pi \alpha_s^2 z(1-z) |M|_{qg\rightarrow qg}^2(\hat{t}/\hat{s}, \hat{u}/\hat{s}) dz \frac{d\ell_T^2}{\ell_T^4} \\ &\equiv x_L G_N(x_L) \pi \alpha_s^2 \frac{C_F}{N_c} P_{qg\rightarrow qg}(z) dz \frac{d\ell_T^2}{\ell_T^4}. \end{aligned} \quad (\text{A-78})$$

We have then for  $qg \rightarrow qg$  scattering,

$$\begin{aligned} |M|_{qg\rightarrow qg}^2 &= \frac{C_A}{N_c} \frac{\hat{s}^2 + \hat{u}^2}{\hat{t}^2} - \frac{C_F}{N_c} \frac{\hat{u}^2 + \hat{s}^2}{\hat{u}\hat{s}} \\ P_{qg\rightarrow qg}(z) &= z(1-z) \left[ \frac{C_A}{C_F} \frac{1+z^2}{(1-z)^2} + \frac{1+z^2}{z} \right]. \end{aligned} \quad (\text{A-79})$$

Comparing this result with that in Ref. [18] for the quark-gluon rescattering, we can see that they agree in the limit  $1-z \rightarrow 0$ . This is a consequence of the collinear approximation employed in Ref. [18] in the calculation of the hard partonic part in quark-gluon rescattering.

We can also extend this calculation to the case of gluon-nucleon scattering. One can use Eq. (A-71) to define the splitting function for  $gq \rightarrow gq$  scattering,

$$\begin{aligned}
|M|_{gg \rightarrow gq}^2 &= \frac{C_A}{N_c} \frac{\hat{s}^2 + \hat{t}^2}{\hat{u}^2} - \frac{C_F}{N_c} \frac{\hat{t}^2 + \hat{s}^2}{\hat{t}\hat{s}} \\
P_{gq \rightarrow gq}(z) &= z(1-z) \left[ \frac{C_A}{N_c} \frac{1 + (1-z)^2}{z^2} + \frac{C_F}{N_c} \frac{1 + (1-z)^2}{(1-z)} \right].
\end{aligned} \tag{A-80}$$

Here for gluon-parton scattering, there is no common color factor.

$gg \rightarrow q\bar{q}$  annihilation,

$$\begin{aligned}
|M|_{gg \rightarrow q\bar{q}}^2 &= \frac{1}{2N_c} \frac{\hat{t}^2 + \hat{u}^2}{\hat{t}\hat{u}} - \frac{1}{2C_F} \frac{\hat{t}^2 + \hat{u}^2}{\hat{s}^2} \\
P_{gg \rightarrow q\bar{q}}(z) &= z(1-z) \left\{ \frac{1}{2N_c} \frac{z^2 + (1-z)^2}{z(1-z)} - \frac{1}{2C_F} [z^2 + (1-z)^2] \right\}.
\end{aligned} \tag{A-81}$$

$gg \rightarrow gg$  scattering

$$\begin{aligned}
|M|_{gg \rightarrow gg}^2 &= 2 \frac{C_A}{C_F} \left[ 3 - \frac{\hat{t}\hat{u}}{\hat{s}^2} - \frac{\hat{u}\hat{s}}{\hat{t}^2} - \frac{\hat{t}\hat{s}}{\hat{u}^2} \right] \\
P_{gg \rightarrow gg}(z) &= 2 \frac{C_A}{C_F} \frac{(1-z+z^2)^3}{z(1-z)}.
\end{aligned} \tag{A-82}$$

One can use this technique to extend the study of modified fragmentation functions to propagating gluons. Since the modification is dominated by quark-gluon and gluon-gluon scattering, comparing the effective splitting functions,

$$\frac{C_F}{N_c} P_{qg \rightarrow qg}(z) \approx \frac{C_A}{N_c} \frac{2}{1-z}, \tag{A-83}$$

$$P_{gg \rightarrow gg}(z) \approx \frac{2C_A}{C_F} \frac{1}{1-z}, \tag{A-84}$$

in the limit  $z \rightarrow 1$ , one can conclude that a gluon's radiative energy loss is larger than a quark by a factor of  $N_c/C_F = C_A/C_F = 9/4$ . We will leave the complete derivation of medium modification of gluon fragmentations to a future publication.

## References

- [1] K. Adcox *et al.*, [PHENIX Collaboration], Phys. Rev. Lett. **88**, 022301 (2002).
- [2] C. Adler *et al.*, [STAR Collaboration], Phys. Rev. Lett. **89** 202301 (2002).
- [3] C. Adler *et al.*, [STAR Collaboration], Phys. Rev. Lett. **90**, 082302 (2003).

- [4] M. Gyulassy and L. McLerran, Nucl. Phys. A **750**, 30 (2005).
- [5] P. Jacobs and X. N. Wang, Prog. Part. Nucl. Phys. **54**, 443 (2005).
- [6] J. W. Qiu, [arXiv:hep-ph/0507268].
- [7] J. W. Qiu and G. Sterman, Int. J. Mod. Phys. E **12** (2003) 149.
- [8] X. F. Guo, Phys. Rev. D **58** (1998) 114033.
- [9] X. F. Guo, J. W. Qiu and W. Zhu, Phys. Lett. B **523** (2001) 88.
- [10] R. J. Fries, A. Schäfer, E. Stein and B. Muller, Nucl. Phys. B **582**, 537 (2000).
- [11] J. W. Qiu and X. Zhang, Phys. Lett. B **525** (2002) 265.
- [12] J. W. Qiu and I. Vitev, Phys. Rev. Lett. **93**, 262301 (2004), J. W. Qiu and I. Vitev, Phys. Lett. B **587**, 52 (2004).
- [13] M. Gyulassy and X.-N. Wang, Nucl. Phys. B **420**, 583 (1994); X.-N. Wang, M. Gyulassy and M. Plümer, Phys. Rev. D **51**, 3436 (1995).
- [14] R. Baier *et al.*, Nucl. Phys. B **483**, 291 (1997). Nucl. Phys. B **484**, 265 (1997); Phys. Rev. C **58**, 1706 (1998).
- [15] B. G. Zakharov, JETP Lett. **63**, 952 (1996).
- [16] M. Gyulassy, P. Lévai and I. Vitev, Nucl. Phys. **B594**, 371 (2001); Phys. Rev. Lett. **85**, 5535 (2000).
- [17] U. Wiedemann, Nucl. Phys. **B588**, 303 (2000); C. A. Salgado and U. A. Wiedemann, Phys. Rev. Lett. **89**, 092303 (2002).
- [18] X. F. Guo and X.-N. Wang, Phys. Rev. Lett. **85**, 3591 (2000); X.-N. Wang and X. F. Guo, Nucl. Phys. A **696**, 788 (2001).
- [19] B. W. Zhang and X.-N. Wang, Nucl. Phys. A **720**, 429 (2003); B. W. Zhang, E. Wang and X.-N. Wang, Phys. Rev. Lett. **93**, 072301 (2004); B. W. Zhang, E. K. Wang and X.-N. Wang, Nucl. Phys. A **757**, 493 (2005).
- [20] B. Z. Kopeliovich, A. Schäfer and A. V. Tarasov, Phys. Rev. C **59** (1999) 1609 [arXiv:hep-ph/9808378].
- [21] M. Gyulassy, I. Vitev, X. N. Wang and B. W. Zhang, *Quark-Gluon Plasma 3*, R. C. Hwa and X.-N. Wang, Eds. (World Scientific, Singapore, 2003), p123-191 [arXiv:nucl-th/0302077].
- [22] A. Kovner and U. A. Wiedemann, arXiv:hep-ph/0304151.
- [23] M. Luo, J. W. Qiu and G. Sterman, Phys. Lett. B **279** (1992) 377; Phys. Rev. D **50** (1994) 1951; Phys. Rev. D **49**, 4493 (1994).
- [24] E. Wang and X.-N. Wang, Phys. Rev. Lett. **89**, 162301 (2002) [arXiv:hep-ph/0202105].
- [25] A. Airapetian *et al.* [HERMES Collaboration], Eur. Phys. J. C **20**, 479 (2001) [arXiv:hep-ex/0012049].



- [26] A. Airapetian *et al.* [HERMES Collaboration], Phys. Lett. B **577**, 37 (2003) [arXiv:hep-ex/0307023].
- [27] X. N. Wang, Phys. Lett. B **595**, 165 (2004) [arXiv:nucl-th/0305010].
- [28] T. Falter, W. Cassing, K. Gallmeister and U. Mosel, Phys. Rev. C **70**, 054609 (2004) [arXiv:nucl-th/0406023].
- [29] B. Z. Kopeliovich, J. Nemchik, E. Predazzi and A. Hayashigaki, Nucl. Phys. A **740**, 211 (2004) [arXiv:hep-ph/0311220].
- [30] V. N. Gribov and L. N. Lipatov, Sov. J. Nucl. Phys. **15**, 438 (1972); Yu. L. Dokshitzer, Sov. Phys. JETP **46**, 641 (1977); G. Altarelli and G. Parisi, Nucl. Phys. **B126**, 298 (1977);
- [31] R. D. Field, *Applications of Perturbative QCD*, Frontiers in Physics Lecture, Vol. 77, Ch. 5.6 (Addison Wesley, 1989).
- [32] M. E. Peskin and D. V. Schroeder, *An Introduction to Quantum Field Theory*, (Addison-Wesley Advanced Book Program, 1995).
- [33] J. Osborne and X.-N. Wang, Nucl. Phys. A **710**, 281 (2002) [arXiv:hep-ph/0204046].
- [34] X. N. Wang, arXiv:nucl-th/0604040.
- [35] H. L. Lai *et al.* [CTEQ Collaboration], Eur. Phys. J. C **12**, 375 (2000) [arXiv:hep-ph/9903282]; One can use the online parton distribution calculator at <http://durpdg.dur.ac.uk/HEPDATA/PDF>.
- [36] F. Gelis, K. Kajantie and T. Lappi, Phys. Rev. Lett. **96**, 032304 (2006) [arXiv:hep-ph/0508229].
- [37] W. Liu, C. M. Ko and B. W. Zhang, arXiv:nucl-th/0607047.
- [38] J. Binnewies, B. A. Kniehl and G. Kramer, Phys. Rev. D **52**, 4947 (1995) [arXiv:hep-ph/9503464].
- [39] R. Cutler and D. W. Sivers, Phys. Rev. D **17**, 196 (1978).