

# Optical element for X-ray microscopy

G.Chadzitaskos

Phys. Dept., Faculty of Nuclear Sciences and Physical Engineering,  
Czech Technical University in Prague, Břehová 7, CZ - 115 19 Prague,  
e-mail: goce.chadzitaskos@fjfi.cvut.cz

June 4, 2018

## Abstract

We present a proposal for a X-ray optical element suitable for X-ray microscopy and other X-ray-based display systems. Its principle is based on the Fresnel lenses condition and the Bragg condition for X-ray scattering on a slice of monocrystal. These conditions are fulfilled simultaneously due to a properly machined shape of the monocrystal with a stress at its ends.

**PACS:** 07.85-m,07.85Fv

## 1 Introduction

X-ray radiation is electromagnetic radiation with wavelengths shorter than 10 nm. X-ray microscopes have not used optical lenses which operate in visible part of light spectrum. Instead X-ray microscopy uses as display elements Fresnel zone plates, biconcave refractive X lenses, polycapillar optics or Göbel mirrors [1].

Fresnel zone plates are Fresnel lenses produced by means of electron lithography. Lithographic methods (but other manufacturing procedures are possible as well) can be used to create ringlets, or parts of concentric

paraboloid rings, that ensure that radiation emitted from a point on the ringlets' central axis (optical axis), having passed through the ringlets, are focused back again into a point lying on this axis. The thickness of these ringlets, or their parts, is in orders of tens of nm and their height is roughly 1000 nm. These zonal plates are used as radiation condensers for scanning and display microscopes; in display microscopes they are used also as lenses [2, 3].

Another possible way to produce Fresnel zone plates is to create a set of little plates with separate segments containing parallel strips with identical spacing between each other. The diameters of such optical elements are not greater than several centimeters [5, 4].

Biconcave refractive X lenses take the advantage of the fact that the refractive index of certain materials for X-ray radiation is only slightly higher than one. A set of identical cavities, located one after another, creates a condensing lens with long focal distance. In practice, two crossed systems of biconcave lenses are often used, each focusing the radiation in one direction only. The result is a focusing into a point, which, owing to little differences between the refractive index of the matter and the air, is located in relatively long distance from the lenses - in order of meters [6].

Göbel mirrors are plates formed by alternated thin layers of two metals, such as wolfram and silicon, with a shape of part of the surface of elliptic spheroid. These mirrors focus monochromatic X-ray radiation into a point.

Polycapillar optics is created by a set of curved capillaries, which lead the X-ray radiation and focus it into a point.

All optical elements described above feature big ratio of focal distance to their diameter. This result in relatively long focal distances and small diameters the production of which is costly. They are used in X-ray microscopy for normal as well as so-called scanning microscopes. In scanning microscopes, the beam is focused by the optics into a point on a specimen and a detector senses intensity of X-ray radiation, which has passed through. By

measuring all points - which is carried out by shifting the specimen in two mutually orthogonal directions - the specimen's final image in given wavelength is obtained. Information about intensity of the radiation from the X-ray radiation detectors or digital sensors, such as CCD cameras, which may be used instead of detectors, is stored in a computer where the final image is processed.

All examples described above result in relatively high absorption rate of X-ray radiation and all those systems also feature relatively long focal distances, i.e. distances between the display and object, and they can be used for longer wavelengths, around 10 nm. In addition, these components impose high demands on production equipment and therefore they are rather expensive.

## 2 Optical Element

Some properties mentioned above are improved by an optical set-up exploiting a monocrystal, which displays X-ray radiation with wavelength  $\lambda$  according to the presented solution. This set-up consists of at least one monocrystal with atomic planes in parallel with the optical axis, which is a line connecting the point to be displayed with the center of its image. The mutual distance of planes in resting state is  $d_0$ . The cross section of the monocrystal is variable. With respect to the optical axis of the farther or closer side of monocrystal, orthogonal to this optical axis, is equipped with a device to create a pull or push force and to maintain a pull or push strength in direction orthogonal to atomic planes of such monocrystal. The size of cross section  $S$ , of the monocrystal at a distance  $R$  from optical axis, is directly proportional to pre-selected cross section  $S_0$  and the push or pull force  $F$ . The cross section is also indirectly proportional to modulus of elasticity  $E$  of given monocrystal in the direction of force in action. The monocrystal's cross section is given by the following formula

$$S = \pm \frac{F}{E} \left( \frac{1}{\frac{n\lambda}{2Rd_0} \sqrt{R^2 + s^2} - 1} \right),$$

and the force  $F$  is defined by the equation

$$F = \pm S_0 E \left( \frac{n\lambda}{2R_0 d_0} \sqrt{R_0^2 + s^2} - 1 \right),$$

where  $s$ , with respect to the monocrystal's longitudinal axis, is an object and also a display distance and  $S_0$  is a pre-selected cross section of monocrystal upon requirements of the application in distance  $R_0$  from the optical axis and  $n$  is a natural number. In both equations, the  $+$  sign applies for pull force, the  $-$  sign applies for push force. Further, as already mentioned above,  $\lambda$  is the X-ray radiation wavelength and  $S_0$  is a pre-selected cross section in distance  $R_0$ .

In another possible embodiment, the optical set-up is formed by minimum two identical monocrystals arranged around the optical axis. All such monocrystals feature equal object and display distance  $s$ , while each monocrystal is equipped with a device applying push or pull force  $F$  within the minimum distance  $R_0$  from the optical axis and the maximum distance  $R_m$  from the optical axis. Their cross section is calculated by means of the above-mentioned equation. In other words, it is possible to arrange the monocrystals around the optical axis provided their object and display distances for the same wavelength are equal.

An advantage of this proposal is the relatively simple production of its components, which is based on Hooke's law without needing to know the exact position of individual atomic planes. Production of the current Fresnel structures involves electron lithography for individual ringlets. This method, instead requires only precise machining of the outer shape, for instance cutting using water jet or a laser, and applying a force, which can be controlled. Machining of the outer shape results in better physical effect, it means lower absorption and larger active area, with lower costs because

lithography is significantly more expensive than cutting. Another advantage is that it works for also for lower order wavelengths, i.e. below 1 nm.

### 3 Examples

An example of the optical set set-up designed by the presented proposal is shown in attached drawings. Fig. 1 shows examples of creating two different monocrystals and of basic displaying set-up. Fig. 2 shows utilization of the set-up for rotational X-ray scanning microscope. Fig. 3 shows a method of creating an optical element from multiple monocrystals and fig. 4 shows a chart of dependence of sections ratio  $S/S_0$  on distance from optical axis used for determination of pull force on atomic planes.

Fig. 1 a) and b) show two examples how monocrystal 1 can be created, with designated atomic planes 2. a) schematically shows possible shape of monocrystal 1, an asymmetric shape, designed for shifting the atomic planes by push force, while Monocrystal's 1 shape b) is designed for shifting the atomic planes by pull force. In both cases, the atomic planes 2 where the beam reflects or refracts are horizontal. The first example shows a monocrystal 1 where optical axis, i.e. a line connecting a point to be displayed with center of its image, is located under the monocrystal's 1 bigger cross section and the arrow indicates a push force applied by push device. On the contrary, b) shows situation when the monocrystal's 1 imaginary optical axis is located under the monocrystal's 1 smaller cross section and the arrow indicates a pull force applied by pull device. Push and pull devices may be implemented in various ways, such as a fixed point and piezoelectric crystal, screw mechanism and tension gauge, etc., and they can be located on one or both opposite sides of monocrystal 1. c) shows example of an optical set-up displaying X-ray radiation with wavelength  $\lambda$ . This set-up consists of monocrystal 1 with atomic planes 2, which are arranged in parallel with optical axis 3. Mutual distance of atomic planes 2 in resting state is  $d_0$  and the monocrystal's 1 cross section  $S$  is variable. On the farther side of

monocrystal 1 from the optical axis 3, orthogonal to this optical axis 3, the cross section is smaller than on the side closer to the optical axis 3, and therefore it is equipped with a push device, which is not shown in the figure. Purpose of this push device is to maintain a push force  $F$  in direction orthogonal to atomic planes 2 of this monocrystal 1.

The figure schematically shows function of symmetrically processed monocrystal 1, exposed to push force, which focuses X-ray radiation with wavelength  $\lambda$  from distance  $s$  to distance  $s$ . Both these distances must be equal. Monocrystal 1 is located between distances  $R_0$  and  $R_m$  from optical axis 3 where  $R_0$  is the minimum distance and  $R_m$  is the maximum distance from optical axis 3. Based on given equation, cross section  $S$  is a function of distance  $R$ . Subsequently, the dependence of cross section  $S$  on distance  $R$  is additionally calculated according to the given equation based on calculated force  $F$  and modulus of elasticity  $E$ . A plate with shape complying with the equation is cut from monocrystal 1. Rays emitted from a point at the object impact the monocrystal 1, reflect from individual atomic planes 2 and are projected in a display plane as shown in the figure.

In case of rotating X-ray scanning microscope with a source 4 of X-ray radiation, single monocrystal 1 may be used, embodied as shown in fig. 2, where the specimen 5 rotates around axis orthogonal to it, fixed in space, passing through the center of specimen 5. Such specimen 5 is after each revolution gradually shifted in direction of the arrow, thus allowing its scanning from one end to the other. Intensities of radiation measured by radiation detector 6 are processed by computer into the resulting image similarly as in case of tomography. Simultaneously, this monocrystal 1 acts a monochromator and a separate monochromator may thus be excluded.

Optical set-up may consist of multiple identical monocrystals 1, which are arranged around the optical axis 3 as shown in fig. 3. All these monocrystals 1 have equal object and display distance, while each monocrystal 1 is equipped with a device applying on each monocrystal 1 pull force  $F$  between

the minimum distance  $R_0$  of the bottom side of monocrystals 1 from optical axis 3 and between maximum distance  $R_m$  from optical axis 3. Their cross section is again calculated according to the given equation. Shape of monocrystals 1 may vary provided their pre-selected cross sections are maintained. In this case, as an example, an optical element consisting of 28 monocrystals 1 is shown, where atomic planes 2 act directly as a set-up of concentric polygon ringlets. By selecting suitable shape and applying suitable force in compliance with the equation it is possible to achieve a situation when among the atomic planes 2 are such distances, which cause the same constructive interference as Fresnel lens for selected wavelength, or possibly also for wavelength, which is half of such wavelength, its third, etc., and act simultaneously as a monochromator, which selects only these wavelengths from the whole spectrum used. The same effect may be achieved by using suitable gradient of admixtures in crystal, such as hydrogen in gadolinium, which affects interatomic distance. Implementation of detectors is the same as in other cases.

Fig. 4 shows chart with dependencies of sections ratios  $S/S_0$  of monocrystal 1 on distance from optical axis 3 used for determination of pull force on atomic planes 2 for the following values:  $\lambda = 0.1$  nm,  $d_0 = 0.4$  nm,  $R_0 = 0.01$  m,  $s = 0.5$  m and  $n = 1$ , in the extent up to  $R_m = 0,07$  m.

## Acknowledgements

The authors wish to acknowledge support of the Ministry of Education of Czech Republic under the research project MSM6840770039.

## References

- [1] S.D. Padiyar, Hui Wang, M.V. Gubarev,\* W.M. Gibson, and C.A. MacDonald, "Beam Collimator using Polycapillary X-ray optics for Large

Area Diffraction Applications", *Advances in X-ray Analysis*, Vol.43, 254-259 (2000)

- [2] B.Niemann,D.Rudolph, G.Schmahl "X-ray microscopy with synchrotron radiation", *Appl.Optics* **15**, 1883 (1976)
- [3] G.Schmahl, D.Rudolph, P.Guttman, O.Christ "Zone Plates for X-Ray Microscopy", in: *X-Ray Microscopy*, Springer Series in Optical Sciences **43**, 63 (1984)
- [4] H.I.Smith et al., "Planar Techniques for Fabrication of X-ray Diffraction Gratings and Zone Plates, in: *X-ray Microscopy*, Springer Series in Optical Sciences, Vol. 43, 51 (1984)
- [5] W.Chao, B.D.Harteneck, J.A.Liddle, E.H.Andersen, D.Atwood, "Soft X-ray Microscopy at a Spatipal Resolution Better thah 15 nm", *Nature*, Vol. 435, 1210-1213 (2005)
- [6] B.Lengeler et al., " Parabolic refractive X-ray lenses: a breakthrough in X-ray optics" *Nuclear Instruments and Metods in Physics Research A* 467-468, 944 - 950 (2001)



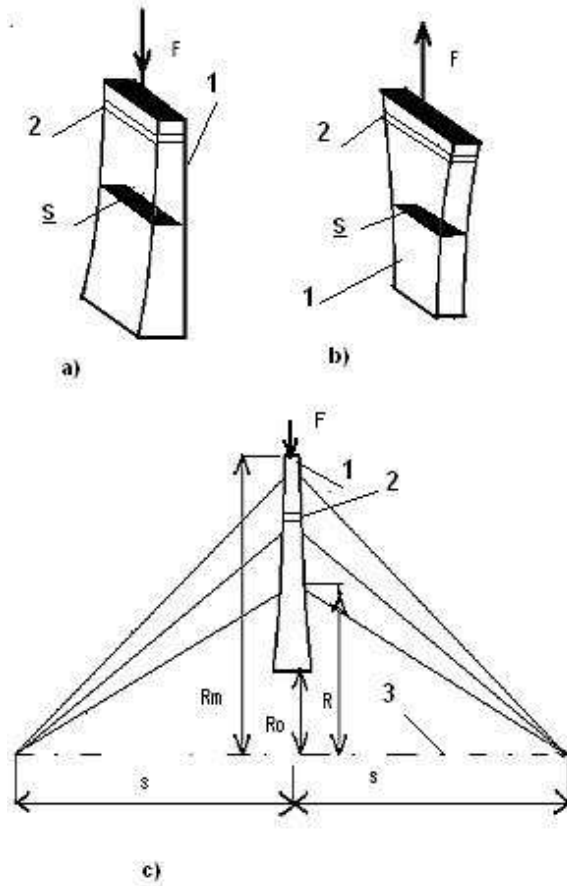

Figure 1: a) and b) show two examples of possible shape of monocrystal 1, designed for shifting the atomic planes 2 by push and pull force  $F$ . c) shows example of an optical set-up displaying X-ray radiation with wavelength  $\lambda$ . It consists of monocrystal 1 with atomic planes 2, which are parallel with optical axis 3. Mutual distance of atomic planes 2 in resting state is  $d_0$  and the monocrystal's 1 cross section  $S$  is variable. It is equipped with a push device to maintain a push force  $F$  in direction orthogonal to atomic planes 2 of this monocrystal 1, located between distances  $R_0$  and  $R_m$

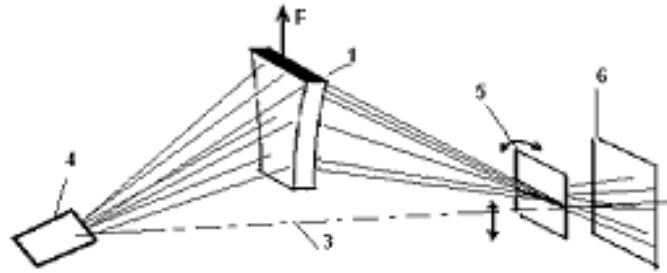

Figure 2: Rotating X-ray scanning microscope consists of a source 4 of X-ray radiation, single monocrystal and the specimen 5. The specimen 5 is after each revolution shifted in direction of the arrow, thus allowing its scanning from one end to the other. Intensities of radiation measured by radiation detector 6 are processed by computer into the resulting image similarly as in case of tomography. Simultaneously, this monocrystal 1 acts a monochromator and a separate monochromator may thus be excluded.

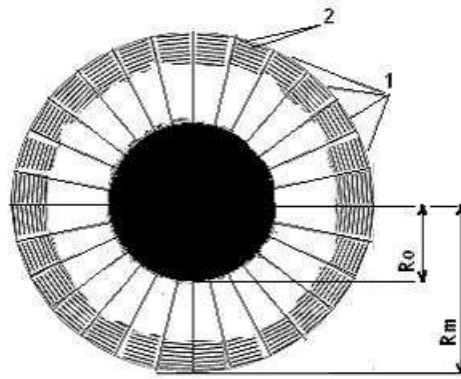

Figure 3: Optical element consisting of 28 monocrystals

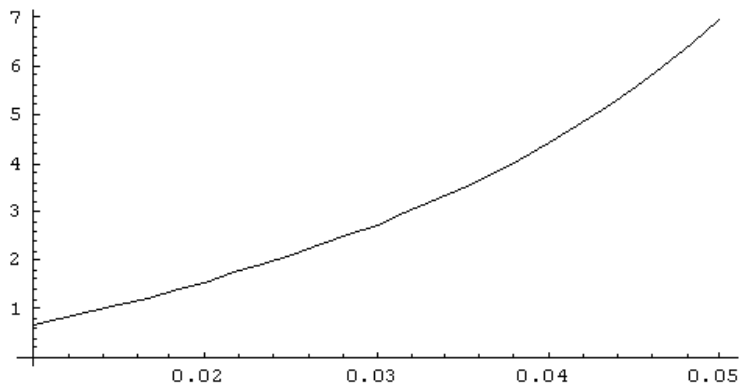

Figure 4: dependencies of sections ratios  $S/S_0$  of monocrystal 1 on distance from optical axis 3 used for determination of pull force on atomic planes 2 for the following values:  $\lambda = 0.1$  nm,  $d_0 = 0.4$  nm,  $R_0 = 0.01$  m,  $s = 0.5$  m and  $n = 1$ , in the extent up to  $R_m = 0,07$  m.