

Very simple FET amplifier with a voltage noise floor less than $1 \text{ nV}/\sqrt{\text{Hz}}$

Luca Callegaro, Marco Pisani, Alessio Pollarolo

Istituto Nazionale di Ricerca Metrologica (INRIM)

Strada delle Cacce, 91 - 10135 Torino, Italy

E-mail: l.callegaro@inrim.it

Abstract. A field-effect transistor (FET) amplifier for small voltage signals is presented. Its design is elementary and the construction can be afforded by anyone. Despite its simplicity, with a voltage noise less than $1 \text{ nV}/\sqrt{\text{Hz}}$, it outperforms commercially available integrated FET amplifiers. The amplifier has a gain flatness better than 1 dB over 1 MHz bandwidth; it can be employed as a front-end for signal analyzers or signal recovery systems.

PACS numbers: 05.40.Ca, 07.50.-e, 07.50.Qx, 84.30.Le

Keywords low noise amplifier; FET amplifier; cascode

1. Introduction

The experimentalists often need a preamplifier for small voltage signals with an high input impedance and the lowest possible noise.

Amplifiers based on commercial field-effect transistors (FET) integrated circuits (IC) are very simple to construct, and provide a number of friendly properties (internal compensation, wide bandwidth, wide supply voltage range, high power-supply rejection ratio, etc). However, they have equivalent input voltage noise not lower than ≈ 5 nV/ $\sqrt{\text{Hz}}$. On the other end, the construction and trimming of amplifiers based on discrete FETs (see e.g. Refs. [1, 2, 3, 4, 5, 6]) could be sometimes tough for the general experimentalist.

In the following, we describe a very simple FET amplifier, which construction simplicity is comparable to those of IC-based amplifiers. It has a number of friendly properties and its voltage noise floor is better than 1 nV/ $\sqrt{\text{Hz}}$.

2. The circuit

The circuit is shown in Fig. 1.

The transistor T, directly connected to the input voltage V_{in} , is an FET in a common-source configuration. T works with a gate-source bias voltage $V_{\text{GS}} \approx 0$. ‡

The wiring to V_{in} proposed in Fig. 1 allows a pseudo-differential configuration. This can help in reducing interferences or, in correlation measurements [7], permits a four-terminal connection to the device under test.

The op amp A works as a transresistance amplifier with gain R , and sets the FET transistor in a cascode configuration [8, 9] (which eliminates the Miller effect [10], thus enhancing the bandwidth). The drain-source voltage V_{DS} is set by A at the voltage V_{B} of the polarization battery B. B is practically unloaded (I_{B} is the small bias current of A), hence it has a long life, and V_{B} has an extremely low noise [11].

A works in a single-supply configuration; its output V_{out} is ac-coupled through capacitor C , and can be further amplified by additional stages if necessary.

The overall low-frequency gain $G = +g_{\text{m}} R$ of the amplifier depends on R and the FET transconductance g_{m} , which can have significant deviations from one sample to another. Therefore, depending on the application, a calibration of G with a reference signal may become necessary [7].

Several other properties of the amplifier, like the compensation, bandwidth flatness, large supply voltage range, high power-supply rejection ratio (PSRR), are given by A.

Typical supply voltage is $V_{\text{CC}} = +24$ V from an unregulated battery; the power load is ≈ 15 mA.

‡ A drawback of such configuration is the limited dynamic range, a few tens of mV at the input, before distortion occurs.

3. Experimental

The circuit is simple to construct and does not require any trimming.

Examples of suitable low-noise FETs are 2SK170 (Toshiba), LSK170 (Linear Systems), LSK389 (dual FET, Linear Systems); Tab. 1 shows an extract of the corresponding datasheets. A prototype has been assembled with a 2SK170, using an OP27 (various suppliers) for A. We set $R = 1 \text{ k}\Omega$. The bias current is $2 \div 3 \text{ pA}$ (measured with a Keithley mod. 6430 current meter), which gives a current shot noise less than $1 \text{ fA}/\sqrt{\text{Hz}}$.

The transfer function of the amplifier is shown in Fig. 2. It has been measured with a network analyzer (Agilent Tech. mod. 4395A), injecting the signal with a resistive divider (50Ω - 0.5Ω). A 3 dB-bandwidth of $\approx 4 \text{ MHz}$ can be estimated, with a gain flatness better than 1 dB up to 1 MHz.

The equivalent input voltage noise with short-circuited input is shown in Fig. 3. It has been measured with a two-channel signal analyzer (Agilent Tech. mod. 35670A) by connecting V_{out} to both channels and performing a cross-correlation measurement in order to reject the analyzer noise. The noise floor is $\approx 0.8 \text{ nV}/\sqrt{\text{Hz}}$, corresponding to the Johnson noise of a $\approx 38 \Omega$ resistor at 300 K.

4. Conclusions

The amplifier can be of interest in a number of applications, in particular as an input front-end for commercial instrumentation (signal analyzers, lock-in amplifiers).

Two prototypes of the amplifier have been employed in a correlation spectrum analyzer, developed for accurate measurement of the Johnson noise of a $1 \text{ k}\Omega$ resistor [7]. The experiment is still under development, but the amplifier has shown excellent properties, comparable with more sophisticated setups [6]. Despite the open-loop configuration, after an initial warm-up time the gain mid-term stability is within one part in 10^3 in a laboratory environment.

Acknowledgments

The authors warmly thank Massimo Ortolano, Politecnico di Torino, for fruitful discussions and for reviewing the manuscript.

- [1] H. H. Klein, G. Klempt, and L. Storm. Measurement of the thermodynamic temperature of ^4He at various vapour pressures by a noise thermometer. *Metrologia*, 15:143–154, 1979.
- [2] S. R. Jefferts. A very low-noise fet input amplifier. *Rev. Sci. Instrum.*, 60:1194–1196, Jun 1989.
- [3] B. Neri, B. Pellegrini, and R. Saletti. Ultra low-noise preamplifier for low-frequency noise measurements in electron devices. *IEEE Trans. Instr. Meas.*, 40:2–6, Feb 1991.
- [4] R.M. Howard. Low noise amplifier design and low noise amplifiers for characterizing the low frequency noise of infrared detectors. *Optoelectronic and Microelectronic Materials Devices, 1998. Proceedings. 1998 Conference on*, pages 179–182, 1999. See Fig. 5.
- [5] G. Ferrari and M. Sampietro. Correlation spectrum analyzer for direct measurement of device current noise. *Rev. Sci. Instrum.*, 73:2717–2723, July 2002.
- [6] J. T. Zhang and S. Xue. A noise thermometry investigation of the melting point of gallium at the NIM. *Metrologia*, 43:273–277, 2006.
- [7] M. Pisani L. Callegaro and A. Pollarolo. Traceable Johnson noise measurements in the audio frequency range. In *CPEM 2008 Conf. Digest*, Broomfield, CO, USA, Jun 2008. in press.
- [8] F. V. Hunt and R. W. Hickman. On electronic voltage stabilizers. *Rev. Sci. Instrum.*, 10:6–21, January 1939.
- [9] P. Horowitz and W. Hill. *The art of electronics*. Cambridge University Press, 2nd edition edition, 1989.
- [10] J. M. Miller. Dependence of the input impedance of a three-electrode vacuum tube upon the load in the plate circuit. *Scient. Papers Bureau of Standards*, 15:367–385, 1919-20.
- [11] C. K. Boggs, A. D. Doak, and F. L. Walls. Measurement of voltage noise in chemical batteries. *Frequency Control Symposium, 1995. 49th., Proceedings of the 1995 IEEE International*, pages 367–373, May-2 Jun 1995.

Table 1. Main specifications of FET models suggested in Sec. 3, from manufacturer datasheets in typical operating conditions.

Symbol	description	2SK170BL	LSK170B	LSK389B
g_m	transconductance	22 mS	22 mS	20 mS
e_n	noise voltage (1 kHz)	$0.95 \text{ nV}/\sqrt{\text{Hz}}$	$0.9 \text{ nV}/\sqrt{\text{Hz}}$	$0.9 \text{ nV}/\sqrt{\text{Hz}}$
C_{in}	input capacitance	30 pF	20 pF	25 pF
I_{DSS}	drain current	$6 \div 12 \text{ mA}$	$6 \div 12 \text{ mA}$	$6 \div 12 \text{ mA}$

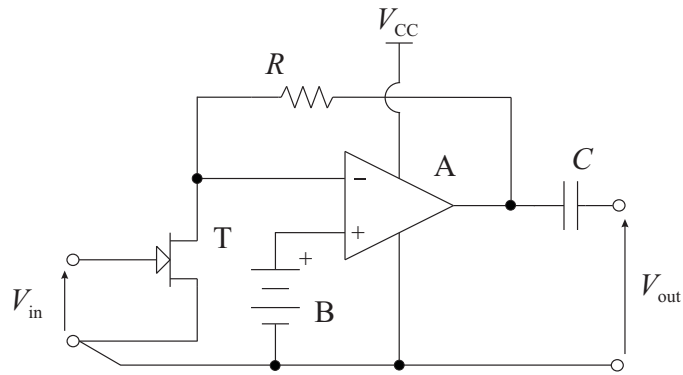

Figure 1. The schematic of the proposed amplifier. See text for an explanation of the symbols.

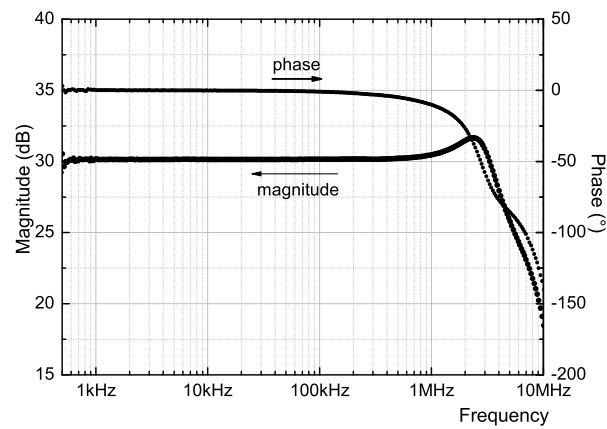

Figure 2. The transfer function of the amplifier, in magnitude and phase representation.

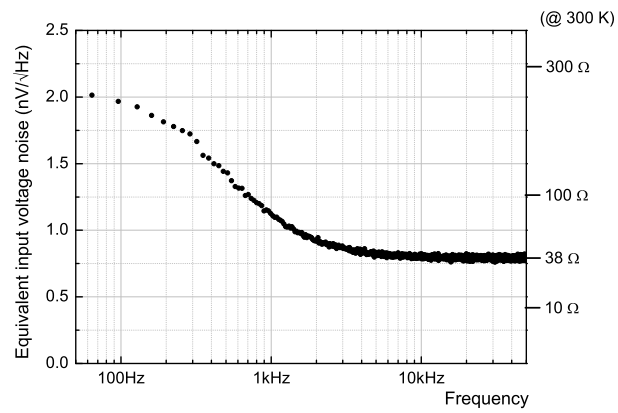

Figure 3. Equivalent input voltage noise of the amplifier.