

CLARO-CMOS, a very low power ASIC for fast photon counting with pixellated photodetectors

Paolo Carniti^{a,b}, Marcello De Matteis^c, Andrea Giachero^{a,b},
Claudio Gotti^{a,d*}, Matteo Maino^{a,b}, Gianluigi Pessina^{a,b}

^aINFN, Sezione di Milano Bicocca, Piazza della Scienza 3, 20126, Milano, Italy

^bDipartimento di Fisica G. Occhialini, Università degli Studi di Milano Bicocca,
Piazza della Scienza 3, 20126, Milano, Italy

^cDipartimento di Ingegneria dell'Innovazione, Università del Salento,
Via Per Monteroni, 73100, Lecce, Italy

^dDipartimento di Elettronica e Telecomunicazioni, Università degli Studi di Firenze,
via S. Marta 3, 50139, Firenze, Italy

E-mail: claudio.gotti@mib.infn.it

Abstract

The CLARO-CMOS is an application specific integrated circuit (ASIC) designed for fast photon counting with pixellated photodetectors such as multi-anode photomultiplier tubes (Ma-PMT), micro-channel plates (MCP), and silicon photomultipliers (SiPM). The first prototype has four channels, each with a charge sensitive amplifier with settable gain and a discriminator with settable threshold, providing fast hit information for each channel independently. The design was realized in a long-established, stable and inexpensive 0.35 μm CMOS technology, and provides outstanding performance in terms of speed and power dissipation. The prototype consumes less than 1 mW per channel at low rate, and less than 2 mW at an event rate of 10 MHz per channel. The recovery time after each pulse is less than 25 ns for input signals within a factor of 10 above threshold. Input referred RMS noise is about 7.7 ke^- (1.2 fC) with an input capacitance of 3.3 pF. Thanks to the low noise and high speed, a timing resolution down to 10 ps RMS was measured for typical photomultiplier signals of a few million electrons, corresponding to the single photon response for these detectors.

Keywords: Pixelated detectors and associated VLSI electronics; Cherenkov detectors; Instrumentation and methods for time-of-flight (TOF) spectroscopy; Analogue electronic circuits; Front-end electronics for detector readout; VLSI circuits

*Corresponding author

1 Introduction

The fast counting of photons down to the single photon level is a basic requirement shared among several applications, ranging from particle identification in fundamental physics to imaging of biological processes in nuclear medicine. In many cases the applications require pixellated photodetectors with pixel size of the order of a few squared millimeters, often placed side by side to increase the total photosensitive area. The total number of pixels can be very large, ranging up to the order of 10^5 . The case of ring imaging Cherenkov (RICH) detectors is one of the most demanding. In this case, the photodetectors are usually arranged to form planes of up to a few squared meters, ideally with no dead space between pixels.

Among the photodetectors which may be employed, multi-anode photomultiplier tubes (Ma-PMT), thanks to the negligible dark count rate, are most often the baseline for RICH detectors. New time of flight (TOF) detector designs often employ light sensors with superior time resolution, such as microchannel plates (MCP). Scintillator-based detectors usually generate a larger number of photons per event, and can thus take advantage of light detectors with a higher dark count rate, but lower cost, such as silicon photomultipliers (SiPM). From the point of view of the readout electronics, the signals from these photodetectors have very similar characteristics, and the same readout circuits can be used with minor adjustments. The typical photomultiplier gain is of the order of 10^6 , and the expected pixel capacitance is of the order of a few pF. The charge collection time is small, of the order of one nanosecond. Other kind of photosensors exist which require different design solutions for the readout electronics, but are not considered here.

The main challenges in the realization of the electronic readout of such systems stem from the large number and close packing of the readout channels. This requires a low power dissipation to minimize cooling issues. Other frequent requirements are the sustainability of high count rates or the allowance of precise timing measurements. These call for wide bandwidth, which is in contrast with low power dissipation. Wide bandwidth also requires the minimization of the capacitance between pixels, which can be a major source of crosstalk. To minimize capacitance the front end electronics must be as close as possible to the photosensors, which also helps in minimizing noise. But this poses design issues which go back to power dissipation and cooling. These trade-offs need to be tuned to the specificities of each application.

Several application specific integrated circuits (ASIC) for photodetector readout are already available, covering a wide range of applications [1, 2, 3, 4, 5, 6, 7]. For instance, an ASIC suitable for timing measurements with a resolution of 20 ps RMS is the NINO [1], designed in IBM 0.25 μm CMOS technology, with a power consumption of 27 mW per channel. On the other side, an ASIC for fast photon counting with a lower power consumption is the MAROC [2], designed in AMS 0.35 μm SiGe-BiCMOS technology, which consumes about 5 mW per channel but was not designed for precise timing measurements.

The technological advances driven by the field of digital electronics and of

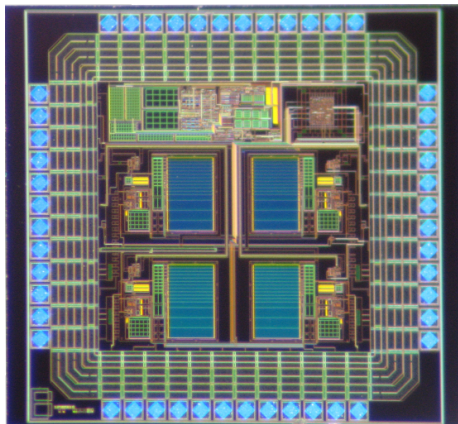

Figure 1: A photograph of the 4-channel CLARO-CMOS prototype.

commercial portable communication devices, which also require wide bandwidth at low power, can result in significant improvements in the field of fast photodetector readout. Nevertheless careful design in a rather aged (and inexpensive) purely CMOS technology, such as the $0.35\ \mu\text{m}$ from AMS, can still yield excellent results at the cutting edge of timing performance and low power. This is the aim followed in the design of the CLARO-CMOS, the first prototype of an ASIC for photodetector readout presented in this paper. Figure 1 shows a photograph the 4-channel ASIC. The die area is $2 \times 2\ \text{mm}^2$.

The radiation hardness of the technology adopted is expected to be adequate for most accelerator and space environments [8, 9]. However the effects of radiation on the circuit performance depend also on the design and layout of a given device. The radiation hardness of the CLARO-CMOS prototype will be measured in the near future, but is not considered in this paper.

2 Design of the prototype

Figure 2 shows the block diagram of a channel of the CLARO-CMOS. The ASIC is designed for operation between a positive 2.5 V supply rail and ground. The charge sensitive amplifier (CSA) converts the input current pulse into a voltage signal, which is AC coupled to a PMOS follower and to a discriminator (a voltage comparator). The threshold of the discriminator is set by the programmable static voltage at the non-inverting input of the comparator. The schematics of the charge sensitive amplifier and of the comparator will be described in detail in the following.

As will become clear later, the DC voltage at the output of the CSA is close to the positive rail and its value is not stable against temperature variations. For these reasons the AC coupling shown in figure 2 was introduced. In this way the DC voltage at the inverting input of the comparator is held at half-way

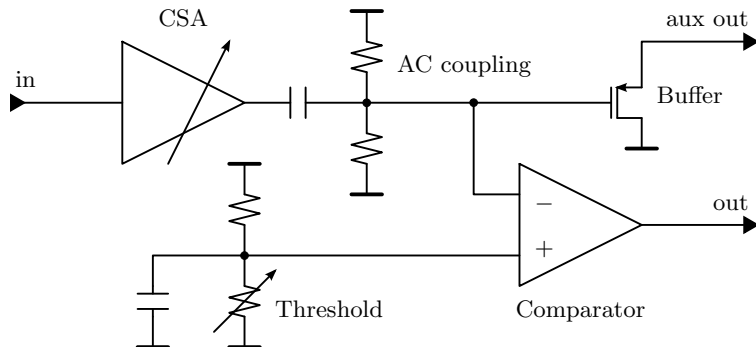

Figure 2: The block diagram of a CLARO-CMOS channel.

between the positive rail and ground, and is independent of temperature. The AC coupling time constant is 55 ns. Since, as will be shown, the signals at the output of the CSA are very fast, no noticeable baseline shift is caused by the AC coupling unless the rate is larger than about 10 MHz.

The auxiliary output buffer realized with a small area PMOS follower is primarily used for debugging purposes: it allows to measure the signals at the inverting input of the discriminator without loading the output of the CSA. It needs to be biased by an external resistor tied to the positive supply voltage, and is meant to be switched off during normal operation, when the threshold is properly set and only the binary information at the output of the discriminator is readout. In all the power consumption measurements presented in the following, the analog buffer was off.

Gain and threshold are programmable thanks to a 16-bit shift register, very similar to a SPI interface. The first 8 bits control channel 1. Three bits are used to control the gain of the CSA, as will be described in the following, and the remaining five bits control the resistive divider at the noninverting input of the comparator. The second group of 8 bits controls channel 2. In this prototype, settings for channels 3 and 4 are copied from those of channels 1 and 2.

The design of the CLARO-CMOS is optimized for negative input charge signals, that is, the ASIC is designed to be used with photodetectors where electrons are collected at the readout electrode. To accommodate the case where the photodetector signals are made of holes, as for some SiPM models, the same design could be reversed by changing all NMOS transistors with PMOS transistors and viceversa in the CSA, and threshold settings should be changed accordingly.

2.1 Design of the CSA

Figure 3 shows a simplified schematic of the CSA, which includes the parasitic capacitance C_L and the input capacitance C_I for clarity. The input stage is an active cascode [10, 11, 12], a design widely used in the field of photodetector

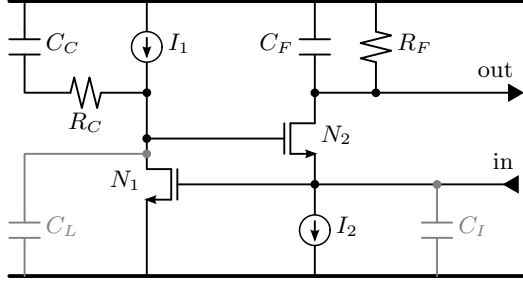

Figure 3: Simplified schematic of the charge sensitive amplifier (CSA). The parasitic capacitances C_L and C_I are shown in grey. C_I also includes the sensor capacitance.

electronics, also referred to as super common base [13, 14, 15]. This design uses a local feedback through N_1 to lower the impedance at the source of N_2 , in order to read the input current pulses on a virtual ground node. The loop gain at intermediate frequency is $g_1 R_C$, where g_1 is the transconductance of N_1 . The current pulses are integrated by the capacitor C_F at the drain of N_2 , which discharges through the resistor R_F . The output signal in response to a (negative) charge Q injected at $t = 0$ is given by

$$V_O(t) = \frac{Q}{C_F} \frac{\tau_F}{\tau_F - \tau_R} \left(e^{-t/\tau_F} - e^{-t/\tau_R} \right) \quad (1)$$

where τ_R is the rise time constant given by the CSA bandwidth and $\tau_F = C_F R_F$ is the fall time constant. The rise time constant τ_R is of the order of 1 ns, and is directly proportional to C_I as will be shown. The ASIC is designed for fast photodetectors, where the input current pulse is short, of the order of 1 ns. The fall time constant τ_F was chosen to be 5 ns, large enough for an effective integration of fast pulses but small enough to sustain high rates without pile-up.

In the simplified scheme of figure 3, the main voltage (or series) noise source is N_1 together with the bias circuit I_1 , while the main current (or parallel) noise source is R_F together with the bias circuit I_2 . Transistor N_2 contributes to the series noise, but its contribution is divided by the loop gain and becomes negligible. The optimal noise performance corresponds to the case where N_1 is biased with a large current I_1 to keep its transconductance high and its series noise low. Since R_F contributes to the parallel noise, its value cannot be too small, and this poses an upper limit to the bias current I_2 of N_2 . With a low bias current, the transconductance g_2 of N_2 is low, and the input capacitance to ground C_I due to the input bonding pad, the bonding wire, packaging, interconnects and to the sensor adds a pole to the input feedback loop at a frequency $g_2/2\pi C_I$. If R_C and C_C were not present, the load at the drain of N_1 would be purely capacitive, and there would be another pole at very low frequency due to C_L . This would be the lower frequency pole of the feedback loop. At the

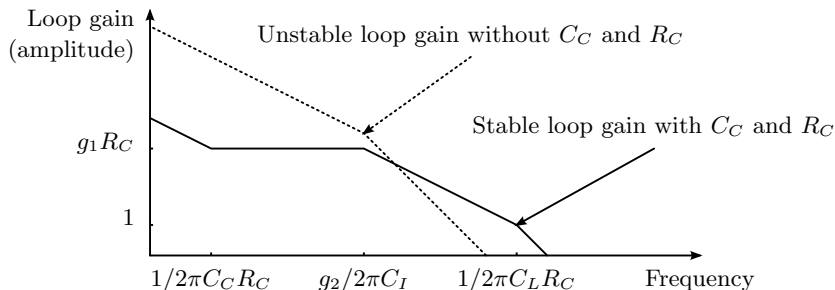

Figure 4: Bode diagram illustrating the stability of the input feedback loop.

frequency of the second pole, that is $g_2/2\pi C_I$, the feedback loop would become unstable, unless it were already lower than 1, in which case it would be ineffective in lowering the input impedance at this frequency. This case is illustrated in the bode plot of figure 4, dashed line.

To compensate the pole due to C_L , R_C and C_C are used. This case is illustrated in the solid line of figure 4. The effect of compensation is to limit the loop gain to $g_1 R_C$ at moderate frequency, higher than $1/2\pi C_C R_C$. This shifts the pole due to C_L at a higher frequency given by $1/2\pi C_L R_C$. For this compensation to be effective, it is required that the value of R_C is not too large and that C_L is minimized with a proper layout. In particular, since the area of C_C on silicon is larger than that of R_C , its parasitic capacitance to the substrate is larger. A much lower value for C_L is obtained if R_C is placed before C_C , as in figure 3. The relatively low value for R_C strengthens the need to keep high the transconductance of N_1 , while the transconductance of N_2 is less critical. As illustrated in the solid line of figure 4, the dominant pole of the input feedback loop is now at $g_2/2\pi C_I$. This ensures that the feedback loop is effective in lowering the input impedance up to a much higher frequency. The frequency where the loop gain becomes close to unity gives the bandwidth of the CSA. The associated time constant gives the rise time of the output signal:

$$\tau_R = \frac{C_I}{g_2} \frac{1}{g_1 R_C + 1} \simeq \frac{C_I}{g_2 g_1 R_C} \quad (2)$$

The 10% to 90% rise time is given by $2.2\tau_R$. The rise time is thus directly proportional to the input capacitance C_I and inversely proportional to the loop gain $g_1 R_C$. The stability of the feedback loop is ensured even if the sensor has a negligible capacitance, since the value of C_I has a lower limit at a few pF due to the gate-drain capacitance of N_1 , that is less than 100 fF but its contribution is multiplied by the loop gain, its gate-source and gate-bulk capacitance (about 0.5 pF in total) and the stray capacitance of the pads, the bonding wires, eccetera. Considering all the contributions from the circuit the input capacitance can be estimated to be about 1.5 pF, bonding pads excluded. With the CLARO-CMOS mounted in a small QFN48 package the total capacitance at the input (without the sensor) was measured to be about 3.3 pF.

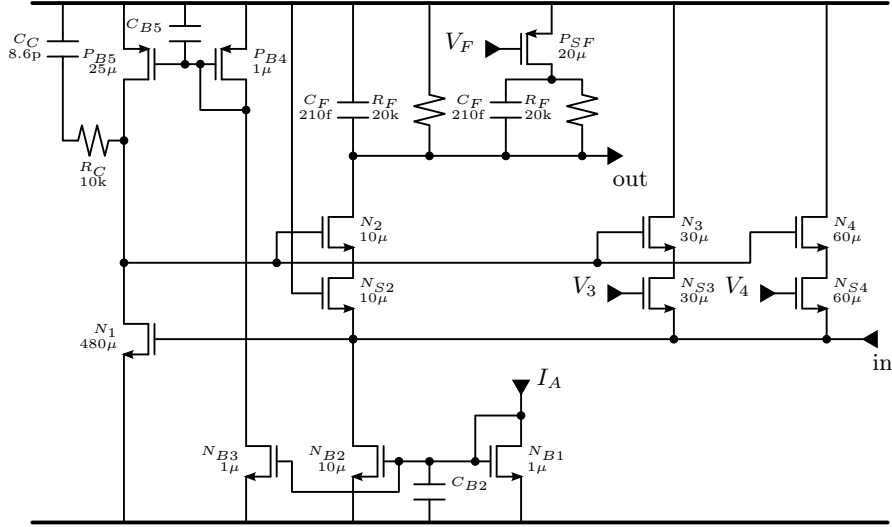

Figure 5: Full schematic of the CSA. The width of the MOS transistors is shown. The gate length is $0.35 \mu\text{m}$ for all the transistors in the CSA. The substrate of all NMOS (PMOS) transistors is tied to ground (to the positive rail).

The full schematic of the CSA is shown in figure 5. To vary the gain, a set of MOS switches was included in the design. Two switches, N_{S3} and N_{S4} , are used to attenuate the input signal: if the digital control signals V_3 or V_4 are set high, the switches are closed and a part of the input charge passes through N_3 or N_4 and is wasted on the positive rail. The amount of attenuation B is set by choosing the dimensions of N_3 and N_4 , which are 3 and 6 times larger than N_2 respectively, causing attenuations of $B = 4$ and $B = 7$. An attenuation of a factor of $B = 10$ is obtained if both branches are enabled. The dummy switch N_{S2} whose gate is tied to the positive rail was introduced to preserve the symmetry between the input branches.

Another switch P_{SF} controlled by the digital control signal V_F is used to change the value of C_F and R_F , doubling C_F and halving R_F , to change the gain by a factor of 2 while keeping the discharge time constant the same. The voltages V_3 , V_4 and V_F are the three control bits which allow gain setting on each channel. The reason why only one switch was used to change the values of C_F and R_F is related to the switch parasitics. If several switches were connected in series, their series resistance in the "on" state would have caused distortion in the shape of the output signal. If several of such switches were put in parallel, their capacitance in the "off" state would have been in parallel with C_F , reducing the maximum gain achievable.

The dimensions of the bias transistors $N_{B1} \dots N_{B5}$ were chosen so that the bias current of N_1 is about 2.5 times larger than that of N_2 . Transistor N_1 has a very large area to obtain a high transconductance g_1 . In this prototype the

bias current of the CSA can be set by changing I_A with an external resistor. Two operating modes were chosen: a “low power” mode, with $I_A = 2 \mu\text{A}$, and a “timing” mode, with $I_A = 5 \mu\text{A}$. In “low power” mode, N_1 is biased with $85 \mu\text{A}$, resulting in $g_1 = 2 \text{ mA/V}$. Since $R_C = 10 \text{ k}\Omega$, the low frequency gain of the input feedback loop is about 20. The input branches with N_2, N_3, N_4 are biased with a total current $25 \mu\text{A}$. The total transconductance of N_2 in parallel with N_3 and N_4 is about $350 \mu\text{A/V}$, depending on which of N_3 and N_4 are enabled. If the feedback loop were not present, the input impedance would be higher than $2 \text{ k}\Omega$. The feedback loop lowers this value to about 130Ω . From equation 2 the 10% to 90% rise time is expected to be about 1.2 ns for $C_I = 3.3 \text{ pF}$, and 2.4 ns for $C_I = 6.5 \text{ pF}$. In “timing” mode, N_1 is biased with $170 \mu\text{A}$, and its transconductance becomes 3.8 mA/V , so that the loop gain roughly doubles. The total transconductance of N_2, N_3 and N_4 is about $500 \mu\text{A/V}$. Thanks to the larger loop gain, the input impedance is now reduced to less than 100Ω . The bandwidth of the CSA is increased, and the loop gain at $1/2\pi C_L R_L$ becomes closer to unity, but stability of the feedback loop is still ensured even with a negligible sensor capacitance. The rise time of the signal at the output of the CSA as given by equation 2 is roughly half than in “low power” mode thanks to the larger loop gain. The main consequence is a reduction of the time walk of the discriminator, as will be shown in the following.

The noise of the CSA can be referred to the input as an equivalent noise charge (ENC). The detailed noise calculations are given in appendix A.1. For $\tau_R \ll 0.3 \tau_F$, that is for $C_I \ll 10 \text{ pF}$ in “low power” mode, the ENC is given by

$$\text{ENC} \simeq \left(i_n^2 \frac{\tau_F + 3\tau_R}{4} + e_n^2 C_I^2 \frac{\tau_F + 3\tau_R}{4\tau_F\tau_R} + A_f C_I^2 \frac{\tau_F + 4\tau_R}{\tau_F} \ln \frac{\tau_F}{\tau_R} \right)^{\frac{1}{2}} \quad (3)$$

where i_n is the current noise density, e_n is the white voltage noise density and A_f is the $1/f$ voltage noise coefficient. In addition to the noise from N_1 and R_F , it is necessary to consider the noise contributions coming from the bias transistor N_{B2} , whose current noise directly contributes to the parallel noise at the input, and P_{B5} , whose current noise is divided by the transconductance of N_1 and becomes a series noise contribution at the input. Moreover, if the value of the filtering capacitors C_{B2} and C_{B5} is not large enough, additional noise coming from N_{B1}, N_{B3} and P_{B4} can be injected through N_{B2} and P_{B5} , contributing to the parallel and series noise respectively.

In this first CLARO-CMOS prototype, filter capacitors C_{B2} and C_{B5} are not present. The parallel noise is dominated by the channel current of N_{B1} mirrored and multiplied by 10 by N_{B2} . Since in “low power” mode the transconductance of N_{B1} is $g_{B1} = 35 \mu\text{A/V}$ we have

$$i_{B1}^2 = 10^2 \times \frac{8}{3} kT g_{B1} \simeq \left(6.2 \text{ pA}/\sqrt{\text{Hz}} \right)^2 \quad (4)$$

Other contributions come from N_{B2} , about $2 \text{ pA}/\sqrt{\text{Hz}}$, and from R_F , about $0.9 \text{ pA}/\sqrt{\text{Hz}}$ if $V_F = 1$, $1.3 \text{ pA}/\sqrt{\text{Hz}}$ if $V_F = 0$, assuming $B = 1$. The weight of the noise generated by R_F is directly proportional to the attenuation factor B :

at the maximum attenuation, that is with $B = 10$, the noise from R_F becomes the dominant parallel noise source with $9 \text{ pA}/\sqrt{\text{Hz}}$ if $V_F = 1$, $13 \text{ pA}/\sqrt{\text{Hz}}$ if $V_F = 0$. The other noise sources in the CSA do not depend on B , since they share the same attenuation as the signal. Anyway the attenuation is meant to be used only when the signals are large; so in those cases the signal to noise ratio is expected to be anyway adequate. In the following, for all noise evaluations, we will consider $B = 1$. The sum of all parallel noise is thus close to $7 \text{ pA}/\sqrt{\text{Hz}}$ in “low power” mode with $B = 1$. In “timing” mode the parallel noise increases by about 20% due to the larger bias current which gives a larger transconductance to N_{B1} and N_{B2} .

The series noise is dominated by N_1 and P_{B5} . As already mentioned, additional noise from the other bias transistors is injected through P_{B5} since its gate is not filtered. In “low power” mode, where $g_1 = 2 \text{ mA}/\text{V}$, the series white noise is dominated by N_{B1} , N_{B3} and P_{B4} , which all have a transconductance of about $g_{B1} = 35 \text{ }\mu\text{A}/\text{V}$. The resulting white voltage noise at the input is

$$e_{B134}^2 = 25^2 \times 3 \times \frac{8}{3} kT \frac{g_{B1}}{g_1^2} \simeq \left(13 \text{ nV}/\sqrt{\text{Hz}}\right)^2 \quad (5)$$

being 25 the area ratio between P_{B5} and P_{B4} . Other contributions come from N_1 , about $2.3 \text{ nV}/\sqrt{\text{Hz}}$, and from P_{B5} , about $1.6 \text{ nV}/\sqrt{\text{Hz}}$. The sum of all series white noise is about $e_n \simeq 14 \text{ nV}/\sqrt{\text{Hz}}$. In “timing” mode the series noise reduces by almost a factor of 2, because of the larger transconductance of N_1 which gives a larger loop gain. Compared to the series white noise, the contribution of the $1/f$ component is expected to be negligible since from simulations it is possible to estimate $A_f \leq 10^{-9} \text{ V}^2$.

According to equations 2 and 3, the parallel noise contribution to the ENC at the output of the CSA is expected to be about 1.8 ke^- (0.29 fC) at $C_I = 3.3 \text{ pF}$, and 2.0 ke^- (0.32 fC) at $C_I = 6.5 \text{ pF}$. The series noise contribution is expected to be about 7.5 ke^- (1.2 fC) at $C_I = 3.3 \text{ pF}$, and 12 ke^- (1.9 fC) at $C_I = 6.5 \text{ pF}$. The total noise of the CSA is thus expected to be 7.7 ke^- (1.2 fC) at $C_I = 3.3 \text{ pF}$, and 12 ke^- (1.9 fC) at $C_I = 6.5 \text{ pF}$. At the auxiliary output, the rise time is limited by the bandwidth of the analog buffer. In that case the weight of the series noise is expected to be smaller, while the weight of the parallel noise is expected to be larger, according to equation 3. For instance, assuming that the output buffer limits the output signals with time constants of $\tau_R = 1.3 \text{ ns}$ and $\tau_F = 7.2 \text{ ns}$, equation 3 gives 5.6 ke^- (0.89 fC) with an input capacitance of 3.3 pF , dominated by the series noise.

As already discussed, the filtering capacitors C_{B2} and C_{B5} can be used to improve the noise performance of the design, considerably reducing both the series and the parallel noise injected through the bias transistors, at the price of a larger layout area on silicon. This improvement will be considered for the next versions of the ASIC.

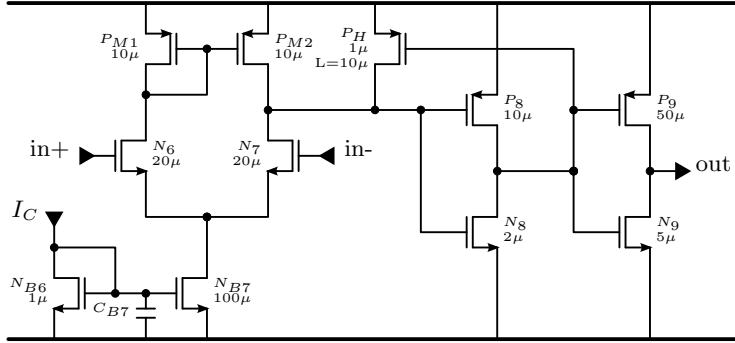

Figure 6: Full schematic of the comparator. The width of the MOS transistors is shown. The gate length is $0.35 \mu\text{m}$ for all the transistors except P_H . The substrate of all NMOS (PMOS) transistors is tied to ground (to the positive rail).

2.2 Design of the comparator

Figure 6 shows the schematic of the comparator. The input stage is a differential pair loaded with a current mirror. This is the only part of the comparator which dissipates a continuous current. Since I_C is about $1 \mu\text{A}$, the differential pair is biased with about $100 \mu\text{A}$. The signal from the CSA is connected to the inverting input of the comparator, while the noninverting input is held at a constant potential which defines the threshold. The threshold voltage at the inverting input of the discriminator can be set between 1.25 V (half the positive rail voltage) and 0.83 V (one third the positive rail voltage) in 32 steps, labelled from 0 to 31, thanks to a 5-bit DAC implemented as a simple voltage divider. Each step is about 13 mV . At the maximum gain, this corresponds to a threshold step of 150 ke^- (24 fC).

In ready state, the output of the differential pair is low, and stays close to 0.5 V . This signal feeds the inverter made of P_8 and N_8 . Transistor N_8 is small and has a large threshold, about 0.6 V . In this way N_8 is biased just below threshold: no current passes through the first inverter and its output is high. Transistor P_H provides hysteresis, and since its gate is high it is switched off. The output of P_8 and N_8 is fed to the second inverter made of P_9 and N_9 , which is also the output stage.

In response to a negative pulse from the CSA, the output of the differential pair goes up, close to the positive rail. The output of first inverter goes to ground, closing the switch P_H , which draws current from the differential pair and holds up its output providing hysteresis. At the same time, the output of P_9 and N_9 swings to the positive rail. The gate length of P_H is large: its “on” resistance is about $150 \text{ k}\Omega$, so that only a fraction of the bias current of the differential pair passes through P_H , and after a few nanoseconds the output of the differential pair is able to get back to the initial condition. When the

output of the differential pair goes down, the output of the first inverter goes up, transistor P_H is opened and the output of the comparator goes down. After this the discriminator is ready to trigger another pulse from the CSA. The width of the output pulses is proportional to the amplitude of the input signals, allowing to apply time over threshold algorithms to determine the input charge and compensate for time walk.

The gain of the input stage of the comparator is about 30 V/V for small signals around threshold at low frequency, with a pole at about 30 MHz. The corresponding time constant is $\tau_C \simeq 5$ ns, about the same as the fall time of the CSA pulse τ_F . The effect of hysteresis is to increase the gain to 600 V/V at low frequency. The gain of the inverters is about 20 V/V for each. The overall gain of the comparator at low frequency including hysteresis results in 24×10^4 V/V or 107 dB. Transistor P_9 is much larger than N_9 , in order to obtain a very fast transition on the rising edge at the output. The rise and fall times of the output signal depend on the load at the output of the discriminator. The output stage was designed to drive only a short line to a digital processing circuit or to an external low impedance driver, located a few cm away on the same board. Thus a purely capacitive load of a few pF is expected. This was done in order to give the maximum flexibility in the design of a full system and to avoid unnecessary power consumption in the CLARO-CMOS. The output signal is limited by the slew rate of the output stage on the output load, that is I_L/C_L , where I_L is the current from the output stage, and C_L is the output load capacitance. The output current can be estimated to be $I_L \simeq 2.5 \text{ V} \times g_9$, where g_9 is the transconductance of the output stage. For small signals, the transconductance of P_9 is 2 mA/V, and that of N_9 is 0.8 mA/V, even if this values are largely non linear since the output stage swings from rail to rail. Anyway the rise time is expected to be about two times smaller than the fall time, since the rising edge is driven by P_9 while the falling edge is driven by N_9 . With these numbers, the time required for the full swing from 0 V to 2.5 V at the output is about $2.5 \text{ V} / (I_L/C_L) \simeq C_L/g_9$. With a load capacitance of $C_L = 8$ pF, for instance, the output 0% to 100% rise time is 4 ns, which corresponds to a 10% to 90% rise time of 3.2 ns, and the output 100% to 0% fall time is 10 ns, which corresponds to a 90% to 10% fall time of 8 ns.

The input transistors N_6 and N_7 have a transconductance g_C of about 700 $\mu\text{A}/\text{V}$, while P_{M1} and P_{M2} have a transconductance g_M of about 300 $\mu\text{A}/\text{V}$. These are the main contributors to the noise of the comparator. Transistor N_{B7} does not contribute because its noise is common mode while the input stage is differential. So in the case of the comparator the bias filtering capacitor C_{B7} can be avoided. The input referred white voltage noise density can be expected to be

$$e_C^2 = 2 \times \frac{8}{3} kT \frac{1}{g_C} + 2 \times \frac{8}{3} kT \frac{g_M}{g_C^2} \simeq \left(6.7 \text{ nV}/\sqrt{\text{Hz}} \right)^2 \quad (6)$$

which together with the $1/f$ contributions corresponds to a voltage noise at the input of about 65 μV RMS. Compared with the RMS noise at the output of the CSA, that is more than 1 mV RMS in the best case of a 3.3 pF input capacitance, this contribution is negligible, at least with the attenuation factor

$B = 1$. With larger attenuations the weight of the noise of the comparator grows accordingly, and at $B = 10$ it becomes significant. Since as already mentioned the attenuation is only meant to be used with very large signals, where the signal to noise ratio is a minor concern, we will anyway consider the case of $B = 1$ in the following. The jitter on the rising edge of the comparator is expressed by

$$\sigma_{\text{Rise}} \simeq \frac{\tau_C}{Q - Q_{TH}} \left(i_n^2 \frac{\tau_C}{8} + e_n^2 C_I^2 \frac{1}{8\tau_C} + A_f C_I^2 \frac{1}{2} \right)^{\frac{1}{2}} \quad (7)$$

The calculations to obtain equation 7 are reported in appendix A.2. The time constant $\tau_C \simeq 5$ ns is given by the bandwidth of the first stage of the comparator. When the threshold is set at 300 ke^- (48 fC), equation 7 predicts a jitter of 32 ps for 600 ke^- (96 fC) signals, of which 24 ps are due to the series noise, and 18 ps to the parallel noise. As for the case of the ENC, the $1/f$ component is negligible. According to equation 7, jitter is expected to decrease to 8 ps for 1.5 Me^- (240 fC) signals. For larger signals, equation 7 predicts an unlimited improvement; in reality the slope of the signal at the first stage of the discriminator is also limited by slew rate. So, in contrast with equation 7, jitter is expected at some point to stop decreasing for larger signals, and to saturate to a constant value.

3 Performance of the prototype

Figure 7 shows the signal at the output of the CSA in “low power” mode, read out at the auxiliary output through the PMOS follower biased with a $1 \text{ k}\Omega$ resistor to the positive rail. The gain was set to the maximum value ($V_3 = V_4 = 0$, $V_F = 1$), and pulses from 330 ke^- (53 fC) to 3.3 Me^- (530 fC) were injected at the input by a Agilent 81130A 600 MHz step generator through a 0.5 pF test capacitance. The 10% to 90% rise time of the test signals is 0.6 ns, simulating the typical charge collection time of a fast photomultiplier. The output of the PMOS follower was buffered with a Texas Instruments LMH6703 fast opamp driving a terminated 50Ω line. The signals were acquired with a Agilent DCA-X 86100D 20 GHz sampling scope with the bandwidth limited to 12 GHz in our measurements.

The leading edge of the measured analog signal in response to a 330 ke^- (53 fC) pulse is 2.8 ns (10% to 90%), its trailing edge is 15.8 ns (90% to 10%), the pulse width at 50% is 8 ns. The corresponding time constants are $\tau_R = 1.3$ ns and $\tau_F = 7.2$ ns. Due to the finite bandwidth of the PMOS follower, the measured signal is slower than the signal at the output of the CSA which feeds the input of the discriminator. Since the transconductance of the PMOS follower is less than 1 mA/V and its bias resistor is $1 \text{ k}\Omega$, the amplitude of the buffered signal is smaller than at the output of the CSA.

The input noise was obtained by measuring the baseline noise at the auxiliary output and referring it to the input of the CSA as an equivalent noise charge (ENC). The measured ENC for an input capacitance of 3.3 pF is 6 ke^- (1 fC) RMS, consistent with equation 3, which predicts 5.6 ke^- (0.89 fC), as already

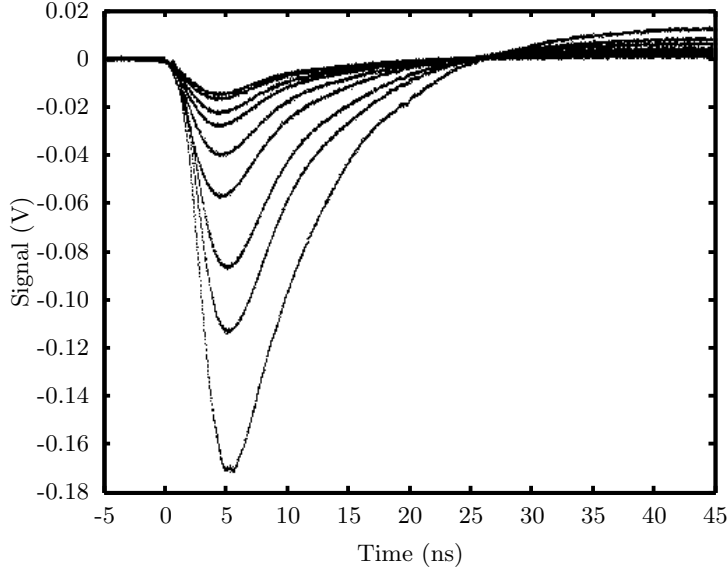

Figure 7: Signals at the output of the analog buffer (auxiliary output) in “low power” mode.

mentioned, once the correct rise and fall time measured at the output of the analog buffer are considered. The importance of low noise is mainly related with timing performance, which will be discussed in the following.

Figure 8 shows the signal at the output of the discriminator when the CLARO-CMOS is operated in “low power” mode. The threshold was set at 6, which at the maximum gain corresponds to 800 ke^- (128 fC), and signals from 810 ke^- (130 fC) to 5.6 Me^- (900 fC) were injected at the input. This range of input signals corresponds to the typical single photon response of a photomultiplier in nominal bias condition. As already mentioned, the output stage of the discriminator is designed to drive a capacitive load of a few pF. In these tests the capacitive load at the output was measured to be 8 pF , contributed by the pads, the QFN48 package, and a short (a few cm) PCB trace to a Texas Instruments LMH6703 fast opamp used as a low impedance driver to the sampling scope. With this load, the 10% to 90% rise time is 2.2 ns , and the 90% to 10% fall time is 9.3 ns . The 50% pulse width depends on the amount of charge injected at the input, ranging from 7.2 ns for the shortest signal in figure 8, that is just above threshold, to 21.7 ns for the largest signal in figure 8, that is almost a factor of 10 above threshold. The delay between the input charge pulse and the time when the output of the discriminator reaches 50% is 5 ns for signals just above threshold, and lowers to about 2.5 ns for signals well above threshold. The delay is due to the rise time of the CSA pulse at the input of the comparator and to the difference in the speed of the comparator for different

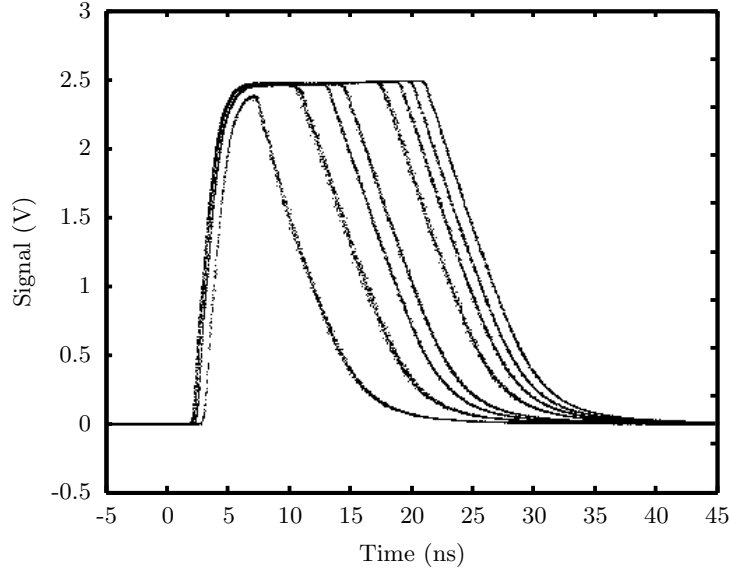

Figure 8: Signals at the output of the discriminator (main output) in “low power” mode.

levels of overdrive. The difference between the two extreme values, about 2.5 ns in “low power” mode, constitutes the time walk of the discriminator, which is critical for timing performance, to be discussed in the following.

This performance was obtained in “low power” mode, with an overall continuous power dissipation per channel of 0.7 mW. If the discriminator is triggered with a 10 MHz rate, the average power consumption increases to 1.9 mW per channel. It is worth noting that the signals in figures 7 and 8 are acquired at the output of the sampling scope: the displayed signals are obtained as the superposition of dots from several output signals, while the sampling trigger was synchronized with the step generator. In this way the figure incorporates at a glance also noise and jitter. The output signals shown demonstrate the capability of the CLARO-CMOS to count fast pulses from photomultipliers, from the single photoelectron up to larger gains, with a low noise, very high rate (up to 10 MHz), and a very low power consumption.

When the prototype is operated in “timing” mode, the power consumption is increased to 1.5 mW per channel (rising to 2.3 mW per channel with a 10 MHz rate). The difference in the output signals between “low power” and “timing” modes are small: the different power consumption affects only the output of the CSA, but the difference cannot be directly appreciated on the shape of the buffered signals because of the bandwidth limitation of the auxiliary output buffer. The differences between the two operating modes can be appreciated on the crosstalk and jitter measurements presented in the following.

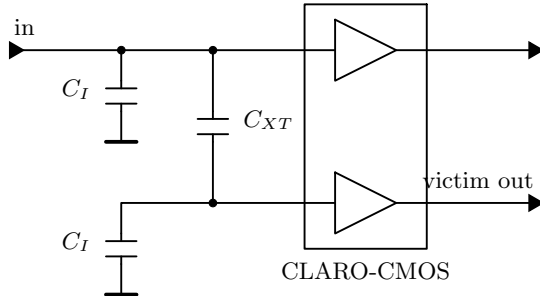

Figure 9: Setup for crosstalk measurement. The capacitance C_{XT} represents the stray capacitance between the pixels of the sensor.

3.1 Crosstalk

With very fast circuits, such as the CLARO-CMOS, crosstalk may be critical. Fast signals could be capacitively coupled to neighbouring channels through parasitic capacitances much more easily than with slower circuits. The level of crosstalk between channels was measured as follows. The gain of the victim channel was set to the maximum value and its threshold was set at 300 ke^- (48 fC). No signal was applied at the input of the victim, while large signals were injected at the input of a neighbouring channel. The crosstalk could be estimated from the amplitude of the minimum signal which triggers the discriminator of the victim. To simulate the real case where different pixels of a pixellated photodetector are connected to the inputs of the CLARO, a crosstalk capacitance C_{XT} was added between the inputs as depicted in figure 9. The input capacitance to ground in this measurement was $C_I = 6.5 \text{ pF}$.

The level of crosstalk was measured with different values of C_{XT} both in “low power” and “timing” modes, and the results are plotted and linearly fitted in figure 10. The crosstalk found on chip, that is with $C_{XT} = 0$, is negligible. Signals up to 10 Me^- (1.6 pC) were injected without triggering the victim. Increasing the value of C_{XT} causes the crosstalk to increase correspondingly. The measured data were fitted with lines, whose intercept value is compatible with zero, confirming that no crosstalk is observed if no capacitance is added outside the ASIC between the inputs. The value of C_{XT} in a given application depends on the type of sensor. For instance, the capacitance between the anodes of a Hamamatsu R7600 Ma-PMT is less than 0.5 pF . This would translate in a crosstalk level below 2% in “low power” mode, and below 1% in “timing” mode. A lower level of crosstalk is obtained in “timing” mode thanks to the lower input impedance, due to the larger loop gain in the CSA as already discussed. For fast readout of pixellated sensors it is mandatory that the parasitic capacitance between neighbouring inputs is kept under control. In the cases where the capacitance C_{XT} cannot be reduced due to the characteristics of the sensor, a larger C_I should be used. This would affect noise and bandwidth, but would

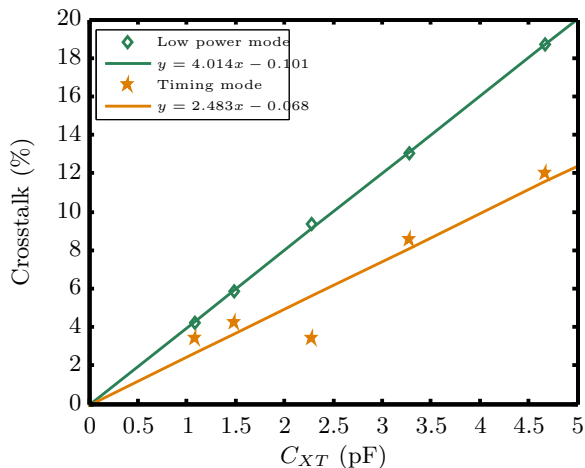

Figure 10: Crosstalk versus crosstalk capacitance C_{XT} in “low power” and “timing” modes.

help in eliminating crosstalk.

3.2 Timing resolution

To evaluate the timing performance of the CLARO-CMOS prototype the gain of the CSA was set to the maximum value, and the threshold of the discriminator was set at 300 ke^- (48 fC). Since the timing performance is expected to be directly proportional to the signal to noise ratio, the use of small input signals corresponds to a conservative, worst case scenario. The time resolution of this setup was estimated to be 7 ps RMS by directly connecting the Agilent 81130A step generator to the Agilent DCA-X 86100D sampling scope. Some of the measurements presented in the following reach 10 ps: in these cases the result is partially limited by the setup. The setup contribution of 7 ps was subtracted in quadrature from the measurements. Moreover, as already mentioned, the 10% to 90% rise time of the input test signals is 0.6 ns, which is not negligible compared to the rise time predicted at the output of the CSA by equation 2 in “timing” mode and with a low input capacitance. As expressed by equation 7, the timing resolution on the rising edge of the discriminator signal is limited by the time constant of the first stage of the comparator τ_C about 5 ns. Thus the contribution of 0.6 ns due to the test signal generator is expected to be negligible in the jitter measurements. It may anyway have some impact on the effectiveness in time over threshold compensation presented in the following.

The overall timing performance of a system composed of a sensor and a low jitter readout circuit depends also on the precision of time walk compensation; otherwise the low jitter would be spoiled by the time walk induced by the amplitude spread of the signals coming from the sensor. Figure 11 shows the

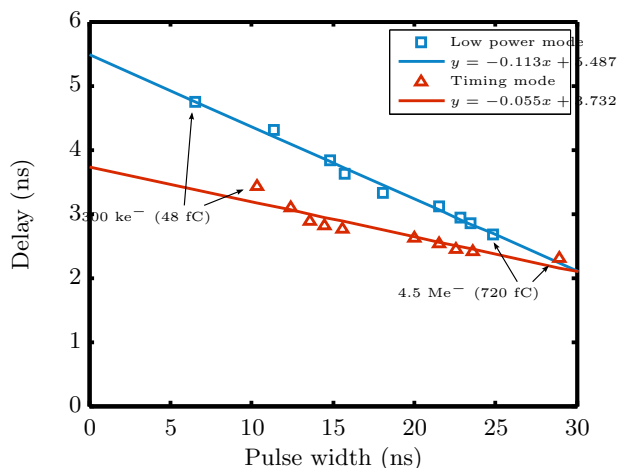

Figure 11: Delay versus pulse width in “low power” and “timing” modes.

dependence of the delay on the pulse width, starting from signals just above threshold. The difference in the delay for a given range of input charge is the time walk of the discriminator. This is the fundamental curve on which the time walk compensation based on time over threshold measurement is based. The slope of the fitting lines can be used to estimate the time over threshold effectiveness in compensating time walk. To a first order approximation, the curves of figure 11 do not depend on threshold. The measurements were taken both in “low power” mode and “timing” mode. In “low power” mode, as already mentioned, the delay ranges from about 5 ns to 2.5 ns, thus the time walk for this range of input signals, that is the difference between the two, is 2.5 ns. In “timing” mode, as shown in figure 11, the time walk of the discriminator reduces by about a factor of 2. Thus, even if the shape of the output signals and the maximum sustainable rate are the same as in “low power” mode, the effectiveness of a time over threshold measurement in compensating time walk is improved by a factor of 2.

The measured RMS jitter versus input charge is displayed in figure 12 for the “low power” mode. The plot shows the jitter on the rising edge, that is 113 ps on threshold (about 300 ke⁻, or 48 fC), decreasing to 34 ps for signals of 560 ke⁻ or 90 fC and then reaching 9 ps for large signals (4.5 Me⁻, or 720 fC). The measured values are in a good match with the values predicted by equation 7. For larger pulses, the rising edge jitter stops decreasing and saturates to a constant value.

The jitter on the falling edge is larger because the transition is slower. Moreover, the jitter on the falling edge is affected by a small disturbance which occurs on ground when the discriminator triggers. This explains the non-monotonic behaviour of the falling edge jitter shown in figure 12. Anyway, the falling edge is only used to compensate time walk: thus the weight of the falling edge jit-

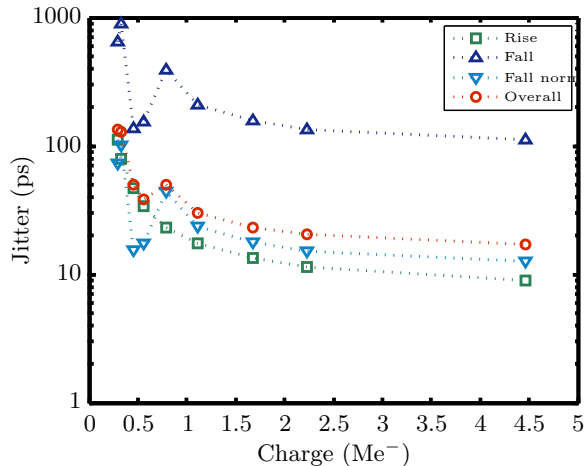

Figure 12: Jitter versus input charge in “low power” mode.

ter on a timing measurement is given by relation between time walk and pulse width, that is the slope γ of the lines used to fit the data in figure 11. In other words, the jitter on the falling edge is normalized according to

$$\sigma_{\text{Fall norm}} = \gamma \sigma_{\text{Fall}} \quad (8)$$

where γ is 0.113 in “low power” mode and 0.055 in “timing” mode, as shown in the legend of figure 11. The jitter on the falling edge normalized with this weight is shown in the plot, and is about 100 ps just above threshold, decreasing to 13 ps with large signals. The overall timing performance (including time walk compensation) is given by the quadratic sum of the rising edge jitter and the normalized falling edge jitter, and is shown in the red curve of figure 12, going from 135 ps just above threshold to 50 ps at 780 ke⁻ (125 fC), furtherly decreasing to 17 ps with 4.5 Me⁻ (720 fC) signals.

The same measurements are given in figure 13 for the “timing” mode. The RMS jitter on the rising edge goes from 92 ps just above threshold (300 ke⁻, or 48 fC) to 10 ps with large signals (4.5 Me⁻, or 720 fC). Now the rise time τ_R of the CSA pulse is smaller than in “low power” mode, so the jitter on the rising edge is a bit smaller than in “low power” mode, but since the speed is in any case limited by the first stage of the discriminator the values are still in agreement with the values predicted by equation 7. Since now the time walk compensation is twice as effective than before, the normalized jitter on the falling edge goes from 44 ps to 6 ps, becoming almost negligible. The overall timing resolution is thus 102 ps just above threshold, quickly decreasing below 50 ps above 380 ke⁻ (61 fC), and ultimately reaching 14 ps for 4.5 Me⁻ (720 fC) signals.

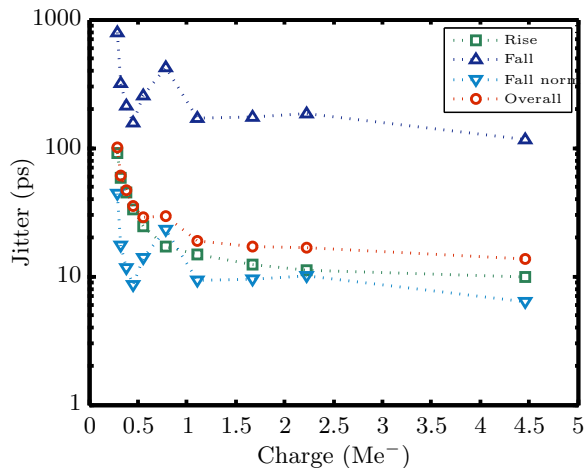

Figure 13: Jitter versus input charge in “timing” mode.

4 Conclusions

The first prototype of the CLARO-CMOS was deeply characterized with a particular emphasis on its timing resolution, also considering the effectiveness of time walk compensation through time over threshold measurement. The prototype performs as expected, proving the adequacy of the design approach described. The obtained time resolution down to 10 ps RMS for input charge pulses corresponding to single photoelectron signals from a typical photomultiplier is outstanding, considering the very low power dissipation of the prototype, below 1 mW per channel.

Acknowledgements

The authors warmly thank Angelo Cotta Ramusino and Roberto Malaguti from INFN Sezione di Ferrara for taking care of the layout and realization of the CLARO-CMOS test board, with which all the characterization and tests presented in this paper were performed.

A Calculations

A.1 Noise

In the complex frequency domain the transfer function of the CSA of figure 3 can be written as

$$\text{TF}_{\text{CSA}}(s) = \frac{1}{sC_F} \frac{s\tau_F}{(1 + s\tau_F)(1 + s\tau_R)} \quad (9)$$

where $s = i\omega$ is the complex frequency, $\tau_F = C_F R_F$, and $\tau_R = C_I / g_2 g_1 R_C$ as given by equation 2. The response to a delta-like pulse $Q\delta(t)$ is obtained by multiplying equation 9 by Q and taking the inverse laplace transform, which gives equation 1. A white current noise density i_n at the input is converted to a voltage noise at the output which is given by

$$V_{O_i}(s) = \frac{i_n}{sC_F} \frac{s\tau_F}{(1 + s\tau_F)(1 + s\tau_R)} \quad (10)$$

A voltage white noise density e_n at the input can be converted to its Norton equivalent, that is a current noise density $sC_I e_n$. The corresponding voltage noise density at the output is

$$V_{O_e}(s) = e_n \frac{C_I}{C_F} \frac{s\tau_F}{(1 + s\tau_F)(1 + s\tau_R)} \quad (11)$$

and the same happens for a voltage low frequency noise A_f/f , which gives

$$V_{O_A}(s) = \frac{A_f}{f} \frac{C_I}{C_F} \frac{s\tau_F}{(1 + s\tau_F)(1 + s\tau_R)} \quad (12)$$

To obtain the squared RMS noise at the output, one must integrate the squared amplitudes of equations 10, 11 and 12 in $d\omega/2\pi$ over the whole frequency spectrum. Equation 10 gives

$$V_{O_i}^2 \text{ RMS} = \frac{i_n^2}{C_F^2} \int_0^\infty \frac{\tau_F^2}{(1 + \omega^2\tau_F^2)(1 + \omega^2\tau_R^2)} \frac{d\omega}{2\pi} = \frac{i_n^2}{C_F^2} \frac{\tau_F^2}{4(\tau_F + \tau_R)} \quad (13)$$

equation 11 gives

$$V_{O_e}^2 \text{ RMS} = e_n^2 \frac{C_I^2}{C_F^2} \int_0^\infty \frac{\omega^2\tau_F^2}{(1 + \omega^2\tau_F^2)(1 + \omega^2\tau_R^2)} \frac{d\omega}{2\pi} = e_n^2 \frac{C_I^2}{C_F^2} \frac{\tau_F^2}{4(\tau_F^2\tau_R + \tau_F\tau_R^2)} \quad (14)$$

and equation 12 gives

$$V_{O_A}^2 \text{ RMS} = A_f \frac{C_I}{C_F} \int_0^\infty \frac{\omega\tau_F^2}{(1 + \omega^2\tau_F^2)(1 + \omega^2\tau_R^2)} d\omega = A_f \frac{C_I}{C_F} \frac{\tau_F^2}{\tau_F^2 - \tau_R^2} \ln \frac{\tau_F}{\tau_R} \quad (15)$$

If one lets $\tau_R \rightarrow \tau_F$ the above expressions reduce to the known expression for a RC-CR filter [16]. In our case $\tau_R \leq 0.3\tau_F$, so we can approximate expanding to the first order in τ_R/τ_F . Equation 13 becomes

$$V_{O_i}^2 \text{ RMS} \simeq \frac{i_n^2}{C_F^2} \frac{\tau_F - \tau_R}{4} \quad (16)$$

equation 14 becomes

$$V_{O_e}^2 \text{ RMS} \simeq e_n^2 \frac{C_I}{C_F} \frac{\tau_F - \tau_R}{4\tau_F\tau_R} \quad (17)$$

and equation 15 becomes

$$V_{OA \text{ RMS}}^2 \simeq A_f \frac{C_I^2}{C_F^2} \ln \frac{\tau_F}{\tau_R} \quad (18)$$

Summing together equations 16, 17 and 18 one obtains the total squared RMS noise at the output:

$$V_O^2 \text{ RMS} \simeq \frac{i_n^2}{C_F^2} \frac{\tau_F - \tau_R}{4} + e_n^2 \frac{C_I^2}{C_F^2} \frac{\tau_F - \tau_R}{4\tau_F\tau_R} + A_f \frac{C_I^2}{C_F^2} \ln \frac{\tau_F}{\tau_R} \quad (19)$$

The square root of equation 19 gives the total RMS noise at the output of the CSA. To obtain the noise referred to the input as ENC one must calculate

$$\text{ENC} = \frac{Q}{V_{O \text{ MAX}}(Q)} V_O \text{ RMS} \quad (20)$$

where $V_{O \text{ MAX}}(Q)$ is the peak output voltage for a charge Q , which can be obtained from equation 1 and is

$$V_{O \text{ MAX}}(Q) = \frac{Q}{C_F} \frac{\tau_F}{\tau_F - \tau_R} \left[\left(\frac{\tau_R}{\tau_F} \right)^{\frac{\tau_R}{\tau_F - \tau_R}} - \left(\frac{\tau_R}{\tau_F} \right)^{\frac{\tau_F}{\tau_F - \tau_R}} \right] \quad (21)$$

which expanding for small τ_R/τ_F becomes

$$V_{O \text{ MAX}}(Q) \simeq \frac{Q}{C_F} \left[1 + \frac{\tau_R}{\tau_F} + \left(\frac{\tau_R}{\tau_F} \right)^2 \right] \left[\left(\frac{\tau_R}{\tau_F} \right)^{\frac{\tau_R}{\tau_F}} \left(1 - \frac{\tau_R}{\tau_F} \right) \right] \simeq \frac{Q}{C_F} \left(1 + \frac{\tau_R}{\tau_F} \ln \frac{\tau_R}{\tau_F} \right) \quad (22)$$

where the expression was approximated using the fact that $x^x \simeq 1 + x \ln x$ for small x , and all the terms in τ_R/τ_F with power equal or higher than 2 were dropped. Equation 22 can be furtherly approximated by

$$V_{O \text{ MAX}}(Q) \simeq \frac{Q}{C_F} \left(1 + 2 \frac{\tau_R}{\tau_F} \right)^{-1} \quad (23)$$

For $\tau_R \ll \tau_F$, both equations give $V_{O \text{ MAX}}(Q) = Q/C_F$. For $\tau_R \leq 0.3\tau_F$, equation 23 approximates equation 22 within a 10% error. For instance, for $\tau_R = \tau_F/e$ equation 22 gives $0.63 Q/C_F$, while equation 23 gives $0.58 Q/C_F$. The approximation of equation 23 is based on the fact that the coefficient 2 is the closest integer to $e/(e-1)$, obtained by imposing the values of equations 22 and 23 to be equal for $\tau_R/\tau_F = 1/e \simeq 0.3$. From equations 19, 20 and 23 one obtains the expression for the squared ENC, that is

$$\text{ENC}^2 \simeq \left(1 + 2 \frac{\tau_R}{\tau_F} \right)^2 \left(i_n^2 \frac{\tau_F - \tau_R}{4} + e_n^2 C_I^2 \frac{\tau_F - \tau_R}{4\tau_F\tau_R} + A_f C_I^2 \ln \frac{\tau_F}{\tau_R} \right) \quad (24)$$

which to the first order in τ_R/τ_F can be also written as

$$\text{ENC}^2 \simeq i_n^2 \frac{\tau_F + 3\tau_R}{4} + e_n^2 C_I^2 \frac{\tau_F + 3\tau_R}{4\tau_F\tau_R} + A_f C_I^2 \frac{\tau_F + 4\tau_R}{\tau_F} \ln \frac{\tau_F}{\tau_R} \quad (25)$$

By taking the square root of equation 25 we obtain equation 3.

A.2 Jitter

To calculate the impact of the noise of the CSA on the timing resolution of the discriminator, one must consider the overall transfer function of the CSA and of the first stage of the comparator when it is triggering, that is when the voltage at the two inputs is almost equal. Neglecting hysteresis the transfer function of the first stage of the comparator in the complex frequency domain can be modelled as $G/(1 + s\tau_C)$. By combining this with equation 9 we obtain the transfer function of the whole chain from the CSA input to the discriminator output, which gives

$$\text{TF}_{\text{TOT}}(s) \simeq \frac{1}{sC_F} \frac{G}{1 + s\tau_C} \frac{s\tau_F}{(1 + s\tau_F)} \quad (26)$$

where equation 9 was approximated for $\tau_R \simeq 0$, since bandwidth is now limited by τ_C , which is expected to be larger than τ_R at least for small values of the input capacitance C_I . As in the case of the squared RMS noise at the output of the CSA alone, which was given by equations 13, 14 and 15, we can calculate the squared RMS noise at the output of the first stage of the discriminator. For a current noise source i_n we obtain

$$V_{O_i \text{ RMS}}^2 = \frac{i_n^2}{C_F^2} G^2 \frac{\tau_F^2}{4(\tau_F + \tau_C)} \simeq \frac{i_n^2}{C_F^2} G^2 \frac{\tau_C}{8} \quad (27)$$

for the voltage white noise

$$V_{O_e \text{ RMS}}^2 = e_n^2 \frac{C_I^2}{C_F^2} G^2 \frac{\tau_F^2}{4(\tau_F^2 \tau_C + \tau_F \tau_C^2)} \simeq e_n^2 \frac{C_I^2}{C_F^2} G^2 \frac{1}{8\tau_C} \quad (28)$$

and for the voltage low frequency noise

$$V_{O_A \text{ RMS}}^2 = A_f \frac{C_I^2}{C_F^2} G^2 \frac{\tau_F^2}{\tau_F^2 - \tau_C^2} \ln \frac{\tau_F}{\tau_C} \simeq A_f \frac{C_I^2}{C_F^2} G^2 \frac{1}{2} \quad (29)$$

where the expressions were approximated for $\tau_C \simeq \tau_F$. The sum of these gives the total RMS noise at the output of the first stage of the discriminator. To obtain the corresponding timing resolution, one must divide the voltage noise by the slope of the signals at the output:

$$\sigma_{\text{Rise}} = \frac{V_{O \text{ RMS}}}{V'_O(t = t_{TH})} \quad (30)$$

where t_{TH} is the time when the second stage of the discriminator triggers the signal. By multiplying equation 26 by the input charge in excess of threshold, that is $Q - Q_{TH}$, then computing its inverse Laplace transform and differentiating it with respect to time, one obtains

$$V'_O(t) = \frac{Q - Q_{TH}}{C_F} G \frac{\tau_F}{\tau_F - \tau_C} \left(\frac{e^{-\frac{t}{\tau_C}}}{\tau_C} - \frac{e^{-\frac{t}{\tau_F}}}{\tau_F} \right) \quad (31)$$

which, considering that $\tau_F \simeq \tau_C$, becomes

$$V'_O(t) = \frac{Q - Q_{TH}}{C_F} G \frac{\tau_C - t}{\tau_C^2} e^{-\frac{t}{\tau_C}} \quad (32)$$

Assuming that the second stage of the discriminator triggers for $t \ll \tau_C$ equation 32 gives

$$V'_O(t = t_{TH}) = \frac{Q - Q_{TH}}{C_F} \frac{G}{\tau_C} \quad (33)$$

By plugging equation 33 together with equations 27, 28 and 29 into equation 30 one obtains

$$\sigma^2_{\text{Rise}} \simeq \frac{1}{(Q - Q_{TH})^2} \left(i_n^2 \frac{\tau_C^3}{8} + e_n^2 C_I^2 \frac{\tau_C}{8} + A_f C_I^2 \frac{\tau_C^2}{2} \right) \quad (34)$$

By taking the square root of equation 34 one obtains equation 7.

References

- [1] F. Anghinolfi, et al., *NINO, an ultrafast, low-power, front-end amplifier discriminator for the Time-Of-Flight detector in ALICE experiment*, IEEE Transactions on Nuclear Science 51 (2004) 1974.
- [2] P. Barrillon, et al., *MAROC: Multi-anode readout chip for MaPMTs*, IEEE Nuclear Science Symposium Conference Record (2006) 809.
- [3] P. Fischer, et al., *Multi-Channel Readout ASIC for ToF-PET*, IEEE Nuclear Science Symposium Conference Record (2006) 2523.
- [4] M. Bouchel, et al., *SPIROC (SiPM Integrated Read-Out Chip): Dedicated very front-end electronics for an ILC prototype hadronic calorimeter with SiPM read-out*, IEEE Nuclear Science Symposium Conference Record (2007) 1857.
- [5] F. Corsi, et al., *BASIC: an 8-channel Front-end ASIC for Silicon Photomultiplier Detectors*, IEEE Nuclear Science Symposium Conference Record (2009) 1082.
- [6] D. Meier, *An ASIC for SiPM/MPPC Readout*, IEEE Nuclear Science Symposium Conference Record (2010) 1653.
- [7] R. Mos, et al., *Front-End electronics for Silicon Photomultiplier detectors implemented in CMOS VLSI integrated circuit*, Electrical Review NR 11a (2010) 79.
- [8] M. Yokoyama, et al., *Radiation Hardness of VA1 with Submicron Process Technology*, IEEE Transactions on Nuclear Science 48 (2001) 440.

- [9] W. Dulinski, et al., *Radiation hardness improved CMOS sensors as particle detectors in high energy physics and medical applications*, IEEE Nuclear Science Symposium Conference Record (2003) 310.
- [10] B. Hosticka, *Improvement of the gain of MOS amplifiers*, IEEE Journal of Solid-State Circuits 14 (6) (1979) 1111.
- [11] W. Sansen, Z. Chang, *Feedforward compensation techniques for high-frequency CMOS amplifiers*, IEEE Journal of Solid-State Circuits 25 (6) (1990) 1590.
- [12] E. Sackinger, W. Guggenbuhl, *A high-swing, high-impedance MOS cascode circuit*, IEEE Journal of Solid-State Circuits 25 (1) (1990) 289.
- [13] R. L. Chase, S. Rescia, *A linear low power remote preamplifier for the Atlas liquid argon EM calorimeter*, IEEE Transactions on Nuclear Science NS-44 (3) (1997) 1028.
- [14] S. Bondil, et al., *Opera_ROC: a front-end chip for opera multi-anode photomultipliers*, IEEE Nuclear Science Symposium Conference Record (2003) 21.
- [15] C. Arnaboldi, et al., *An ultra fast, low power readout chain for single photon sensitivity with multi-anode photomultiplier tubes for the RICH upgrade at LHCb*, Nuclear Instruments and Methods Section A 652 (1) (2011) 487.
- [16] E. Gatti, P. Manfredi, *Processing the signals from solid-state detectors in elementary-particle physics*, Nuovo Cimento 9 (1986) 1.