

A GEOMETRIC TRAPPING APPROACH TO GLOBAL REGULARITY FOR 2D NAVIER-STOKES ON MANIFOLDS

AYNUR BULUT AND KHANG MANH HUYNH

ABSTRACT. In this paper, we use frequency decomposition techniques to give a direct proof of global existence and regularity for the Navier-Stokes equations on two-dimensional Riemannian manifolds without boundary. Our techniques are inspired by an approach of Mattingly and Sinai [15] which was developed in the context of periodic boundary conditions on a flat background, and which is based on a maximum principle for Fourier coefficients.

The extension to general manifolds requires several new ideas, connected to the less favorable spectral localization properties in our setting. Our arguments make use of frequency projection operators, multilinear estimates that originated in the study of the non-linear Schrödinger equation, and ideas from microlocal analysis.

1. INTRODUCTION

Let (M, g) be a closed, oriented, connected, compact smooth two-dimensional Riemannian manifold, and let $\mathfrak{X}(M)$ denote the space of smooth vector fields on M . We consider the incompressible Navier-Stokes equations on M , with viscosity coefficient $\nu > 0$,

$$\begin{cases} \partial_t U + \operatorname{div}(U \otimes U) - \nu \Delta_M U &= -\operatorname{grad} p & \text{in } M \\ \operatorname{div} U &= 0 & \text{in } M \end{cases}, \quad (1)$$

with initial data

$$U_0 \in \mathfrak{X}(M),$$

where $I \subset \mathbb{R}$ is an open interval, and where $U : I \rightarrow \mathfrak{X}(M)$ and $p : I \times M \rightarrow \mathbb{R}$ represent the velocity and pressure of the fluid, respectively. Here, the operator Δ_M is any choice of Laplacian defined on vector fields on M , discussed below.

The theory of two-dimensional fluid flows on flat spaces is well-developed, and a variety of global regularity results are well-known. This includes results on the whole space \mathbb{R}^2 , on smooth bounded domains $\Omega \subset \mathbb{R}^2$, and on the square $(0, 1)^2$ with periodic boundary conditions, which corresponds to the flat torus \mathbb{T}^2 . Important results in this direction are due to Ladyzhenskaya [13], and Fujita-Kato [8], with the latter analysis being based on estimates for the heat semigroup.

In [15], Mattingly and Sinai give an elementary proof of regularity (and in fact analyticity) for the periodic setting – see also the references cited in [15] for a summary of other related results. The technique in [15] works directly with sequences of Fourier coefficients. They establish a priori bounds for the two-dimensional flow by

appealing to a Galerkin method and invoking a variant of the maximum principle applied to the system of ODEs for the Fourier coefficients.

In this paper, we develop and extend this *geometric trapping* method to the case of the Navier-Stokes system posed on a general manifold M satisfying conditions as above.

The study of fluid equations such as (1) posed on manifolds has a long history. In addition to the physical motivation, where fluid models posed on surfaces such as the sphere emerge naturally as we consider atmospheric models of the Earth, the PDEs of fluids are intimately tied to geometry. The interplay between geometry and analysis arising in the study of fluid dynamics has inspired new developments in many directions. This includes applications to Hodge theory, the Euler-Arnold equation, Leray's sheaf theory, Killing vector fields, and other areas. We refer interested readers to [1, 7, 5, 6, 12, 16, 20, 11] and the references contained in these works.

Before proceeding, we elaborate on the choice of the vector Laplacian Δ_M . Due to the influence of curvature, there are essentially three canonical choices for the vector Laplacian,

- the Hodge-Laplacian $\Delta_H = -(d\delta + \delta d)$, which is defined on differential forms, and then extended to vector fields by the musical isomorphism,
- the connection Laplacian (or *Bochner Laplacian*) $\Delta_B T := \text{tr}(\nabla^2 T) = \nabla_i \nabla^i T$ for any tensor T (note that, by the Weitzenböck formula, which we recall in Appendix A, we have $\Delta_B X = \Delta_H X + \text{Ric}(X)$ for all smooth vector fields X on M), and
- the deformation Laplacian $\Delta_D X = -2 \text{Def}^* \text{Def} X = 2 \text{div} \text{Def} X$ where $(\text{Def} X)^{ij} = \frac{1}{2} (\nabla^i X^j + \nabla^j X^i)$ for $X \in \mathfrak{X}(M)$. Then, for all smooth vector fields X , $\Delta_D X = \Delta_H X + 2 \text{Ric}(X) + \text{grad} \text{div} X$. Since $\text{div} U = 0$ in the Navier-Stokes equation, we can treat Δ_D as $\Delta_H + 2 \text{Ric}$ for the incompressible Navier-Stokes equation.

Each of the operators Δ_H , Δ_B , and Δ_D have the same principal symbol (or leading terms), and so our treatment is largely independent of the specific choice of Δ_M . In the context of fluid models on manifolds, the Hodge Laplacian was used in [5, 12], while the deformation Laplacian was preferred in more recent works such as [20, 3, 16, 17]. We use the convention that all three operators are negative definite, to be consistent with the scalar Laplacian (that is, the Laplace-Beltrami operator $\Delta f = \Delta_H f = \text{div} \text{grad} f = \nabla^i \nabla_i f$).

We are now ready to state our main result.

Theorem 1. *Let (M, g) be a closed, oriented, connected, compact smooth two-dimensional Riemannian manifold, and let Δ_M be any of the vector Laplacian operators Δ_H , Δ_B , or Δ_D on M .*

Suppose that $U_0 \in \mathfrak{X}(M)$. Then there exists a unique global-in-time smooth solution $U : \mathbb{R} \rightarrow \mathfrak{X}(M)$ to (1) with $U(0) = U_0$.

As we mentioned above, to prove Theorem 1, we will extend and develop the geometric trapping ideas that originated in the setting of the two-dimensional torus in [15]. In fact, our methods give sharper information about the regularity of solutions than what we have stated; we choose to state the basic smoothness claim to focus on the essential aspects of the argument.

In our setting, a number of subtleties arise that require new ideas beyond the treatment in [15], even in the case of the sphere $S^2 \subset \mathbb{R}^3$. To illustrate this, one can ask whether replacing $e^{i2\pi\langle k, z \rangle}$ with spherical harmonics (the eigenfunctions on the sphere) would extend the result to the sphere. However, such an approach will not work directly. This is because of the poor spectral localization of products on the sphere (unlike $e^{i2\pi\langle k_1, z \rangle} e^{i2\pi\langle k_2, z \rangle} = e^{i2\pi\langle k_1 + k_2, z \rangle}$ for the torus). At most, the resulting frequency will lie in a region defined by triangle inequalities. Moreover, the L^2 estimate of the product suffers from an extra factor $\min(k_1, k_2)^{\frac{1}{4}}$, which is essentially sharp on the sphere. This will lead to an unacceptable loss of decay in summing the frequencies.

Instead, we follow a different approach. We will group eigenfunctions with the same eigenvalue together, and work with eigenspace projections instead of Fourier coefficients. We will also replace the non-optimal use of Hölder's inequality in the bounds by multilinear estimates from the theory of non-linear Schrödinger equations [2]. Combining this with a few additional technical tools, we gain enough decay to obtain geometric trapping in the case when M is the sphere $S^2 \subset \mathbb{R}^3$.

For general compact manifolds, the situation is even more complicated. The spectral localization of products is poorer (with no triangle inequalities), the Ricci tensor is no longer constant, and there can be non-trivial harmonic 1-forms. To handle the non-triangle regions, we extend some estimates from [9], generalizing the argument to handle more derivatives as needed in our setting.

To handle the extra terms coming from the Ricci tensor, we use an integration by parts argument as in the method of stationary phase. To avoid dealing with the distribution of eigenvalues on manifolds, we use frequency cutoffs as defined by the functional calculus of the Laplacian. The passage between eigenspace projections and frequency cutoffs for multilinear estimates is made possible by a Fourier decomposition technique.

Outline of the paper. In Section 2, we recall our notation and give a preliminary derivation of the precise formulation of the Navier-Stokes system (1) that we will use in our analysis, including the construction of a sequence of Galerkin projections, for which we will establish a priori bounds.

The global regularity results of Theorem 1 will follow from a priori bounds for this system (independent of the projection); we establish these in Section 3, where we formulate the geometric trapping construction, and Section 4, which contains the main estimates that allow us to take full advantage of the diffusive effect of the viscosity term.

Acknowledgments. We are very grateful to Terence Tao, Yakov Sinai, and Zaher Hani for valuable discussions during the preparation of this work.

2. NOTATION AND PRELIMINARIES

In this section, we establish our notation, and derive the main formulation of the Navier-Stokes system (posed on the manifold M) that we will use in our analysis. In particular, after recalling our notation and introducing a relevant class of frequency cutoff and projection operators in Sections 2.1 and 2.2, we formulate the system in terms of an equation for the *vorticity* (see Section 2.4), and introduce a sequence of Galerkin projections (see Section 2.5), along with some preliminary analysis of the relevant a priori estimates for the system.

2.1. Geometric notation & review. Unless mentioned otherwise, the metric g is the Riemannian metric, and the connection ∇ is the Levi-Civita connection. We write $\langle \cdot, \cdot \rangle$ to denote the Riemannian fiber metric for tensor fields on M . We also define the dot product

$$\langle\langle \sigma, \theta \rangle\rangle = \int_M \langle \sigma, \theta \rangle \text{vol}$$

where σ and θ are tensor fields of the same type, while vol is the Riemannian volume form. When there is no possible confusion, we will omit writing vol .

Let $\Omega^1(M)$ denote the space of 1-forms on M . As usual, for any smooth vector field $X \in \mathfrak{X}(M)$, we define $X^\flat \in \Omega^1(M)$, also denoted by $\flat X$, by setting $X^\flat(Y) := \langle X, Y \rangle$ for $Y \in \mathfrak{X}(M)$. This is the so-called *musical isomorphism*, which identifies $\mathfrak{X}(M)$ with $\Omega^1(M)$. Similarly, we define $\langle \alpha^\sharp, Y \rangle = \alpha(Y)$ for any $\alpha \in \Omega^1(M)$ and $Y \in \mathfrak{X}(M)$.

As in [11], we will often use *Penrose abstract index notation* (cf. [21, Section 2.4]), where the indices do not correspond to any preferred coordinate system, but only indicate the types of tensors and how they contract. This should not be confused with the similar-looking Einstein notation for local coordinates, or the similar-sounding Penrose graphical notation. We collect the usual identities in differential geometry (proved in [14] and [21]), expressed in Penrose notation, in Appendix A.

We conclude this section by recalling some conventions and common notation used throughout the rest of this paper. We will write $A \lesssim_{x,-y} B$ for $A \leq CB$, where C is a positive constant depending on x and not y . Similarly, $A \sim_{x,-y} B$ means $A \lesssim_{x,-y} B$ and $B \lesssim_{x,-y} A$. We will omit the explicit dependence when it is either not essential or obvious by context.

With $\Omega^k(M)$, $k \geq 1$, denoting the space of k -forms on M , we recall the usual Hodge star operator $\star : \Omega^k(M) \xrightarrow{\sim} \Omega^{n-k}(M)$, the exterior derivative $d : \Omega^k(M) \rightarrow \Omega^{k+1}(M)$, the codifferential $\delta : \Omega^k(M) \rightarrow \Omega^{k-1}(M)$, and the Hodge Laplacian $\Delta = -(d\delta + \delta d)$ (cf. [19, Section 2.10] and [18, Definition 1.2.2]). We note that d is the operator that appears in Stokes' theorem, and remark that δ is the L^2 -adjoint of d ; moreover, $\delta(X^\flat) = -\text{div}_g X$ for $X \in \mathfrak{X}(M)$.

Throughout the paper, we will use the notation D^k as a “schematic” for a spatial differential operator of order k , with coefficients bounded in the C^∞ topology for all time. In each setting where this appears, results from microlocal analysis (or just straight calculations) then give the schematic identities

$$[D^k, D^l] = D^{k+l-1},$$

when $\sigma(D^k) \circ \sigma(D^l) = \sigma(D^l) \circ \sigma(D^k)$ (e.g., when D^k is a Laplace-type operator), and

$$\langle \langle D^k \phi, \psi \rangle \rangle = \langle \langle \phi, D^k \psi \rangle \rangle,$$

for smooth tensor fields ϕ and ψ .

2.2. Frequency cutoff and projection operators. As the Laplace-Beltrami operator Δ is self-adjoint, we can define its functional calculus by the spectral theorem (see [19, Section A.8]). For any $s \in \sigma(\sqrt{-\Delta})$, define $\pi_s : \mathcal{D}'(M) \rightarrow C^\infty(M)$ as the continuous eigenspace projection mapping into the space of eigenfunctions corresponding to s . So $(-\Delta)\pi_s = s^2\pi_s$ on $\mathcal{D}'(M)$. In particular, the image of π_0 is the space of constant functions.

We also define the frequency cutoff projections

$$P_k = 1_{[k, k+1)}(\sqrt{-\Delta}) = \sum_{s \in \sigma(\sqrt{-\Delta}) \cap [k, k+1)} \pi_s, \quad k > 0,$$

and, for $k, m \in \mathbb{N}_0$, we define

$$\begin{aligned} \mathcal{P}_1 &: H^m \Omega^k(M) \rightarrow d(H^{m+1} \Omega^{k-1}(M)), \\ \mathcal{P}_2 &: H^m \Omega^k(M) \rightarrow \delta(H^{m+1} \Omega^{k-1}(M)), \end{aligned}$$

and

$$\mathcal{P}_3 = \mathcal{P}_{\mathcal{H}} : \mathcal{D}' \Omega^k(M) \rightarrow \Omega^k(M),$$

as the continuous Hodge projections. As in [11], we have $1 = \mathcal{P}_1 + \mathcal{P}_2 + \mathcal{P}_3$, and remark that

$$\mathbb{P} := \mathcal{P}_2 + \mathcal{P}_3$$

is the classical Leray projection operator.

Note that the range of $\mathcal{P}_{\mathcal{H}}$ is finite-dimensional (with $\mathcal{P}_{\mathcal{H}} = \pi_0$ on $\Omega^0(M)$), which is essentially the frequency zero. The foundational result of Hodge theory is that for any $m \in \mathbb{N}_0$ and $k \in \mathbb{N}_0$, Δ_H is bijective from $(1 - \mathcal{P}_{\mathcal{H}})H^{m+2}\Omega^k(M)$ to $(1 - \mathcal{P}_{\mathcal{H}})H^m\Omega^k(M)$. It follows from this that $(-\Delta_H)^{-1}$ is well-defined on $(1 - \mathcal{P}_{\mathcal{H}})H^m\Omega^k(M)$. We also easily see that $\mathcal{P}_{\mathcal{H}}\star = \star\mathcal{P}_{\mathcal{H}}$.

We can extend $\mathcal{P}_{\mathcal{H}}, \mathcal{P}_1, \mathcal{P}_2$ to vector fields via the musical isomorphism on 1-forms. We can also define the frequency cutoffs P_k on differential forms (and vector fields) by invoking the functional calculus of Δ_H .

Then $P_k d = dP_k$, $P_k \delta = \delta P_k$, $P_k \Delta_H = \Delta_H P_k$, $P_k \star = \star P_k$, $P_k \mathcal{P}_i = \mathcal{P}_i P_k$ for $i = 1, 2, 3$. In particular, $P_k \mathcal{P}_{\mathcal{H}} = 0$ for any $k > 0$.

Let λ_1 denote the smallest nonzero mode; that is,

$$\lambda_1 = \lambda_1(M) := \min(\sigma(\sqrt{-\Delta_H}) \setminus \{0\}), \quad (2)$$

where Δ_H is treated as an unbounded operator on

$$L^2\Omega(M) := \oplus_{s=0}^2 L^2\Omega^s(M).$$

Then, for all $m \in \mathbb{N}_0$, we can replace the H^m norm on forms by

$$\begin{aligned} \|\theta\|_{H^m} &= \|\mathcal{P}_{\mathcal{H}}\theta\|_{L^2} + \|k^m\|_{L^2} \|P_k\theta\|_{L^2} \|\ell_k^2(\mathbb{N}_0 + \lambda_1) \\ &\sim \|\mathcal{P}_{\mathcal{H}}\theta\|_{L^2} + \|(-\Delta_H)^{m/2}(1 - \mathcal{P}_{\mathcal{H}})\theta\|_{L^2}. \end{aligned}$$

2.3. The vector Laplacian operator. We now make a few remarks related to the choice of the Laplacian operator Δ_M as either the Hodge Laplacian Δ_H , the connection (Bochner) Laplacian Δ_B , or the deformation Laplacian Δ_D .

The choice of this operator in the Navier-Stokes system (1) affects the class of initial data that one can consider to obtain global results by perturbing the classical flat background theory. For instance, if we choose the Hodge-Laplacian, the ‘‘global existence for small data’’ result on flat spaces will generalize to initial data near the space of harmonic vector fields (satisfying $\Delta_H X = 0$). On the other hand, if we choose the deformation Laplacian, then, as proved in [17], the flat background small data theory leads to results for initial data in small neighborhoods of the space of *Killing vector fields*, which satisfy the equation $\Delta_D X = 0$. Both spaces are finite-dimensional and algebraically rigid, leading to their own respective theories.

Nevertheless, for the results of this paper, we may take Δ_M to be any of these three choices. Indeed, our arguments will rely on the following properties, which are valid for all three operators:

- (i) $\Delta_M = \Delta_H + F$ where F is a differential operator of order 0 (with smooth coefficients),
- (ii) Δ_M is self-adjoint on $L^2\mathfrak{X}(M)$, and
- (iii) $\Delta_M \leq 0$.

Note that condition (iii) amounts to a choice of convention for signs, and corresponds to the physical dissipation of energy.

2.4. The vorticity equation. Consider the Navier-Stokes equation as in (1). For $f \in C^\infty(M)$, define $\text{curl } f = -(\star df)^\sharp$. Because we are in two spatial dimensions, we have $dU^b = \omega \text{vol}$ for some $\omega \in C^\infty(M)$. The *vorticity* ω is then defined by setting

$$\omega := \star dbU = \star d\mathcal{P}_2 bU.$$

The advantage of working in two spatial dimensions is that the vorticity can be identified with a scalar function, and we can control its L^2 norm (via the enstrophy estimate). It is trivial to check that $d : \mathcal{P}_2\Omega^1(M) \rightarrow \mathcal{P}_1\Omega^2(M)$ is bijective with inverse $R_d = \delta(-\Delta_H)^{-1} = (-\Delta_H)^{-1}\delta$, so $\mathcal{P}_2 bU = \delta(-\Delta_H)^{-1}\star\omega = -\star d(-\Delta)^{-1}\omega$. Moreover, $\pi_0\omega = 0$, and, since $U = \mathbb{P}U$,

$$(1 - \mathcal{P}_{\mathcal{H}})U = \mathcal{P}_2 U = \text{curl}(-\Delta)^{-1}\omega.$$

We use these identities to reformulate the system (1) in terms of ω . For this, we begin with a lemma relating the Lie derivative and the musical isomorphism.

Lemma 2. *Let X be a smooth vector field on M . Then*

$$\mathcal{L}_X X^b = \nabla_X X^b + d\left(\frac{|X|^2}{2}\right).$$

Proof. We compute, for any smooth vector field $Y \in \mathfrak{X}(M)$,

$$\begin{aligned} (\mathcal{L}_X X^b)(Y) &= \mathcal{L}_X \langle X, Y \rangle - \langle X, [X, Y] \rangle \\ &= \langle \nabla_X X, Y \rangle + \langle X, \nabla_X Y - [X, Y] \rangle \\ &= \langle \nabla_X X, Y \rangle + \langle X, \nabla_Y X \rangle \\ &= (\nabla_X X^b) \cdot Y + d\left(\frac{|X|^2}{2}\right) \cdot Y. \end{aligned}$$

This completes the proof of the lemma. \square

We apply the musical isomorphism to the Navier-Stokes equation. In view of Lemma 2, this gives

$$0 = \partial_t U^b + \mathcal{L}_U U^b - \nu(\Delta_H + F)U^b + d\left(p - \frac{|U|^2}{2}\right).$$

Now, an application of the exterior derivative leads to

$$0 = \partial_t \omega \operatorname{vol} + (\mathcal{L}_U \omega) \operatorname{vol} + \omega(\operatorname{div} U) \operatorname{vol} - \nu(\Delta \omega \operatorname{vol} + dFbU),$$

which, using $\operatorname{div} U = 0$, becomes

$$\begin{aligned} 0 &= \partial_t \omega + \langle U, \nabla \omega \rangle - \nu \Delta \omega - \nu \star dFbU \\ &= \partial_t \omega + \left\langle \operatorname{curl}(-\Delta)^{-1} \omega, \nabla \omega \right\rangle + \langle \mathcal{P}_{\mathcal{H}} U, \nabla \omega \rangle \\ &\quad - \nu \Delta \omega - \nu \star dFb \left(\operatorname{curl}(-\Delta)^{-1} \omega + \mathcal{P}_{\mathcal{H}} U \right). \end{aligned}$$

Because ω only governs $(1 - \mathcal{P}_{\mathcal{H}})U$, we cannot completely remove the coupling with the velocity equation. Fortunately, $\|U\|_{L^2}$ stays bounded (in view of the energy inequality), so $\|\mathcal{P}_{\mathcal{H}} U\|_{C^m} \lesssim_m \|U\|_{L^2}$ stays bounded for all $m \in \mathbb{N}_0$. This means that the harmonic part is relatively easy to control.

Collecting these arguments, we have arrived at the following equivalent formulation of the Navier-Stokes system:

$$\begin{cases} U &= \mathcal{P}_{\mathcal{H}} U + \operatorname{curl}(-\Delta)^{-1} \omega \\ 0 &= \partial_t \omega + \left\langle \operatorname{curl}(-\Delta)^{-1} \omega, \nabla \omega \right\rangle + \langle \mathcal{P}_{\mathcal{H}} U, \nabla \omega \rangle \\ &\quad + \nu D^2(-\Delta)^{-1} \omega + \nu D^1 \mathcal{P}_{\mathcal{H}} U - \nu \Delta \omega \\ 0 &= \partial_t \mathcal{P}_{\mathcal{H}} U + \mathcal{P}_{\mathcal{H}} \nabla_U U + \nu \mathcal{P}_{\mathcal{H}} D^0 U \end{cases} \quad (3)$$

We note that the condition $\operatorname{div} U = 0$ is already implied, and operators implied within D^2, D^1, D^0 can be explicitly written out.

2.5. Galerkin approximation and a priori estimates. Let λ_1 be the smallest nonzero mode as in (2), and let $Z \subset \mathbb{N}_0 + \lambda_1$ be a finite subset selecting the modes

included in the Galerkin approximation

$$\omega_Z = \sum_{k \in Z} P_k \omega_Z.$$

Then the truncated equation is

$$\begin{cases} U_Z = \mathcal{P}_{\mathcal{H}} U_Z + \operatorname{curl}(-\Delta)^{-1} \sum_{k \in Z} P_k \omega_Z, \\ 0 = \partial_t P_k \omega_Z + \sum_{l_1, l_2 \in Z} P_k \left\langle \operatorname{curl}(-\Delta)^{-1} P_{l_1} \omega_Z, \nabla P_{l_2} \omega_Z \right\rangle \\ \quad + \sum_{l \in Z} P_k \langle \mathcal{P}_{\mathcal{H}} U_Z, \nabla P_l \omega_Z \rangle + \sum_{l \in Z} \nu P_k D^2 (-\Delta)^{-1} P_l \omega_Z \\ \quad + \nu P_k D^1 \mathcal{P}_{\mathcal{H}} U_Z - \nu \Delta P_k \omega_Z, \quad \forall k \in Z, \\ 0 = \partial_t \mathcal{P}_{\mathcal{H}} U_Z + \mathcal{P}_{\mathcal{H}} \nabla_{U_Z} U_Z + \nu \mathcal{P}_{\mathcal{H}} D^0 U_Z. \end{cases} \quad (4)$$

A more explicit form, without D^2, D^1, D^0 , is

$$\begin{cases} U_Z = \mathcal{P}_{\mathcal{H}} U_Z + \operatorname{curl}(-\Delta)^{-1} \omega_Z, \\ 0 = \partial_t \omega_Z + P_Z \nabla_{U_Z} \omega_Z - \nu P_Z \star d\Delta_M \flat U_Z, \\ 0 = \partial_t \mathcal{P}_{\mathcal{H}} U_Z + \mathcal{P}_{\mathcal{H}} \nabla_{U_Z} U_Z - \nu \mathcal{P}_{\mathcal{H}} \Delta_M U_Z, \end{cases} \quad (5)$$

where $P_Z := \sum_{k \in Z} P_k$.

Selecting a finite basis for $\operatorname{Range}(\mathcal{P}_{\mathcal{H}})$ and $\operatorname{Range}(P_k)$ for each k , we obtain a smooth finite-dimensional ODE system (with the unknowns being an analogue of the sequence of Fourier coefficients, depending only on time).

This system has a smooth solution on $[0, T_Z)$ for some $T_Z \in (0, \infty]$ (by Picard's theorem). Standard Hodge theory now shows that the solution U_Z solves a truncated form of the Navier-Stokes equation.

Lemma 3. *Let $Z \subset \mathbb{N}_0 + \lambda_1$ be a finite set. Suppose that U_Z solves (5). Then U_Z is also a solution to the equation*

$$\partial_t U_Z + (\mathcal{P}_{\mathcal{H}} + P_Z \mathcal{P}_2) \nabla_{U_Z} U_Z - \nu (\mathcal{P}_{\mathcal{H}} + P_Z \mathcal{P}_2) \Delta_M U_Z = 0. \quad (6)$$

Proof. We have $\omega_Z = \star db U_Z$ and

$$\begin{aligned} -\partial_t U_Z &= -\partial_t \mathcal{P}_{\mathcal{H}} U_Z - \operatorname{curl}(-\Delta)^{-1} \partial_t \omega_Z \\ &= \mathcal{P}_{\mathcal{H}} \nabla_{U_Z} U_Z - \nu \mathcal{P}_{\mathcal{H}} \Delta_M U_Z \\ &\quad + \operatorname{curl}(-\Delta)^{-1} (P_Z \nabla_{U_Z} \omega_Z - \nu P_Z \star d\Delta_M \flat U_Z). \end{aligned}$$

In view of this, we want to show

$$\mathcal{P}_2 (P_Z \nabla_{U_Z} U_Z - \nu P_Z \Delta_M U_Z) = \operatorname{curl}(-\Delta)^{-1} (P_Z \nabla_{U_Z} \omega_Z - \nu P_Z \star d\Delta_M \flat U_Z)$$

We showed above that $\operatorname{curl}(-\Delta)^{-1} : \mathcal{P}_2 \Omega^0 \rightarrow \mathcal{P}_2 \mathfrak{X}$ is bijective with inverse $\star db$. Also $d\mathcal{P}_2 = d$, so now we only need to show

$$\star db (P_Z \nabla_{U_Z} U_Z - \nu P_Z \Delta_M U_Z) = P_Z \nabla_{U_Z} \omega_Z - \nu P_Z \star d\Delta_M \flat U_Z$$

For this, note that by Lemma 2, we have

$$\begin{aligned} \star db P_Z \nabla_{U_Z} U_Z &= P_Z \star d\mathcal{L}_{U_Z} \flat U_Z \\ &= P_Z \star \mathcal{L}_{U_Z} db U_Z \end{aligned}$$

$$\begin{aligned}
 &= P_Z \star \mathcal{L}_{U_Z} (\omega_Z \text{ vol}) \\
 &= P_Z \star ((\nabla_{U_Z} \omega_Z) \text{ vol}) \\
 &= P_Z \nabla_{U_Z} \omega_Z,
 \end{aligned}$$

which completes the proof. \square

We aim to take the limit $Z \uparrow \mathbb{N}_0$. In order to obtain convergence, we will need a priori estimates that are independent of the truncation set Z . The first such estimate is the *energy inequality*,

$$\|U_Z(t)\|_{L^2} \leq \|U_Z(0)\|_{L^2},$$

which follows from (6) and the fact that $\Delta_M \leq 0$. In particular, the energy estimate implies that $\mathcal{P}_{\mathcal{H}} U_Z(t)$ stays bounded in the C^∞ topology.

The second a priori estimate we will use is the *enstrophy estimate*,

$$\|\omega_Z(t)\|_{L^2} \lesssim_{-Z} (\|\omega_Z(0)\|_{L^2} + \|U_Z(0)\|_{L^2}) e^{\nu C t}, \quad (7)$$

which we will show holds for some C depending only on M , not Z . Indeed, observe that

$$\begin{aligned}
 0 &= \langle \langle \partial_t \omega_Z, \omega_Z \rangle \rangle + \langle \langle \nabla_{U_Z} \omega_Z, \omega_Z \rangle \rangle - \nu \langle \langle \star d(\Delta_H + F) \flat U_Z, \omega_Z \rangle \rangle \\
 &= \partial_t \left(\frac{\|\omega_Z\|_2^2}{2} \right) - \nu \langle \langle \star d \Delta_H \flat U_Z, \star d \flat U_Z \rangle \rangle - \nu \langle \langle D^1 U_Z, \omega_Z \rangle \rangle \\
 &= \partial_t \left(\frac{\|\omega_Z\|_2^2}{2} \right) + \nu \langle \langle \Delta_H \flat U_Z, \Delta_H \flat U_Z \rangle \rangle - \nu \langle \langle D^1 U_Z, \omega_Z \rangle \rangle,
 \end{aligned}$$

and thus $\partial_t \left(\|\omega_Z\|_2^2 \right) \lesssim \nu \|\omega_Z\|_2 \|U_Z\|_{H^1}$. But, by the Poincare inequality [11],

$$\|U_Z\|_{H^1} \sim_M \|\mathcal{P}_{\mathcal{H}} U_Z\|_2 + \|\delta \flat U_Z\|_2 + \|d \flat U_Z\|_2 \lesssim \|U_Z(0)\|_2 + \|\omega_Z\|_2.$$

So we have

$$\begin{aligned}
 \partial_t \left(\|\omega_Z(t)\|_2^2 + \|U_Z(0)\|_2^2 \right) &\lesssim \nu (\|\omega_Z(t)\|_2 + \|U_Z(0)\|_2)^2 \\
 &\sim \nu \left(\|\omega_Z(t)\|_2^2 + \|U_Z(0)\|_2^2 \right).
 \end{aligned}$$

An application of Gronwall's inequality now gives the enstrophy estimate (7).

Remark 4. As a particular consequence, note that by Picard's theorem and the fact that modes are finite, the above bounds show that $T_Z = \infty$ and that U_Z exists globally in time.

Note that the enstrophy is non-increasing when $\Delta_M = \Delta_H$ ($F = 0$). This is the case for flat spaces.

The main a priori estimate for smooth convergence we establish in this paper is the following theorem.

Theorem 5. *If for some $A_0 \in (0, \infty)$ and $r > 1$,*

$$\|U_Z(0)\|_2 \leq A_0 \quad \text{and} \quad \|P_k \omega_Z(0)\|_2 \leq \frac{A_0}{|k|^r} \quad \forall k \in Z,$$

then

$$\|P_k \omega_Z(t)\|_2 \leq \frac{A^*(t)}{|k|^r} \quad \forall t \geq 0, \forall k \in Z$$

for some smooth $A^*(t)$ depending on r, ν, M, A_0 and not Z .

Note that the hypotheses of Theorem 5 implicitly yield

$$\|w_Z(0)\|_2 \lesssim A_0 \left\| \frac{1}{k^r} \right\|_{l_k^2} \lesssim_{-Z} A_0.$$

We prove Theorem 5 in Section 3 and Section 4 below; indeed, this is the main task of the rest of this paper.

Assume that we have established Theorem 5. We now show how to conclude the proof of our Theorem 1, our main result on global regularity for solutions to the Navier-Stokes system (1) on M . To leverage the a priori bounds of Theorem 5, we begin with a short uniqueness lemma for the class of smooth solutions.

Lemma 6. *Any smooth solution to Navier-Stokes must be unique.*

Proof. Let U and $U + V$ be 2 smooth solutions with the same initial data (i.e. $V(0) = 0$). Then $0 = \partial_t V + \mathbb{P}(\nabla_V U + \nabla_{U+V} V) - \nu \Delta_M V$, which implies

$$\partial_t \left(\frac{\|V\|_2^2}{2} \right) = - \langle \nabla_V U, V \rangle + \nu \langle \Delta_M V, V \rangle \leq \|V\|_2^2 \|\nabla U\|_\infty$$

As $V(0) = 0$, by Gronwall $V = 0$. □

We now complete the proof of Theorem 1.

Proof of Theorem 1. Suppose U_0 is smooth. Then, choosing any $r > 1$, we may apply Theorem 5 to see that the sequence (U_Z) remains bounded in $C_{t,\text{loc}} H_x^\infty$ as the truncation set Z expands to $\mathbb{N}_0 + \lambda_1$.

Using the usual exchange of one time derivative for spatial derivatives in our Navier-Stokes system, we therefore obtain uniform bounds in $C_{t,\text{loc}}^\infty H_x^\infty$. By the Sobolev embedding, it follows that there is a subsequence $(U_{Z_i})_{i \geq 0}$ converging to a smooth solution U (as P_Z is a contraction on all H^m).

This shows that there exists a global smooth solution with initial data U_0 . In view of the uniqueness result for solutions of this class given in Lemma 6, the proof of the global regularity result is complete. □

3. GEOMETRIC TRAPPING

In this section and Section 4, we prove Theorem 5. As described in the introduction, the argument follows the general pattern of the geometric trapping method of [15]. In our setting, this requires several additional ideas, due to the less well-behaved spectral properties of the manifold M .

Assume the hypotheses in Theorem 5 are satisfied. Fix $T > 0$. We want to show that there is a positive constant $A_T^* > 1$ (depending on r, ν, M, A_0 , and T , but

not on Z) such that

$$\|P_k \omega_Z(t)\|_2 \leq \frac{A_T^*}{|k|^r} \quad \forall t \in [0, T], \forall k \in Z. \quad (8)$$

By the enstrophy estimate, there is $\mathcal{E}_T^* > 1$, which may depend on ν , A_0 , M , and T , but does not depend on $Z \subset \mathbb{N}_0 + \lambda_1$, such that

$$\|\omega_Z(t)\|_{L^2}^2 + \|U_Z(t)\|_2^2 \leq \mathcal{E}_T^* \quad \text{for } t \in [0, T].$$

This means that for any $K_0 > \lambda_1$, setting

$$A_1 := (K_0^r + 1) \left(\frac{A_0}{\sqrt{\mathcal{E}_T^*}} + 1 \right) + \lambda_1,$$

we have

$$\|P_k \omega_Z(t)\|_2 < \frac{A_1 \sqrt{\mathcal{E}_T^*}}{|k|^r} \quad \text{for } t \in [0, T] \text{ and } k \in (\mathbb{N}_0 + \lambda_1) \cap [\lambda_1, K_0],$$

with $A_0 < A_1 \sqrt{\mathcal{E}_T^*}$. This estimate handles the contribution of low frequencies. We also have

$$P_k \omega_Z = 0 \quad \forall k \in (\mathbb{N}_0 + \lambda_1) \setminus Z.$$

Pick K_0 large (to be chosen later). We will show that $(\|P_k \omega_Z(t)\|_2)_{k \in \mathbb{N}_0 + \lambda_1}$ remains trapped in the set

$$\mathfrak{S}(K_0) = \left\{ (a_k)_{k \in \mathbb{N}_0 + \lambda_1} : a_k \leq \frac{A_1 \sqrt{\mathcal{E}_T^*}}{|k|^r} \quad \forall k \in \mathbb{N}_0 + \lambda_1 \right\}$$

Note that $(\|P_k \omega_Z(0)\|_2)_{k \in \mathbb{N}_0 + \lambda_1} \in \mathfrak{S}(K_0)$. The idea is that if

$$(\|P_k \omega_Z(t)\|_2)_{k \in \mathbb{N}_0 + \lambda_1}$$

were to exit the set $\mathfrak{S}(K_0)$ for some $t > 0$, it would have to go through

$$\mathfrak{S}_\partial(K_0) = \left\{ (a_k)_{k \in \mathbb{N}_0 + \lambda_1} : a_k \leq \frac{A_1 \sqrt{\mathcal{E}_T^*}}{|k|^r} \quad \forall k \in \mathbb{N}_0 + \lambda_1, \right. \\ \left. a_{\tilde{k}} = \frac{A_1 \sqrt{\mathcal{E}_T^*}}{|\tilde{k}|^r} \text{ for some } \tilde{k} \in (\mathbb{N}_0 + \lambda_1) \cap (K_0, \infty) \right\}$$

In other words, for some $k > K_0$, $\|P_k \omega_Z(t)\|_2$ must reach and then exceed $\frac{A_1 \sqrt{\mathcal{E}_T^*}}{|k|^r}$. If we can show that when $\|P_k \omega_Z(t)\|_2 = \frac{A_1 \sqrt{\mathcal{E}_T^*}}{|k|^r}$, we have

$$\partial_t \left(\|P_k \omega_Z(t)\|_2^2 \right) < 0,$$

then the evolution cannot exit the confining set $\mathfrak{S}(K_0)$.

To show this, we aim to show that the diffusion $\Delta P_k \omega_Z$ in (4) is the dominant term. Since

$$\|\Delta P_k \omega_Z(t)\|_2 \sim \frac{A_1 \sqrt{\mathcal{E}_T^*}}{|k|^{r-2}},$$

our goal is to show bounds which yield a stronger decay rate than $\frac{1}{|k|^{r-2}}$. In particular, we reduce the proof of Theorem 5 to the following lemma, which we will prove in Section 4.

Lemma 7 (Viscous domination). *Let r , A_0 and \mathcal{E}_T^* be as above. Let $K_0 \geq \lambda_1 + 10$ be arbitrary and set*

$$A_1 := (K_0^r + 1) \left(\frac{A_0}{\sqrt{\mathcal{E}_T^*}} + 1 \right) + \lambda_1(M).$$

Assume at time $t \in [0, T]$, we have $\|P_l \omega_Z(t)\|_2 \leq \frac{A_1 \sqrt{\mathcal{E}_T^*}}{|l|^r} \forall l \in \mathbb{N}_0 + \lambda_1$. Then for any $k \in (\mathbb{N}_0 + \lambda_1) \cap (K_0, \infty)$, we have

$$\begin{aligned} & \sum_{l_1, l_2 \in \mathbb{Z}} \left\| P_k \left\langle \text{curl}(-\Delta)^{-1} P_{l_1} \omega_Z(t), \nabla P_{l_2} \omega_Z(t) \right\rangle \right\|_2 \\ & \quad + \sum_{l \in \mathbb{Z}} \|P_k \langle \mathcal{P}_{\mathcal{H}} U_Z(t), \nabla P_l \omega_Z(t) \rangle\|_2 \\ & \quad + \sum_{l \in \mathbb{Z}} \nu \left\| P_k D^2 (-\Delta)^{-1} P_l \omega_Z(t) \right\|_2 \\ & \quad + \nu \|P_k D^1 \mathcal{P}_{\mathcal{H}} U_Z(t)\|_2 \lesssim_{\nu, M, r, -Z, -T, -K_0} \frac{A_1 \mathcal{E}_T^*}{|k|^{r-\frac{7}{4}}}. \end{aligned}$$

To conclude this section, we give the proof of Theorem 5 under the assumption that we have already shown Lemma 7.

Proof of Theorem 5. Fit $T > 0$, choose K_0 large, and let A_1 be as defined above. Then if $0 < t < T$ is such that

$$\|P_k \omega_Z(t)\|_2 = \frac{A_1 \sqrt{\mathcal{E}_T^*}}{|k|^r}$$

and

$$\|P_l \omega_Z(t)\|_2 \leq \frac{A_1 \sqrt{\mathcal{E}_T^*}}{|l|^r} \quad \text{for all } l \in \mathbb{N}_0 + \lambda_1,$$

it follows that we have

$$\begin{aligned} \partial_t \left(\frac{\|P_k \omega_Z(t)\|_2^2}{2} \right) &= O_{\nu, M, r, -Z, -T, -K_0} \left(\frac{A_1 \mathcal{E}_T^*}{|k|^{r-\frac{7}{4}}} \|P_k \omega_Z(t)\|_2 \right) \\ & \quad + \nu \langle \langle \Delta P_k \omega_Z(t), P_k \omega_Z(t) \rangle \rangle. \end{aligned}$$

Observe that $\langle \langle \Delta P_k \omega_Z(t), P_k \omega_Z(t) \rangle \rangle < 0$ and

$$|\langle \langle \Delta P_k \omega_Z(t), P_k \omega_Z(t) \rangle \rangle| \sim_{M, -Z, -T, -K_0} \frac{A_1 \sqrt{\mathcal{E}_T^*}}{|k|^{r-2}} \|P_k \omega_Z(t)\|_2.$$

In particular, we can choose K_0 so that $\frac{\sqrt{\mathcal{E}_T^*}}{K_0^{1/4}} \ll_{\nu, M, r, -Z, -T, -K_0} 1$, thereby obtaining

$$\partial_t \left(\frac{\|P_k \omega_Z(t)\|_2^2}{2} \right) < 0.$$

Then $(\|P_k \omega_Z(t)\|_2) \in \mathfrak{S}(K_0)$ for all $t \in [0, T]$, and the desired bound (8) follows by setting $A_T^* = A_1 \sqrt{\mathcal{E}_T^*}$. \square

4. VISCOUS DOMINATION

In this section, we prove Lemma 7. To frame our techniques, we recall a classical result used in the study of the nonlinear Schrödinger equation.

Proposition 8. *For any $f, g \in L^2(M)$ and $l_1, l_2 \geq \lambda_1(M)$ and $a, b \in \mathbb{N}_0$, we have*

$$\|(\nabla^a P_{l_1} f) * (\nabla^b P_{l_2} f)\|_2 \lesssim_M \min(l_1, l_2)^{\frac{1}{4}} l_1^a \|P_{l_1} f\|_2 l_2^b \|P_{l_2} f\|_2$$

where $(\nabla^a P_{l_1} f) * (\nabla^b P_{l_2} f)$ is schematic for any contraction of the two tensors.

Proof. Let $\chi \in \mathcal{S}(\mathbb{R})$ such that $\chi = 1$ on $[0, 1]$. Define $\chi_\lambda = \chi(\sqrt{-\Delta} - \lambda)$. Then $\chi_{l_1} P_{l_1} f = P_{l_1} f$, and we can use [9, Equation 7.13].¹ \square

We will make use of a variant of this result, adapted to the frequency cutoff operators defined in Section 2.2.

Since we want to avoid relying on facts about the distribution of eigenvalues, we will use a Fourier decomposition technique, decomposing the multilinear symbols into linear pieces (see, e.g. [4, Lemma 2.10] or [9, Proposition 7.5]). This strategy, which we will refer to in the rest of this paper as the ‘‘Fourier trick,’’ allows us to pass between frequency cutoffs P_k and eigenspace projections π_s .

Lemma 9 (Bilinear estimate). *For any $f, g \in L^2(M)$ and $l_1, l_2 \geq \lambda_1(M)$ and $a, b, c \in \mathbb{N}_0$, we have*

$$\|(\nabla^a P_{l_1} f) * (\nabla^b (-\Delta)^{-c} P_{l_2} g)\|_2 \lesssim_M \min(l_1, l_2)^{\frac{1}{4}} l_1^a \|P_{l_1} f\|_2 l_2^{b-2c} \|P_{l_2} g\|_2$$

where $(\nabla^a P_{l_1} f) * (\nabla^b P_{l_2} g)$ is schematic for any contraction of the two tensors.

The main intuition underlying the connection between Proposition 8 and Lemma 9 is that $(-\Delta)^{-c} P_{l_2}$ is almost like $l_2^{-2c} P_{l_2}$ (but not quite, as frequency cutoffs are a bit different from eigenspace projections).

Proof of Lemma 9. Let $h \in L^2(M)$ such that $\|h\|_2 \leq 1$. We want to show

$$\begin{aligned} & \left\langle \left\langle (\nabla^a P_{l_1} f) * (\nabla^b (-\Delta)^{-c} P_{l_2} g), h \right\rangle \right\rangle \\ &= O\left(\min(l_1, l_2)^{\frac{1}{4}} l_1^a \|P_{l_1} f\|_2 l_2^{b-2c} \|P_{l_2} g\|_2\right). \end{aligned} \quad (9)$$

Observe that, using eigenspace projections, the left-hand side of (9) can be rewritten as

$$\sum_{\substack{z_j \in (0,1) \cap (\sigma(\sqrt{-\Delta}) - l_j) \\ j=1,2}} \frac{1}{(l_2 + z_2)^{2c}} \left\langle \left\langle (\nabla^a \pi_{l_1+z_1} f) * (\nabla^b \pi_{l_2+z_2} g), h \right\rangle \right\rangle$$

¹The statement in [9] contains a slight typo [10]. The correct factor $\min(l_1, l_2)^{\frac{1}{4}}$ was originally given in [2].

Set $\psi(z_1, z_2) = \frac{1}{(l_2 + z_2)^{2c}}$ for $z_1, z_2 \in [0, 1]$. Simple calculations show that

$$\|\psi\|_{C^2([0,1]^2)} \lesssim_{\lambda_1} \frac{1}{l_2^{2c}}.$$

We can easily extend ψ to a C^2 function ψ_1 supported in $(-2, 2)^2$ such that $\|\psi_1\|_{C^2} \lesssim \|\psi\|_{C^2}$. Then we can treat ψ_1 as a C^2 periodic function on $[-2, 2]^2$ and apply Fourier inversion: $\psi_1(z_1, z_2) = \sum_{\theta_1, \theta_2 \in \frac{\mathbb{Z}}{4}} \widehat{\psi}_1(\theta_1, \theta_2) e^{i2\pi z \cdot \theta}$ with

$$\left\| \widehat{\psi}_1 \right\|_{l^1} \lesssim \left\| \langle \theta \rangle^2 \widehat{\psi}_1(\theta) \right\|_{l^2_\theta \left(\frac{\mathbb{Z}^2}{4} \right)} \left\| \frac{1}{\langle \theta \rangle^2} \right\|_{l^2_\theta \left(\frac{\mathbb{Z}^2}{4} \right)} \lesssim \|\psi_1\|_{H^2} \lesssim \|\psi\|_{C^2} \lesssim \frac{1}{l_2^{2c}}.$$

We can then rewrite the left-hand side of (9) as

$$\begin{aligned} & \sum_{z_1, z_2} \sum_{\theta_1, \theta_2 \in \frac{\mathbb{Z}}{4}} \widehat{\psi}_1(\theta_1, \theta_2) \langle \langle (\nabla^a \pi_{l_1 + z_1} f e^{i2\pi z_1 \theta_1}) * (\nabla^b \pi_{l_2 + z_2} g e^{i2\pi z_2 \theta_2}), h \rangle \rangle \\ &= \sum_{\theta_1, \theta_2 \in \frac{\mathbb{Z}}{4}} \widehat{\psi}_1(\theta_1, \theta_2) \langle \langle (\nabla^a P_{l_1} f_{\theta_1}) * (\nabla^b P_{l_2} g_{\theta_2}), h \rangle \rangle, \end{aligned}$$

where the outer sum on the left hand side is over the index set

$$\{(z_1, z_2) : z_j \in [0, 1] \cap (\sigma(\sqrt{-\Delta}) - l_j) \text{ for } j = 1, 2\},$$

and where we've set

$$f_{\theta_1} := \sum_{z_1 \in [0, 1] \cap (\sigma(\sqrt{-\Delta}) - l_1)} \pi_{l_1 + z_1} f e^{i2\pi z_1 \theta_1}$$

and

$$g_{\theta_2} := \sum_{z_2 \in [0, 1] \cap (\sigma(\sqrt{-\Delta}) - l_2)} \pi_{l_2 + z_2} g e^{i2\pi z_2 \theta_2}.$$

The crucial point is that the L^2 norm is modulation-independent, and the eigenspaces are mutually orthogonal, so $\|P_{l_1} f_{\theta_1}\|_2 = \|P_{l_1} f\|_2$, $\|P_{l_2} g_{\theta_2}\|_2 = \|P_{l_2} g\|_2$.

Applying Proposition 8 and noting that

$$\begin{aligned} & \sum_{\theta_1, \theta_2 \in \frac{\mathbb{Z}}{4}} \widehat{\psi}_1(\theta_1, \theta_2) O_{-\theta_1, -\theta_2} \left(\min(l_1, l_2)^{\frac{1}{4}} l_1^a \|P_{l_1} f\|_2 l_2^b \|P_{l_2} g\|_2 \right) \\ &= O \left(\left\| \widehat{\psi}_1 \right\|_{l^1} \min(l_1, l_2)^{\frac{1}{4}} l_1^a \|P_{l_1} f\|_2 l_2^b \|P_{l_2} g\|_2 \right), \end{aligned}$$

the desired conclusion follows. \square

While the estimate established in Lemma 9 is good enough for the so-called ‘‘triangle regions’’ in our analysis (see Claim A in Section 4), we will also need another estimate to treat the ‘‘distant regions’’ of frequency interactions. In [9], Hani showed that for any $f, g, h \in L^2(M)$ and $l_1 \geq l_2 \geq l_3 \geq \lambda_1(M)$ such that $l_1 = l_2 + Kl_3 + 2$ for $K > 1$, one has

$$\left| \int_M (P_{l_1} f) (P_{l_2} g) (P_{l_3} h) \right| \lesssim_{J, M} \frac{l_3^{\frac{1}{4}}}{K^J} \|P_{l_1} f\|_2 \|P_{l_2} g\|_2 \|P_{l_3} h\|_2$$

for all $J \in \mathbb{N}_0$.

We generalize this result to the following lemma.

Lemma 10 (Trilinear estimate). *For any $f_1, f_2, f_3 \in L^2(M)$; $a_1, b_1, a_2, b_2, a_3, b_3, J \in \mathbb{N}_0$ and $l_1 \geq l_2 \geq l_3 \geq \lambda_1(M)$ such that $l_1 = l_2 + Kl_3 + 2$ for $K > 1$, we have*

$$\left| \int_M \left(\nabla^{a_1} (-\Delta)^{-b_1} P_{l_1} f_1 \right) * \left(\nabla^{a_2} (-\Delta)^{-b_2} P_{l_2} f_2 \right) * \left(\nabla^{a_3} (-\Delta)^{-b_3} P_{l_3} f_3 \right) \right| \\ \lesssim_{J, M, -l_1, -l_2, -l_3} \frac{l_3^{\frac{1}{4}}}{K^J} \prod_{j=1}^3 l_j^{a_j - 2b_j} \|P_{l_j} f_j\|_2$$

The proof of Lemma 10 is given in Appendix B. The ideas involved are similar to the tools used in the proof of Lemma 9 above.

We now proceed to the proof of Lemma 7. To make the argument easier to follow, we note that it suffices to establish the following self-contained statement. This formulation makes it clear that there is no dependence on K_0, T, Z in Lemma 7.

Lemma 7' (Viscous domination, restated). *Let $w \in C^\infty(M)$ and $u \in \mathcal{P}_{\mathcal{H}}\mathfrak{X}(M)$. Let $A, B \geq 1$ and $k \in \mathbb{N}_0 + \lambda_1 + 10$. Let $r > 1$. Assume that $\pi_0 w = 0$ and $\|P_l w\|_2 \leq \frac{A}{|l|^r}$ for all $l \in \mathbb{N}_0 + \lambda_1$. Assume also that $\|w\|_2 + \|u\|_2 = \left\| \|P_j w\|_2 \right\|_{l_j^2(\mathbb{N}_0 + \lambda_1)} + \|u\|_2 \leq B$.*

Then

$$\sum_{l_1, l_2 \in \mathbb{N}_0 + \lambda_1} \left\| P_k \left\langle \text{curl}(-\Delta)^{-1} P_{l_1} w, \nabla P_{l_2} w \right\rangle \right\|_2 + \sum_{l \in \mathbb{N}_0 + \lambda_1} \|P_k \langle \mathcal{P}_{\mathcal{H}} u, \nabla P_l w \rangle\|_2 \\ + \sum_{l \in \mathbb{N}_0 + \lambda_1} \left\| P_k D^2 \text{curl}(-\Delta)^{-1} P_l w \right\|_2 + \|P_k D^1 \mathcal{P}_{\mathcal{H}} u\|_2 \lesssim_{M, r} \frac{AB}{|k|^{r - \frac{7}{4}}}$$

We will split this problem into smaller claims, handling the contribution of each term. This is the content of the next three subsections, the combination of which together establish Lemma 7'.

4.1. The convective term. The main tools we will use are Lemma 9 and Lemma 10. We also note that for $p \in [1, \infty]$ and $\alpha \in \mathbb{R}$:

- $\|l^\alpha\|_{l_{1 \leq l \leq k}^p} \lesssim k^{\alpha + \frac{1}{p}}$ for $\alpha p > -1$.
- $\|\frac{1}{l^\alpha}\|_{l_{l \geq k}^p} \sim \frac{1}{k^{\alpha - \frac{1}{p}}}$ for $\alpha p > 1$.

Claim A. Firstly, we will show

$$\sum_{\substack{l_1, l_2 \in \mathbb{N}_0 + \lambda_1 \\ |l_1 - l_2| \leq k \leq l_1 + l_2}} \left\| P_k \left\langle \text{curl}(-\Delta)^{-1} P_{l_1} w, \nabla P_{l_2} w \right\rangle \right\|_2 \lesssim \frac{AB}{k^{r - \frac{7}{4}}}$$

Remark. These ‘‘triangle regions’’ are all we need to complete the proof of Lemma 7' (and its original formulation Lemma 7), and thus also of Theorem 1, in the case when M is the sphere $S^2 \subset \mathbb{R}^3$. Indeed, on the sphere, we have $\text{Ric}(X) = X$ and $\mathcal{P}_{\mathcal{H}} = 0$. In this case, we are therefore justified in setting $\Delta_M = \Delta_H + c$ where $c \in \mathbb{R}$ is a constant, which is easy to handle as $c \|P_k \omega_Z\|_2 \lesssim_{\lambda_1} \|\Delta P_k \omega_Z\|_2$. Also,

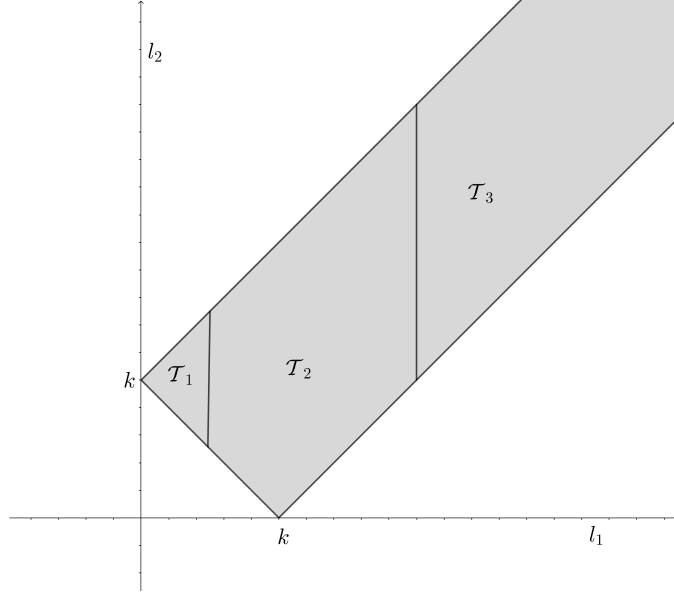

FIGURE 1. The triangle regions.

we have $P_k \langle \text{curl}(-\Delta)^{-1} P_{l_1} \omega_Z(t), \nabla P_{l_2} \omega_Z(t) \rangle = 0$ if (k, l_1, l_2) does not obey the triangle inequalities; see [5, Equation (26)].

Proof of Claim A. Let $\mathcal{T} = \{(l_1, l_2) : l_1, l_2 \in \mathbb{N}_0 + \lambda_1 \text{ and } |l_1 - l_2| \leq k \leq l_1 + l_2\}$. We write $\mathcal{T} = \mathcal{T}_1 \cup \mathcal{T}_2 \cup \mathcal{T}_3$, where the sets \mathcal{T}_i are defined by

$$\mathcal{T}_1 = \{(l_1, l_2) \in \mathcal{T} : l_1 \leq \frac{k}{2}\},$$

$$\mathcal{T}_2 = \{(l_1, l_2) \in \mathcal{T} : \frac{k}{2} < l_1 \leq 2k\},$$

and

$$\mathcal{T}_3 = \{(l_1, l_2) \in \mathcal{T} : l_1 > 2k\}.$$

We begin by estimating the contribution of \mathcal{T}_1 . In this case, we have $l_1 \leq l_2 \sim k$, and the contribution of terms from \mathcal{T}_1 is bounded by

$$\sum_{l_1} \sum_{l_2} l_1^{1/4} \frac{1}{l_1} \|P_{l_1} w\|_2 k \|P_{l_2} w\|_2 \lesssim \sum_{l_1} l_1^{1/4} \|P_{l_1} w\|_2 k \frac{A}{k^r} \quad (10)$$

where to obtain the last inequality we have noted that for each l_1 , there are at most $2l_1$ choices of l_2 . The Hölder inequality now gives the bound

$$(10) \lesssim k^{3/4} B \cdot k \frac{A}{k^r} = \frac{AB}{k^{r-7/4}}$$

We now estimate the contribution from \mathcal{T}_2 . Here we have $l_2 \lesssim k \sim l_1$. The contribution is then bounded by

$$\sum_{l_1} \sum_{l_2} k^{1/4} \frac{1}{k} \|P_{l_1} w\|_2 l_2 \|P_{l_2} w\|_2 \lesssim \sum_{l_1} k^{1/4} \frac{1}{k} \|P_{l_1} w\|_2 k^{\frac{3}{2}} B$$

$$\leq \sum_{l_1} \frac{AB}{k^{r-3/4}} \quad (11)$$

where the Hölder inequality is used in passing from left to right in the first line. Recalling that there are at most $O(k)$ choices for the value of l_1 in the summation for this contribution, we obtain the bound

$$(11) \lesssim \frac{AB}{k^{r-7/4}}.$$

It remains to estimate the \mathcal{T}_3 contribution. For this, we have $k \lesssim l_1 \sim l_2$, and we note that, for each fixed l_1 , the number of choices for l_2 is at most $O(k)$. Making the change of variable $l_2 = l_1 + j$, where $|j| \leq k$, the contribution of \mathcal{T}_3 is bounded by

$$\begin{aligned} \sum_j \sum_{l_1} l_1^{1/4} \frac{1}{l_1} \|P_{l_1} w\|_2 (l_1 + j) \|P_{l_1+j} w\|_2 &\lesssim \sum_j \sum_{l_1} \frac{A}{l_1^{r-1/4}} \|P_{l_1+j} w\|_2 \\ &\lesssim \sum_j \frac{A}{k^{r-3/4}} B \\ &\lesssim \frac{AB}{k^{r-7/4}}, \end{aligned}$$

where we used the Hölder inequality to pass from the first to second lines. Note that in this calculation we needed $2(r - \frac{1}{4}) > 1$. \square

As we observed above, this completes the proof in the case of the sphere $M = S^2$. To treat more general manifolds, we will invoke the trilinear estimate in Lemma 10 to estimate the contribution of the “distant regions” (where $\max(k, l_1, l_2)$ is far bigger than the rest). In addition, between the triangle regions and the distant regions, there are “intermediate regions” where we require more ad-hoc arguments.

Claim B. With $k \in \mathbb{N}_0 + \lambda_1 + 10$, set

$$\mathcal{A} := \{(l_1, l_2) : l_1, l_2 \in \mathbb{N}_0 + \lambda_1 \text{ and } |l_1 - l_2| > k\},$$

and

$$\mathcal{B} = \{(l_1, l_2) : l_1, l_2 \in \mathbb{N}_0 + \lambda_1 \text{ and } l_1 + l_2 < k\}.$$

Then

$$\sum_{(l_1, l_2) \in \mathcal{A} \cup \mathcal{B}} \left\| P_k \left\langle \text{curl}(-\Delta)^{-1} P_{l_1} w, \nabla P_{l_2} w \right\rangle \right\|_2 \lesssim_M \frac{AB}{k^{r-\frac{7}{4}}}$$

Proof. In using Lemma 10, we will set J as large as necessary.

We split $\mathcal{A} = \{|l_1 - l_2| > k\}$ into smaller regions

$$\mathcal{A}_1 := \{l_1 \leq k\} \cap \mathcal{A},$$

$$\mathcal{A}_2 := \{l_1 \geq k, l_2 \geq k\} \cap \mathcal{A},$$

and

$$\mathcal{A}_3 := \{l_1 \geq k > l_2\} \cap \mathcal{A}.$$

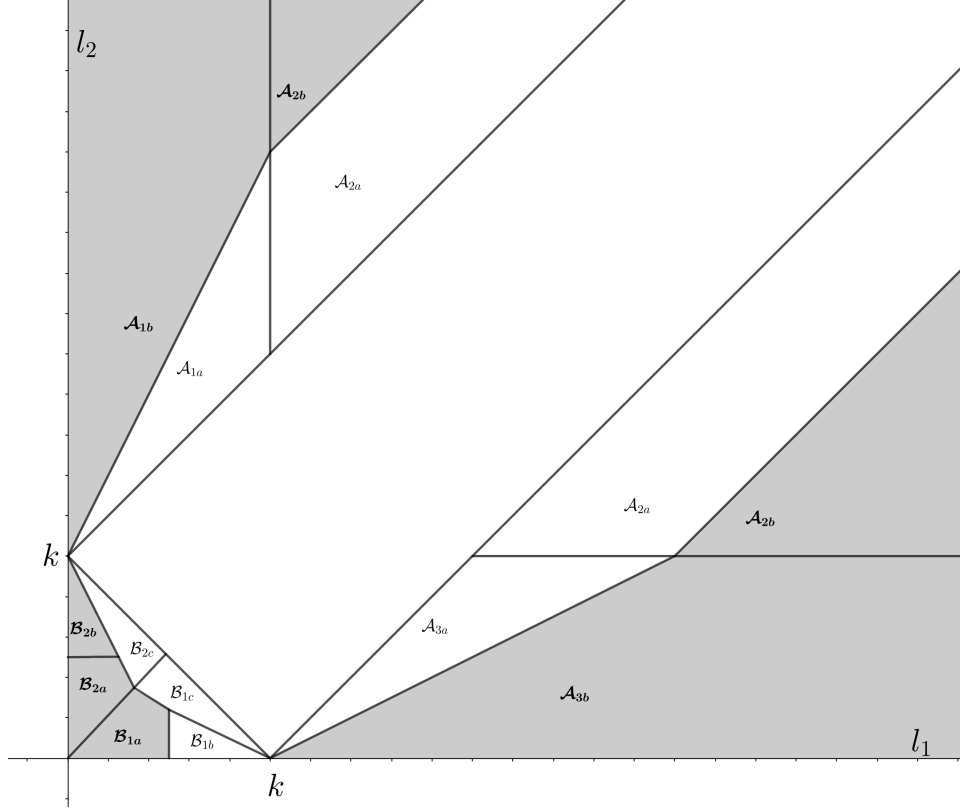

FIGURE 2. The non-triangle regions. Shaded regions indicate where the trilinear estimate of Lemma 10 is used.

We begin by estimating the contribution of \mathcal{A}_1 . For this, we consider the contribution

$$\mathcal{A}_{1a} = \{l_1 \leq k \leq l_2 \leq k + 2l_1 + 2\} \cap \mathcal{A},$$

for which $l_1 \leq l_2 \sim k$, and for each fixed l_1 , there are at most $O(l_1)$ choices for the index l_2 . The contribution is then bounded by

$$\begin{aligned} & \sum_{l_1} \sum_{l_2} l_1^{1/4} \frac{1}{l_1} \|P_{l_1} w\|_2 k \|P_{l_2} w\|_2 \\ & \lesssim \sum_{l_1} l_1^{1/4} \|P_{l_1} w\|_2 k \frac{A}{k^r} \\ & \lesssim k^{3/4} B \cdot \frac{A}{k^{r-1}}. \end{aligned}$$

To handle the contribution

$$\mathcal{A}_{1b} = \{l_1 \leq k < k + 2l_1 + 2 < l_2\} \cap \mathcal{A},$$

where $k + 2l_1 + 2 \sim k$, we invoke Lemma 10, to bound the contribution by

$$\begin{aligned} & \sum_{l_1} \sum_{l_2} l_1^{1/4} \frac{l_1^J}{(l_2 - k - 2)^J} \frac{1}{l_1} \|P_{l_1} w\|_2 l_2 \|P_{l_2} w\|_2 \\ & \leq \sum_{l_1} l_1^{J-3/4} \|P_{l_1} w\|_2 \sum_{l_2} \frac{A}{l_2^{r-1} (l_2 - k - 2)^J} \end{aligned} \quad (12)$$

Now, choose $p \in (1, \infty)$ and $J \in \mathbb{N}_0$ such that $(r-1)p > 1$, $Jp' > 1$, and

$$2 \left(\frac{1}{p'} - \frac{3}{4} \right) = 2 \left(\frac{1}{4} - \frac{1}{p} \right) > -1.$$

The condition $r > 1$ ensures that this choice is possible. Using the Hölder inequality in the summation over l_2 to bound by the $\ell_{l_2}^p$ and $\ell_{l_2}^{p'}$ norms, we then have

$$\begin{aligned} (12) & \lesssim \sum_{l_1} l_1^{J-3/4} \|P_{l_1} w\|_2 A \frac{1}{k^{r-1-\frac{1}{p}} l_1^{J-\frac{1}{p'}}} \\ & = \frac{A}{k^{r-1-\frac{1}{p}}} \sum_{l_1} l_1^{\frac{1}{p'} - \frac{3}{4}} \|P_{l_1} w\|_2 \\ & \lesssim \frac{A}{k^{r-1-1/p}} B k^{\frac{1}{p'} - \frac{1}{4}}, \end{aligned}$$

where we have used the Hölder inequality again to obtain the last inequality. This completes the estimate of the \mathcal{A}_1 contribution.

To estimate the contribution of \mathcal{A}_2 , we again subdivide into further cases. We first consider the contribution from

$$\mathcal{A}_{2a} = \{k < |l_1 - l_2| < 2k + 2\} \cap \mathcal{A}_2.$$

Here, we have $k \lesssim l_1 \sim l_2$, and we invoke the change of variable $l_2 = l_1 + j$, where $|j| \lesssim k$. The contribution is bounded by

$$\begin{aligned} \sum_j \sum_{l_1} l_1^{1/4} \|P_{l_1} w\|_2 \|P_{l_1+j} w\|_2 & \leq \sum_j \sum_{l_1} \frac{A}{l_1^{r-1/4}} \|P_{l_1+j} w\|_2 \\ & \lesssim \sum_j \frac{A}{k^{r-3/4}} B \lesssim \frac{AB}{k^{r-7/4}}, \end{aligned}$$

where the last line follows from the Hölder inequality, and where we have used $2(r-1/4) > 1$.

The remaining contribution from \mathcal{A}_2 is the contribution of

$$\mathcal{A}_{2b} = \{2k + 2 \leq |l_1 - l_2|\} \cap \mathcal{A}_2.$$

Here, we have $k \geq 1 + \lambda_1$, and thus $||l_1 - l_2| - 2| \sim |l_1 - l_2|$. Using Lemma 10, the contribution is bounded by

$$\begin{aligned} & \sum_{l_1} \sum_{l_2} l_1^{1/4} \frac{k^J}{|l_2 - l_1|^J} \frac{1}{l_1} \|P_{l_1} w\|_2 l_2 \|P_{l_2} w\|_2 \\ & \leq A k^J \sum_{l_1} \frac{1}{l_1^{3/4}} \|P_{l_1} w\|_2 \sum_{l_2} \frac{1}{|l_2 - l_1|^J} \cdot \frac{1}{l_2^{r-1}} \end{aligned} \quad (13)$$

Choosing J and p such that $Jp > 1, (r-1)p' > 1$ (this is possible, since $r > 1$), and using the Hölder inequality to estimate the summation in l_2 by appropriate $\ell_{l_2}^p$ and $\ell_{l_2}^{p'}$ norms, we obtain

$$\begin{aligned}
(13) &\lesssim Ak^J \sum_{l_1} \frac{1}{l_1^{3/4}} \|P_{l_1} w\|_2 \frac{1}{k^{J-1/p}} \cdot \frac{1}{k^{r-1-1/p'}} \\
&= A \frac{1}{k^{r-2}} \sum_{l_1} \frac{1}{l_1^{3/4}} \|P_{l_1} w\|_2 \\
&\lesssim A \frac{1}{k^{r-2}} \frac{1}{k^{1/4}} B,
\end{aligned}$$

where the last line follows from another application of the Hölder inequality.

We now address the contribution of \mathcal{A}_3 . This further splits into:

$$\mathcal{A}_{3a} = \{k + 2l_2 + 2 > l_1 \geq k > l_2\} \cap \mathcal{A}_3 \quad (14)$$

and

$$\mathcal{A}_{3b} = \{l_1 \geq k + 2l_2 + 2 \geq k > l_2\} \cap \mathcal{A}_3. \quad (15)$$

To handle the contribution of (14), note that in this case $l_2 < k \sim l_1$, and that for each l_2 , the number of choices of l_1 contributing to the sum is $O(l_2)$. The contribution is thus bounded by

$$\begin{aligned}
&\sum_{l_2} \sum_{l_1} l_2^{1/4} \frac{1}{k} \|P_{l_1} w\|_2 l_2 \|P_{l_2} w\|_2 \\
&\lesssim \sum_{l_2} \sum_{l_1} \frac{A}{k^{r+1}} l_2^{5/4} \|P_{l_2} w\|_2 \\
&\lesssim \frac{A}{k^{r+1}} \sum_{l_2} l_2^{9/4} \|P_{l_2} w\|_2 \\
&\lesssim \frac{A}{k^{r+1}} k^{11/4} B = \frac{AB}{k^{r-7/4}},
\end{aligned}$$

where, in passing from the second to third lines, we've used the bound on the number of terms in the summation over l_1 , and in passing to the last line, we've used the Hölder inequality.

We now turn to the contribution of (15). Here $k + 2l_2 + 2 \sim k$. Using Lemma 10, this contribution is bounded by

$$\begin{aligned}
&\sum_{l_2} \sum_{l_1} l_2^{1/4} \frac{l_2^J}{(l_1 - k - 2)^J} \frac{1}{l_1} \|P_{l_1} w\|_2 l_2 \|P_{l_2} w\|_2 \\
&\lesssim \sum_{l_2} \sum_{l_1} \frac{l_2^{J+5/4}}{(l_1 - k - 2)^J} \frac{A}{l_1^{r+1}} \|P_{l_2} w\|_2 \\
&\lesssim \sum_{l_2} \frac{l_2^{J+5/4}}{l_2^{J-1/2}} \frac{A}{k^{r+1/2}} \|P_{l_2} w\|_2 \\
&\lesssim k^{9/4} \frac{A}{k^{r+1/2}} B = \frac{AB}{k^{r-7/4}},
\end{aligned}$$

where we have used the Hölder inequality in the last two lines.

We similarly divide $\mathcal{B} = \{l_1 + l_2 < k\}$ into smaller regions. The first of these is $\mathcal{B}_1 = \{l_1 \geq l_2\}$, which we subdivide into two further sets of indices. The first contribution is that of

$$\mathcal{B}_{1a} = \{k \geq l_1 + 2l_2 + 2; l_1 \leq \frac{k}{2}\} \cap \mathcal{B}_1.$$

Here, because $k \geq 10$, we have $k - l_1 - 2 \sim k$, and the contribution is bounded by

$$\begin{aligned} & \sum_{l_2} \sum_{l_1} l_2^{1/4} \frac{l_2^J}{k^J} \frac{1}{l_1} \|P_{l_1} w\|_2 l_2 \|P_{l_2} w\|_2 \\ & \leq \frac{1}{k^J} \sum_{l_1} \sum_{l_2} l_2^{J+\frac{5}{4}} \frac{1}{l_1^{r+1}} A \|P_{l_2} w\|_2 \\ & \lesssim \frac{1}{k^J} \sum_{l_1} l_1^{J+\frac{7}{4}} \frac{1}{l_1^{r+1}} AB \\ & \lesssim \frac{1}{k^J} k^{J+\frac{7}{4}-r} AB = \frac{AB}{k^{r-7/4}}, \end{aligned}$$

where we have again used the Hölder inequality to pass from the second to third lines, and where we have used $J + \frac{7}{4} - r - 1 > -1$ (which holds trivially).

The two remaining subdivisions of the index set $\{l_1 \geq l_2\}$ are

$$\mathcal{B}_{1b} = \{k \geq l_1 + 2l_2 + 2; l_1 > \frac{k}{2}\} \cap \mathcal{B}_1 \quad \text{and} \quad \mathcal{B}_{1c} = \{l_1 + 2l_2 + 2 > k\} \cap \mathcal{B}_1.$$

In both cases, $l_1 \sim k$, and the contribution is bounded by

$$\begin{aligned} & \sum_{l_2} \sum_{l_1} l_2^{1/4} \frac{1}{k} \|P_{l_1} w\|_2 l_2 \|P_{l_2} w\|_2 \\ & \lesssim \frac{A}{k^{r+1}} \sum_{l_2} \sum_{l_1} l_2^{5/4} \|P_{l_2} w\|_2 \\ & \lesssim \frac{A}{k^r} \sum_{l_2} l_2^{5/4} \|P_{l_2} w\|_2 \\ & \lesssim \frac{A}{k^r} k^{7/4} B = \frac{AB}{k^{r-7/4}} \end{aligned}$$

where in passing from the second to third lines we have used that for each l_2 there are at most $O(k)$ choices of index l_1 contributing to the summation, and in passing to the last line, we've use the Hölder inequality.

The second region contributing to \mathcal{B} is $\mathcal{B}_2 = \{l_1 < l_2\}$. This again further splits into several parts. The first such contribution is that of

$$\mathcal{B}_{2a} = \{k \geq 2l_1 + l_2 + 2; l_2 \leq \frac{k}{2}\} \cap \mathcal{B}_2.$$

Here, because $k \geq 10$, we have $k - l_2 - 2 \sim k$, and the contribution is bounded by

$$\sum_{l_2} \sum_{l_1} l_1^{1/4} \frac{l_1^J}{k^J} \frac{1}{l_1} \|P_{l_1} w\|_2 l_2 \|P_{l_2} w\|_2$$

$$\begin{aligned}
&\leq \frac{1}{k^J} \sum_{l_2} \sum_{l_1} l_1^{J-\frac{3}{4}} \|P_{l_1} w\|_2 \frac{1}{l_2^{r-1}} A \\
&\lesssim \frac{1}{k^J} \sum_{l_2} l_2^{J-\frac{1}{4}} B \frac{1}{l_2^{r-1}} A \\
&\lesssim \frac{1}{k^J} k^{J+3/4-r+1} B A = \frac{AB}{k^{r-7/4}}
\end{aligned}$$

where in passing from the second to third lines we have used the Hölder inequality, and where we have used $J + \frac{3}{4} - r > -1$ and $2(J - 3/4) > -1$ (which hold trivially) to bound the sums.

The next contribution comes from

$$\mathcal{B}_{2b} = \{k \geq 2l_1 + l_2 + 2; l_2 > \frac{k}{2}\} \cap \mathcal{B}_2.$$

For these terms, we have $l_2 \sim k$, and the contribution is bounded by

$$\begin{aligned}
&\sum_{l_2} \sum_{l_1} l_1^{1/4} \frac{l_1^J}{(k - l_2 - 2)^J} \frac{1}{l_1} \|P_{l_1} w\|_2 k \|P_{l_2} w\|_2 \\
&\lesssim \frac{A}{k^{r-1}} \sum_{l_1} \sum_{l_2} \frac{l_1^{J-3/4}}{(k - l_2 - 2)^J} \|P_{l_1} w\|_2 \\
&\lesssim \frac{A}{k^{r-1}} \sum_{l_1} \frac{l_1^{J-3/4}}{l_1^{J-1}} \|P_{l_1} w\|_2 \\
&\lesssim \frac{A}{k^{r-1}} k^{3/4} B = \frac{AB}{k^{r-7/4}},
\end{aligned}$$

where we've again used the Hölder inequality in passing to the last line.

It remains to estimate the contribution from

$$\mathcal{B}_{2c} = \{2l_1 + l_2 + 2 > k\} \cap \mathcal{B}_2.$$

Here, $l_2 \sim k$.

$$\begin{aligned}
&\sum_{l_2} \sum_{l_1} l_1^{1/4} \frac{1}{l_1} \|P_{l_1} w\|_2 k \|P_{l_2} w\|_2 \\
&\lesssim \frac{A}{k^{r-1}} \sum_{l_1} \sum_{l_2} \frac{1}{l_1^{3/4}} \|P_{l_1} w\|_2 \\
&\lesssim \frac{A}{k^{r-1}} \sum_{l_1} l_1^{1/4} \|P_{l_1} w\|_2 \\
&\lesssim \frac{A}{k^{r-1}} k^{3/4} B = \frac{AB}{k^{r-7/4}}
\end{aligned}$$

where in passing from the second line to the third line we have observed that, since $l_2 < k - l_1$, for each fixed l_1 there are at most $O(l_1)$ choices for the index l_2 , and in passing to the last line, we've used the Hölder inequality.

The proof of the claim is now complete. \square

4.2. **The harmonic term.** We note that for all $m \in \mathbb{N}_0$,

$$\|D^1 \mathcal{P}_{\mathcal{H}} u\|_{H^{2m}} \lesssim \|\mathcal{P}_{\mathcal{H}} u\|_{H^{2m+1}} \lesssim_m \|\mathcal{P}_{\mathcal{H}} u\|_2 \lesssim B.$$

We also observe that

$$\begin{aligned} \|D^1 \mathcal{P}_{\mathcal{H}} u\|_{H^{2m}} &\sim_M \|\pi_0 D^1 \mathcal{P}_{\mathcal{H}} u\|_2 + \|(1 - \pi_0) D^1 \mathcal{P}_{\mathcal{H}} u\|_{H^{2m}} \\ &\sim \|\pi_0 D^1 \mathcal{P}_{\mathcal{H}} u\|_2 + \|\Delta^m D^1 \mathcal{P}_{\mathcal{H}} u\|_2 \\ &\sim \|\pi_0 D^1 \mathcal{P}_{\mathcal{H}} u\|_2 + \left\| \left\| P_k k^{2m} D^1 \mathcal{P}_{\mathcal{H}} u \right\|_2 \right\|_{l_k^2(\mathbb{N}_0 + \lambda_1)}. \end{aligned}$$

As a consequence, for all $k \in \mathbb{N}_0 + \lambda_1$ and $m \in \mathbb{N}_0$, we have

$$\|P_k D^1 \mathcal{P}_{\mathcal{H}} u\| \lesssim_{M,m} \frac{B}{k^{2m}}.$$

Choosing $m = m(r)$ large enough then leads to

$$\|P_k D^1 \mathcal{P}_{\mathcal{H}} u\|_2 \lesssim_{M,r} \frac{AB}{k^{r-7/4}}.$$

4.3. **The linear terms.** All the remaining terms can be summarized by the following estimate, which can be proved by a stationary phase argument.

Claim C. Let $a, b \in \mathbb{N}_0$ such that $a - 2b \leq 1$. We write D_B^k as a schematic for a spatial differential operator of order k , such that any local coefficients $c(x)$ of D_B^k satisfy

$$\|c(x)\|_{C^m} \lesssim_{m,-B} B$$

Then for all $k \in \mathbb{N}_0 + \lambda_1 + 10$,

$$\sum_{l \in \mathbb{N}_0 + \lambda_1} \left\| P_k \left(D_B^a (-\Delta)^{-b} P_l w \right) \right\|_2 \lesssim_{a,b,-k} \frac{AB}{k^{r-7/4}}.$$

Proof. This is equivalent to proving that for any $(v_l)_{l \in \mathbb{N}_0 + \lambda_1}$ where $\|v_l\|_{L^2 M} \leq 1$ for all l , we have the bound

$$\begin{aligned} \sum_{l \in \mathbb{N}_0 + \lambda_1} \left| \left\langle \left\langle P_k \left(D_B^a (-\Delta)^{-b} P_l w \right), v_l \right\rangle \right\rangle \right| \\ = \sum_{l \in \mathbb{N}_0 + \lambda_1} \left| \left\langle \left\langle D_B^a (-\Delta)^{-b} P_l w, P_k v_l \right\rangle \right\rangle \right| \\ \lesssim^{-k} \frac{AB}{k^{r-7/4}}. \end{aligned} \tag{16}$$

To show (16), fix $\varepsilon \in (0, \frac{1}{2})$. Handling the “critical region” $[k - k^\varepsilon, k + k^\varepsilon]$ (where $l \sim_\varepsilon k$) is simple:

$$\begin{aligned} \sum_{l \in [k - k^\varepsilon, k + k^\varepsilon]} \left| \left\langle \left\langle D_B^a (-\Delta)^{-b} P_l w, P_k v_l \right\rangle \right\rangle \right| \\ \lesssim \sum_l l^{1/4} l^{a-2b} B \|P_l w\|_2 \\ \lesssim_\varepsilon \sum_l \frac{AB}{k^{r-a+2b-\frac{1}{4}}} \end{aligned}$$

$$\lesssim \frac{AB}{k^{r-a+2b-\frac{1}{4}-\varepsilon}},$$

where the last inequality follows from the observation that there are at most $O(k^\varepsilon)$ choices of l contributing to the summation. For the region away from k , we employ integration by parts to get arbitrary decay, as in the method of stationary phase.

Fix $m = m(\varepsilon, r, a) \in \mathbb{N}_1$ such that $\varepsilon(m-1) > r+a$. Observe that when $|l-k| > k^\varepsilon$, we can employ the Fourier trick:

$$\begin{aligned} & \left\langle \left\langle D_B^a (-\Delta)^{-b} P_l w, P_k v_l \right\rangle \right\rangle \\ &= \sum_{\substack{z_1 \in [0,1] \cap (\sigma(\sqrt{-\Delta}) - l) \\ z_2 \in [0,1] \cap (\sigma(\sqrt{-\Delta}) - k)}} \frac{1}{(l+z_1)^{2b}} \langle \langle D_B^a \pi_{l+z_1} w, \pi_{k+z_2} v_l \rangle \rangle \\ &= \sum_{z_1, z_2} \frac{1}{(l+z_1)^{2b}} \langle \langle \pi_{l+z_1} w, D_B^a \pi_{k+z_2} v_l \rangle \rangle \\ &= \sum_{z_1, z_2} \frac{1}{(l+z_1)^{2b}} \cdot \frac{1}{(k+z_2)^2 - (l+z_1)^2} \langle \langle \pi_{l+z_1} w, [D_B^a, -\Delta] \pi_{k+z_2} v_l \rangle \rangle. \quad (17) \end{aligned}$$

An induction argument now shows that

$$(17) = \sum_{z_1, z_2} \frac{1}{((l+z_1)^2)^b} \cdot \frac{1}{((k+z_2)^2 - (l+z_1)^2)^m} \langle \langle \pi_{l+z_1} w, D_B^{a+m} \pi_{k+z_2} v_l \rangle \rangle.$$

As in the proof of Lemma 9, we let $\Psi(z_1, z_2) = \frac{1}{((l+z_1)^2)^b} \cdot \frac{1}{((k+z_2)^2 - (l+z_1)^2)^m}$ and observe that

$$\|\Psi\|_{C^2([0,1]^2)} \lesssim_{\lambda_1} \frac{1}{l^{2b}} \cdot \frac{1}{(k^2 - l^2)^m} \lesssim_{\lambda_1, b} \frac{1}{(k^2 - l^2)^m}$$

So by the Fourier trick and Lemma 9, we conclude

$$\begin{aligned} & \left| \left\langle \left\langle D_B^a (-\Delta)^{-b} P_l w, P_k v_l \right\rangle \right\rangle \right| \\ & \lesssim_{M, m, -l, -k} \frac{1}{(k^2 - l^2)^m} k^{\frac{1}{4}} \|P_l w\|_2 k^{m+a} \|P_k v_l\|_2 B \\ & \lesssim_{\lambda_1} \frac{k^{m+a+1/4}}{(k^2 - l^2)^m} AB. \end{aligned}$$

We observe that, setting $z := l - k$,

$$\begin{aligned} \sum_{l \notin [k-k^\varepsilon, k+k^\varepsilon]} \frac{k^{m+a+1/4}}{(k^2 - l^2)^m} & \lesssim \int_{|z| > k^\varepsilon} \frac{k^{m+a+1/4}}{|2zk + z^2|^m} dz \\ & \lesssim \int_{|z| > k^\varepsilon} \frac{k^{a+1/4}}{|z|^m} dz \\ & \lesssim_m \frac{k^{a+1/4}}{k^{\varepsilon(m-1)}}. \end{aligned}$$

Because of the way we picked m , we conclude

$$\sum_{l \notin [k-k^\varepsilon, k+k^\varepsilon]} \left| \left\langle \left\langle D^a (-\Delta)^{-b} P_l w, P_k v_l \right\rangle \right\rangle \right| \lesssim_{M,r,a,b,-k} \frac{AB}{k^{r-7/4}},$$

which completes the proof of the claim. \square

APPENDIX A. REVIEW OF DIFFERENTIAL GEOMETRY

In this appendix we recall our conventions for some standard notation from differential geometry which we use throughout the paper. For any tensor $T_{a_1 \dots a_k}$, $(\nabla T)_{ia_1 \dots a_k} = \nabla_i T_{a_1 \dots a_k}$ and $\operatorname{div}_g T = \nabla^i T_{ia_2 \dots a_k}$.

Moreover,

$$(d\omega)_{ba_1 \dots a_k} = (k+1) \tilde{\nabla}_{[b} \omega_{a_1 \dots a_k]} \quad \forall \omega \in \Omega^k(M),$$

where $\tilde{\nabla}$ is any torsion-free connection,

$$(\delta\omega)_{a_1 \dots a_{k-1}} = -\nabla^b \omega_{ba_1 \dots a_{k-1}} = -(\operatorname{div}_g \omega)_{a_1 \dots a_{k-1}} \quad \forall \omega \in \Omega^k(M),$$

and

$$(\nabla_a \nabla_b - \nabla_b \nabla_a) T^{ij}_{kl} = -R_{ab\sigma}{}^i T^{\sigma j}_{kl} - R_{ab\sigma}{}^j T^{i\sigma}_{kl} + R_{abk}{}^\sigma T^{ij}_{\sigma l} + R_{abl}{}^\sigma T^{ij}_{k\sigma},$$

for any tensor T^{ij}_{kl} , where R is the Riemann curvature tensor and ∇ the Levi-Civita connection.

Similar identities hold for other types of tensors. When we do not care about the exact indices and how they contract, we can just write the schematic identity $(\nabla_a \nabla_b - \nabla_b \nabla_a) T^{ij}_{kl} = R * T$. As R is bounded on compact M , interchanging derivatives is a zeroth-order operation on M .

For any tensor field $T^{a_1 \dots a_k}_{b_1 \dots b_l}$ (and vector field X), the Lie derivative is given by

$$\begin{aligned} (\mathcal{L}_X T)^{a_1 \dots a_k}_{b_1 \dots b_l} &= X^c \nabla_c T^{a_1 \dots a_k}_{b_1 \dots b_l} - \sum_{i=1}^k T^{a_1 \dots c \dots a_k}_{b_1 \dots b_l} \nabla_c X^{a_i} \\ &\quad + \sum_{i=1}^l T^{a_1 \dots a_k}_{b_1 \dots c \dots b_l} \nabla_{b_i} X^c \end{aligned}$$

Then we have $\mathcal{L}_X (A \otimes B) = \mathcal{L}_X A \otimes B + A \otimes \mathcal{L}_X B$ for any tensor fields A, B .

Because ∇ is metric and torsion-free, we have

$$\mathcal{L}_X \langle Y, Z \rangle = \langle \nabla_X Y, Z \rangle + \langle Y, \nabla_X Z \rangle,$$

and

$$\nabla_X Y - \nabla_Y X = [X, Y] = \mathcal{L}_X Y.$$

We also have

$$d^2 = 0, \quad d\Delta_H = \Delta_H d, \quad \Delta_H \star = \star \Delta_H, \quad \mathcal{L}_X d = d\mathcal{L}_X,$$

as well as

$$\mathcal{L}_X \operatorname{vol} = \operatorname{div} X \operatorname{vol}, \quad \star 1 = \operatorname{vol}, \quad \star \operatorname{vol} = 1,$$

and

$$\begin{aligned} d\star &= (-1)^k \star d, \\ \delta\star &= (-1)^{k+1} \star d, \end{aligned}$$

$$\star\star = (-1)^{k(2-k)}$$

on $\Omega^k(M)$.

For tensor $T_{a_1 \dots a_k}$, define the Weitzenbock curvature operator by writing

$$\begin{aligned} \text{Ric}(T)_{a_1 \dots a_k} &= 2 \sum_{j=1}^k \nabla_{[i} \nabla_{a_j]} T_{a_1 \dots a_{j-1} \quad i \quad a_{j+1} \dots a_k} \\ &= \sum_j R_{a_j}{}^\sigma T_{a_1 \dots a_{j-1} \sigma a_{j+1} \dots a_k} - \sum_{j \neq l} R_{a_j}{}^\mu{}_{a_l}{}^\sigma T_{a_1 \dots \sigma \dots \mu \dots a_k} \end{aligned}$$

where $R_{ab} = R_{a\sigma b}{}^\sigma$ is the Ricci tensor. Then we have the Weitzenbock formula,

$$\Delta_H \omega = \nabla_i \nabla^i \omega - \text{Ric}(\omega)$$

for all $\omega \in \Omega^k(M)$, where $\nabla_i \nabla^i \omega = \text{tr}(\nabla^2 \omega)$ is also called the *connection Laplacian*, which differs from the Hodge Laplacian by a zeroth-order term. The geometry of M and differential forms are more easily handled by the Hodge Laplacian, while the connection Laplacian is more useful in calculations with tensors and the Penrose notation.

For tensors $T_{a_1 \dots a_k}$ and $Q_{a_1 \dots a_k}$, the tensor inner product is given by

$$\langle T, Q \rangle = T_{a_1 \dots a_k} Q^{a_1 \dots a_k}.$$

However, for $\omega, \eta \in \Omega^k(M)$, there is another dot product, called the Hodge inner product, where

$$\langle \omega, \eta \rangle_\Lambda = \frac{1}{k!} \langle \omega, \eta \rangle$$

So $|\omega|_\Lambda = \sqrt{\frac{1}{k!}} |\omega|$. We then define

$$\langle \langle \omega, \eta \rangle \rangle = \int_M \langle \omega, \eta \rangle \text{vol}$$

and

$$\langle \langle \omega, \eta \rangle \rangle_\Lambda = \int_M \langle \omega, \eta \rangle_\Lambda \text{vol}.$$

Recall that $\omega \wedge \star \eta = \langle \omega, \eta \rangle_\Lambda \text{vol}$ for all $\omega, \eta \in \Omega^k(M)$. Also, for all $\omega \in \Omega^k(M)$ and $\eta \in \Omega^{k+1}(M)$, we have

$$\langle \langle d\omega, \eta \rangle \rangle_\Lambda = \langle \langle \omega, \delta \eta \rangle \rangle_\Lambda.$$

Lastly,

$$\nabla_X(\star \omega) = \star(\nabla_X \omega),$$

and

$$|\star \omega|_\Lambda = |\omega|_\Lambda$$

for any $\omega \in \Omega^k(M)$, $X \in \mathfrak{X}(M)$.

We remark that the signs of Ric and Δ_H in the literature can differ according to various conventions commonly in use.

APPENDIX B. TRILINEAR ESTIMATE

In this appendix, we give the proof of Lemma 10. The arguments extend and generalize the proof of related results in [9]. We sketch the details for completeness. We begin with an integration-by-parts lemma.

Lemma 11. *For $i = 1, 2, 3, 4$, let $e_i \in C^\infty(M)$ be eigenfunctions where $(-\Delta)e_i = n_i^2 e_i$, and assume $n_1 \geq n_2 \geq n_3 \geq n_4 \geq 0$ and $n_1^2 \neq n_2^2 + n_3^2 + n_4^2$.*

Set $\mathcal{N} = \frac{1}{n_1^2 - n_2^2 - n_3^2 - n_4^2}$. Then, for any $a_1, a_2, a_3, a_4 \in \mathbb{N}_0$ and $m \in \mathbb{N}_1$, we have the schematic identity

$$\begin{aligned} & \int_M (\nabla^{a_1} e_2) * (\nabla^{a_2} e_2) * (\nabla^{a_3} e_3) * (\nabla^{a_4} e_4) \\ &= \mathcal{N}^m \sum_{\substack{b_2+b_3+b_4=2m \\ 0 \leq b_2, b_3, b_4 \leq m}} \int_M \nabla^{a_1} e_1 * \nabla^{a_2+b_2} e_2 * \nabla^{a_3+b_3} e_3 * \nabla^{a_4+b_4} e_4 \\ &+ \mathcal{N}^m \sum_{\substack{\sum_j c_j \leq \sum_j a_j + 2m - 2 \\ 0 \leq c_j \leq a_j + m - 1 \forall j \neq 1 \\ c_1 \leq a_1}} \int_M T_{mc_1 c_2 c_3 c_4} * \nabla^{c_1} e_1 * \nabla^{c_2} e_2 * \nabla^{c_3} e_3 * \nabla^{c_4} e_4 \end{aligned}$$

for some smooth tensors $T_{mc_1 c_2 c_3 c_4}$. We note that besides \mathcal{N} , there is no dependence on any n_i .

Proof. Recall that $\Delta f = \nabla_\alpha \nabla^\alpha f$ for any function f (α is an abstract index, not a natural number). Also recall that for any tensor T , $\nabla_\alpha \nabla^\alpha * \nabla^k T = \nabla^k * \nabla_\alpha \nabla^\alpha T + \nabla^k (R * T)$, where R is the Riemann curvature tensor and $\nabla^k (R * T) = \sum_{i=0}^k \nabla^i R * \nabla^{k-i} T$.

We then observe that

$$\begin{aligned} & n_1^2 \int_M \nabla^{a_1} e_1 * \nabla^{a_2} e_2 * \nabla^{a_3} e_3 * \nabla^{a_4} e_4 \\ &= \int_M \nabla^{a_1} (-\Delta) e_1 * \nabla^{a_2} e_2 * \nabla^{a_3} e_3 * \nabla^{a_4} e_4 \\ &= \int_M \nabla^{a_1} e_1 * (-\nabla_\alpha \nabla^\alpha) (\nabla^{a_2} e_2 * \nabla^{a_3} e_3 * \nabla^{a_4} e_4) \\ &+ \int_M \nabla^{a_1} (R * e_1) * \nabla^{a_2} e_2 * \nabla^{a_3} e_3 * \nabla^{a_4} e_4 \\ &= (n_2^2 + n_3^2 + n_4^2) \int_M \nabla^{a_1} e_1 * \nabla^{a_2} e_2 * \nabla^{a_3} e_3 * \nabla^{a_4} e_4 \\ &+ \sum_{\substack{b_2+b_3+b_4=2 \\ b_2, b_3, b_4 \leq 1}} \int_M \nabla^{a_1} e_1 * \nabla^{a_2+b_2} e_2 * \nabla^{a_3+b_3} e_3 * \nabla^{a_4+b_4} e_4 \\ &+ \sum_{c_j \leq a_j \forall j} \int_M T_{c_1 c_2 c_3 c_4} * \nabla^{c_1} e_1 * \nabla^{c_2} e_2 * \nabla^{c_3} e_3 * \nabla^{c_4} e_4 \end{aligned}$$

This yields

$$\begin{aligned}
& \int_M \nabla^{a_1} e_1 * \nabla^{a_2} e_2 * \nabla^{a_3} e_3 * \nabla^{a_4} e_4 \\
&= \mathcal{N} \sum_{\substack{b_2+b_3+b_4=2 \\ b_2, b_3, b_4 \leq 1}} \int_M \nabla^{a_1} e_1 * \nabla^{a_2+b_2} e_2 * \nabla^{a_3+b_3} e_3 * \nabla^{a_4+b_4} e_4 \\
&+ \mathcal{N} \sum_{c_j \leq a_j \forall j} \int_M T_{c_1 c_2 c_3 c_4} * \nabla^{c_1} e_1 * \nabla^{c_2} e_2 * \nabla^{c_3} e_3 * \nabla^{c_4} e_4 \quad (18)
\end{aligned}$$

On the other hand, for any smooth tensor T , we have

$$\begin{aligned}
& n_1^2 \int_M T * \nabla^{a_1} e_1 * \nabla^{a_2} e_2 * \nabla^{a_3} e_3 * \nabla^{a_4} e_4 \\
&= \int_M T * \nabla^{a_1} (-\Delta) e_1 * \nabla^{a_2} e_2 * \nabla^{a_3} e_3 * \nabla^{a_4} e_4 \\
&= (n_2^2 + n_3^2 + n_4^2) \int_M T * \nabla^{c_1} e_1 * \nabla^{c_2} e_2 * \nabla^{c_3} e_3 * \nabla^{c_4} e_4 \\
&+ \sum_{\substack{\sum_j c_j \leq \sum_j a_j + 2 \\ c_j \leq a_j + 1 \forall j \neq 1 \\ c_1 \leq a_1}} \int_M T_{c_1 c_2 c_3 c_4} * \nabla^{c_1} e_1 * \nabla^{c_2} e_2 * \nabla^{c_3} e_3 * \nabla^{c_4} e_4,
\end{aligned}$$

which gives

$$\begin{aligned}
& \int_M T * \nabla^{a_1} e_1 * \nabla^{a_2} e_2 * \nabla^{a_3} e_3 * \nabla^{a_4} e_4 \\
&= \mathcal{N} \sum_{\substack{\sum_j c_j \leq \sum_j a_j + 2 \\ c_j \leq a_j + 1 \forall j \neq 1 \\ c_1 \leq a_1}} \int_M T_{c_1 c_2 c_3 c_4} * \nabla^{c_1} e_1 * \nabla^{c_2} e_2 * \nabla^{c_3} e_3 * \nabla^{c_4} e_4. \quad (19)
\end{aligned}$$

Fix a_1, a_2, a_3, a_4 . We now use induction. To simplify notation, we write $A(s, t)$ for

$$\sum_{\substack{c_2+c_3+c_4=s \\ \max(c_2-a_2, c_3-a_3, c_4-a_4) \leq t \\ c_2 \geq a_2, c_3 \geq a_3, c_4 \geq a_4}} \int_M \nabla^{a_1} e_1 * \nabla^{c_2} e_2 * \nabla^{c_3} e_3 * \nabla^{c_4} e_4.$$

Similarly, we write $B(s, t)$ for any linear combination of terms $\int_M T * \nabla^{c_1} e_1 * \nabla^{c_2} e_2 * \nabla^{c_3} e_3 * \nabla^{c_4} e_4$ where $s \geq c_1 + c_2 + c_3 + c_4 - a_1$, $t \geq \max(c_2 - a_2, c_3 - a_3, c_4 - a_4)$, $c_1 \leq a_1$ and T is a smooth tensor.

Then (18) implies $A(s, t) = \mathcal{N}A(s+2, t+1) + \mathcal{N}B(s, t)$, while (19) implies $B(s, t) = \mathcal{N}B(s+2, t+1)$. A straightforward induction argument then gives

$$A(s, 0) = \mathcal{N}^m A(s+2m, m) + \mathcal{N}^m B(s+2m-2, m-1),$$

which was the desired claim. \square

Remark 12. Lemma 11 generalizes to an arbitrary number of functions. In fact, we only need the case of three functions (making $e_4 = 1$). In this case, the first term on the right hand side naturally simplifies to $\mathcal{N}^m \int_M \nabla^{a_1} e_1 * \nabla^{a_2+m} e_2 * \nabla^{a_3+m} e_3$.

We are ready to prove Lemma 10.

Proof of Lemma 10. Let $f_1, f_2, f_3 \in L^2(M)$; $a_1, b_1, a_2, b_2, a_3, b_3, J \in \mathbb{N}_0$ and $l_1 \geq l_2 \geq l_3 \geq \lambda_1(M)$ be such that $l_1 = l_2 + Kl_3 + 2$ for $K > 1$.

We pass to eigenspace projections, obtaining

$$\begin{aligned} & \int_M \left(\nabla^{a_1} (-\Delta)^{-b_1} P_{l_1} f_1 \right) * \left(\nabla^{a_2} (-\Delta)^{-b_2} P_{l_2} f_2 \right) * \left(\nabla^{a_3} (-\Delta)^{-b_3} P_{l_3} f_3 \right) \\ &= \sum_{\substack{z_j \in [0,1) \cap (\sigma(\sqrt{-\Delta}) - l_j) \\ j=1,2,3}} \left[\left(\prod_{i=1,2,3} \frac{1}{(l_i + z_i)^{2b_i}} \right) \right. \\ & \quad \left. \cdot \left(\int_M \nabla^{a_1} \pi_{l_1+z_1} f_1 * \nabla^{a_2} \pi_{l_2+z_2} f_2 * \nabla^{a_3} \pi_{l_3+z_3} f_3 \right) \right]. \quad (20) \end{aligned}$$

Invoking Lemma 11, and setting

$$\Psi(z_1, z_2, z_3) := \left(\prod_{i=1,2,3} \frac{1}{(l_i + z_i)^{2b_i}} \right) \frac{1}{\left((l_1 + z_1)^2 - (l_2 + z_2)^2 - (l_3 + z_3)^2 \right)^J},$$

we see that the right-hand side of (20) is equal to

$$\begin{aligned} & \sum_{\substack{z_j \in [0,1) \cap (\sigma(\sqrt{-\Delta}) - l_j) \\ j=1,2,3}} \Psi(z_1, z_2, z_3) \\ & \cdot \left(\int_M \nabla^{a_1} \pi_{l_1+z_1} f_1 * \nabla^{a_2+J} \pi_{l_2+z_2} f_2 * \nabla^{a_3+J} \pi_{l_3+z_3} f_3 \right. \\ & \quad \left. + \sum_{(c_1, c_2, c_3) \in \Xi} \int_M T_{Jc_1c_2c_3} * \nabla^{c_1} \pi_{l_1+z_1} f_1 * \nabla^{c_2} \pi_{l_2+z_2} f_2 * \nabla^{c_3} \pi_{l_3+z_3} f_3 \right), \end{aligned}$$

where

$$\begin{aligned} \Xi := & \left\{ (c_1, c_2, c_3) : \sum_j c_j \leq \sum_j a_j + 2J - 2, \right. \\ & \left. 0 \leq c_j \leq a_j + J - 1 \forall j \neq 1, \text{ and } c_1 \leq a_1 \right\}. \end{aligned}$$

Now, note that

$$\begin{aligned} l_1^2 - (l_2 + 1)^2 - (l_3 + 1)^2 &= (K^2 - 1) l_3^2 + 2 + 2Kl_2l_3 + 2l_2 + (4K - 2) l_3 \\ &\gtrsim \max_{i=1,2,3} (l_i + 1). \end{aligned}$$

As a consequence,

$$\|\Psi\|_{C^2([0,1]^3)} \lesssim_{\lambda_1} \left(\prod_{i=1,2,3} \frac{1}{l_i^{2b_i}} \right) \frac{1}{(Kl_2l_3)^J}.$$

By the Fourier trick and Proposition 8, we bound the right-hand side of (20) by

$$\left(\prod_{i=1,2,3} \frac{1}{l_i^{2b_i}} \right) \frac{1}{(Kl_2l_3)^J} l_1^{a_1} \|P_{l_1} f_1\|_2 l_3^{1/4} l_2^{a_2+J} \|P_{l_2} f_2\|_2 l_3^{a_3+J} \|P_{l_3} f_3\|_2,$$

where we have used the fact that

$$\begin{aligned} \|\nabla^{a_1} P_{l_1} f_1\|_2 &\lesssim \|P_{l_1} f_1\|_{H^{a_1}} \\ &\sim \left\| (-\Delta)^{a_1/2} P_{l_1} f_1 \right\|_2 \\ &\sim_M l_1^{a_1} \|P_{l_1} f_1\|_2. \end{aligned}$$

This completes the proof of the lemma. \square

REFERENCES

- [1] V. Arnold. Sur la Géométrie Différentielle des Groupes de Lie de dimension infinie et ses applications à l'hydrodynamique des fluides parfaits. *Ann. Inst. Fourier* 16 (1966), no. 1, 319–361.
- [2] N. Burq, P. Gérard and N. Tzvetkov. Multilinear eigenfunction estimates and global existence for the three dimensional nonlinear Schrödinger equations. *Ann. Sci. École Norm. Sup.* (4) 38 (2005), no. 2, 255–301.
- [3] C.H. Chan, M. Czubak and M. Disconzi. The formulation of the Navier-Stokes equations on Riemannian manifolds. *J. Geom. Phys.* 121 (2017), 335–346.
- [4] M. Christ. On the regularity of inverses of singular integral operators. *Duke Math. J.* 57 (1988), no. 2, 459–484.
- [5] C. Cao, M.A. Rammaha, and E.S. Titi. The Navier-Stokes equations on the rotating 2D sphere: Gevrey regularity and asymptotic degrees of freedom. *Z. Angew. Math. Phys.* 50 (1999), no. 3, 341–360.
- [6] C. Cao, M.A. Rammaha, and E.S. Titi. Gevrey Regularity for Nonlinear Analytic Parabolic Equations on the Sphere. *J. Dyn. Diff. Eq.* 12 (2000), no. 2, 411–433.
- [7] D.G. Ebin and J. Marsden. Groups of Diffeomorphisms and the Motion of an Incompressible Fluid. *Ann. of Math* 92 (1970), no. 1, 102–163.
- [8] H. Fujita and T. Kato. On the Navier-Stokes initial value problem, I. *Arch. Ration. Mech. Anal.* 16 (1964), no. 4, 269–315.
- [9] Z. Hani. Global well-posedness of the cubic nonlinear Schrödinger equation on closed manifolds. *Comm. Partial Differential Equations* 37 (2012), no. 7, 1186–1236.
- [10] Z. Hani. Personal communication.
- [11] K.M. Huynh. Hodge-Theoretic Analysis on Manifolds with Boundary, Heatable Currents, and Onsager's Conjecture in Fluid Dynamics. Preprint (2019), arXiv:1907.05360.
- [12] M.H. Kobayashi. On the Navier-Stokes equations on manifolds with curvature. *J. Eng. Math.* 60 (2008), no. 1, 55–68.
- [13] O. Ladyzhenskaya, *The Mathematical Theory of Viscous Incompressible Flows*, 2nd edition, Gordon and Breach, New York, 1969.
- [14] J.M. Lee. *Manifolds and Differential Geometry*. Grad. Studies in Math. v. 107, Amer. Math. Soc., Providence, RI, 2009.
- [15] J.C. Mattingly and Ya G. Sinai. An Elementary Proof of the Existence and Uniqueness Theorem for the Navier-Stokes Equations. *Commun. Contemp. Math.* 1 (1999), no. 4, 497–516.
- [16] M. Mitrea and M. Taylor. Navier-Stokes equations on Lipschitz domains in Riemannian manifolds. *Math. Ann* 321 (2001), no. 4, 955–987.
- [17] J. Pruess, G. Simonett, and M. Wilke. On the Navier-Stokes equations on surfaces. Preprint (2020), arXiv:2005.00830.

- [18] G. Schwarz. Hodge Decomposition—A Method for Solving Boundary Value Problems. Lect. Notes in Math. Vol. 1607, Springer, Berlin, Heidelberg, 1995.
- [19] M.E. Taylor. Partial Differential Equations I: Basic Theory. Applied Math. Sciences, Vol. 115, Springer New York, New York, NY, 2011.
- [20] M.E. Taylor. Partial Differential Equations III: Nonlinear Equations. Applied Math. Sciences, Vol. 117, Springer New York, New York, NY, 2011.
- [21] R.M. Wald. General Relativity. Univ. of Chicago Press, Chicago, IL, 1984.

(A. Bulut) DEPARTMENT OF MATHEMATICS, LOUISIANA STATE UNIVERSITY

E-mail address: `aynurbulut@lsu.edu`

(K.M. Huynh) DEPARTMENT OF MATHEMATICS, UNIVERSITY OF CALIFORNIA, LOS ANGELES

E-mail address: `hmkhang24@math.ucla.edu`