

Observing a Moving Target - Reliable Transmission of Debug Logs from Embedded Mobile Devices

Björn Daase, Leon Matthes, Lukas Pirl, Lukas Wenzel
Hasso Plattner Institute, University of Potsdam, Germany
{bjoern.daase, leon.matthes}@student.hpi.de, {lukas.pirl, lukas.wenzel}@hpi.de

Abstract—Mobile embedded devices of the Internet of Things (IoT) face tight resource constraints and uncertain environments, including energy scarcity and unstable connectivity. This aggravates debugging, optimization, monitoring, etc.; for which logging information must be accessible throughout all phases of development and product life cycles.

This work compares approaches for transmitting logs with regard to application requirements (e.g., bandwidth), resource consumption (e.g., memory), operating constraints (e.g., power supply), and the medium (e.g., UART, WiFi). A qualitative comparison suggests that the adequacy of approaches depends on the concrete application and the phase in the life cycle.

We report from our case study, where the embedded mobile device is represented by a self-driving slot car (*Carrera D132*). With this target device, failure logs, new firmware, and monitoring data need to be exchanged. The gathered experiences support our qualitative discussion: Wireless techniques can suit the needs of many phases in the life cycle but it is particularly evident that energy consumption is crucial. With a loaded wireless stack and while transmitting logs, the car's operating voltage drop within a ~20 ms power interruption is ~1.6 times higher. This limits communication flexibility significantly.

I. INTRODUCTION

With over 90% of all processors these days being part of embedded devices [1], [2], [3], developing and operating these kind of devices is a major area of responsibility. A large part of the development and operation is finding and resolving defects (commonly referred to as *bugs*), performance bottlenecks, or device health problems. For the sake of readability, this work refers to all of the aforementioned activities as *debugging*.

Debugging is not only limited to the development process, but includes many phases during the life cycle of the device. However, each phase during the life cycle of the devices presents different debugging scenarios with different characteristics and constraints. For example, the development process on the one hand and monitoring in production on the other hand have completely different challenges (i.e. easily adaptable debugging vs. constant debugging output).

The deeper a device is embedded, the harder the debugging. While common debugging tools require physical access to the device to transfer debug logs, deeply embedded devices are normally not physically accessible [4]. The situation is even more difficult when the embedded device is also mobile.

In this work, we focus on exploring different debugging techniques for embedded mobile devices. We also analyze how these techniques map to different phases of the devices' life cycle and how they can improve the debugging experience. To

assess their applicability in practice, we are conducting a case study with self-driving slot cars. In addition to the analysis and case study report, we confirm previous research [5] in that the lab setting is suited for imitating real-world challenges regarding embedded devices development and operation.

II. BACKGROUND AND RELATED WORK

In this section, we first give an overview of the challenges when debugging mobile embedded devices in Section II-A. Section II-B describes the various scenarios that are derived from the different facets of debugging. Constraints imposed by embedded mobile devices are outlined in Section II-C.

A. Debugging Mobile Embedded Devices

Debugging embedded systems is known to be a challenging task [6], often also adding up constraints from, e.g., (hard) real-time and distributed systems [7]. In the past, researchers analyzed the debugging of embedded systems in various contexts, e.g., especially on ships [8], for wireless embedded networks [9], or multimedia applications [10]. As these domains highly differ, the understanding of what debugging includes is different [11] as well. This suggests to group debugging scenarios into different categories with specific requirements.

Data transmission is the key to debugging, as only through communication device states can be determined and diagnosed [12]. The communication technologies commonly used for embedded devices tend to be different and more diverse compared to those of larger computer systems [13]. Aspects such as resource consumption and timing behavior tend to be of stronger concern than, e.g., throughput. At the same time, the wide variety of communication technologies used in embedded systems can be considered characteristic. In the past, both wired and wireless transmission technologies have been used for transmitting data from embedded devices [13], [14]. Regarding wireless transmission, there is a large body of research on Bluetooth and WiFi [14], [15]. Especially for WiFi, extensive experiments on the energy consumption have already been carried out [16].

Mobile embedded devices are increasingly deployed in mission-critical applications [17]. The mobility of these devices yields two major challenges: First, mobile embedded devices normally do not have stable energy supply. Therefore, the energy usage might impact the performance of the system. At least transiently, energy capacities might be reduced or even too little to keep a system functional [18]. Second, not every

arXiv:2110.01412v1 [cs.DC] 29 Sep 2021

transmission technology is suitable for every environment. While there is a lot of research focusing on the security of embedded mobile devices [17], [19], [20], choosing an adequate transmission technology is also dependent on the environment, specifically on energy requirements.

B. Debugging Scenarios

Previous research on debugging embedded systems has focused in particular on the development cycle performed by hardware and software developers [21], [22], [23], [24]. However, as Hailpern et al. point out [11], debugging is not limited to software development, but also extends into other parts of the development cycle, including production. All these different activities require their own capabilities to allow for effective debugging. In this section, we highlight the core activities during which debugging capabilities are required and characterize the requirements a debugging solution must fulfill respectively.

Software Development: During development, debugging is essential to ensure that the code developers write does not contain any faults [11]. Developers need to conduct experiments to see how the target platform reacts to certain commands and operating states. During development, the code changes frequently, required debugging output changes frequently, and every hour of development is expensive. Hence, debugging facilities must be straightforwardly available, easily adaptable, and allow for quick code iteration [25].

Optimization: Optimization usually takes place in the late stages of development. This is an especially important phase in embedded systems development, where hardware and software tend to be closely coupled. The hardware is typically close to production-ready, so optimization efforts can take hardware-specifics into account. The Software is typically already functional but needs to fulfill tighter resource constraints. As a result, the analysis focuses on identifying capacity and performance bottlenecks as code changes become less frequent [26]. Therefore, the debugging instrumentation should have a small and predictable runtime impact. Ideally, the debugging and optimization techniques are useful for (hard) real-time systems as those systems require minimal impact on program behavior.

Monitoring: During and after development, gaining insight into the embedded system's state is important to identify misbehaving products and unexpected environmental influences. For this reason, constantly monitoring certain aspects of embedded devices is necessary [27]. This can include the state of sensors, power consumption, and battery levels. During development, this data should also be available quickly, ideally in a continuous stream. In production, monitoring could be limited to sending aggregated reports automatically in intervals or locally logging monitoring data for later access in the event of an unexpected behavior of the device. Continuous output is usually not necessary in these scenarios.

Operational Status: The operational status can be derived from monitoring data. It summarizes the condition the device is in (such as commands executed, resource usage, and data files) [28]. This status needs to be reported quickly, as it can

indicate a problem with the device or even dangerous operating conditions. In this scenario, low latency is important, whilst throughput is of lesser concern.

Fault in Production: Despite the best efforts of developers, a defects in the code might still reach production. As it is unavoidable for humans to err, responsible developers must take measures to be able to detect and debug faults even in production code [11]. At this point, the distance (physical, as well as virtual) to the device can be challenging. In case the developer is unable to access a device physically, sending monitoring, crash report, and status data must be completely automated or take steps to make it easy for the user to do so.

C. Debugging Constraints

Embedded devices are characterized by low computational power as well as little memory availability. In the case of mobile embedded devices, energy consumption must also be considered. This is especially a concern for battery-operated devices, since an increase in the calculation effort always entails an increased energy consumption. Moreover, mobile embedded devices might not always be physically accessible, which can limit the duration, time, and position for debug log transfer. Furthermore, if such a device is used in a (hard) real-time system, predictability is also required.

III. DEBUGGING TECHNIQUES COMPARISON

In Section II-A, we described that embedded devices can be differentiated by the used communication medium. Nowadays, this is mainly a differentiation between the use of wired or wireless transmission media. Furthermore, in mobile embedded devices, the availability of such communication medium as well as the energy supply require an additional differentiation between a continuous or periodic data transmission. Therefore, in this section, we derive a matrix of debugging techniques from the given constraints in Section II-C.

We subdivide the available debugging techniques for an embedded device in four categories along the axes of communication media, as well as their availability. For each of the four categories, debugging techniques are introduced and assessed qualitatively. A case study that evaluates these four techniques on the example of self-driving slot cars will be presented in the subsequent Section IV.

1) *Periodic Wired Transmission:* In this case, a stable wired transmission is available only during limited periods of time or in certain operating conditions. It requires saving debugging logs until the wired connection is available. This results in an increased memory and storage consumption. Additionally, an increased computational resources are required whenever the connection becomes available.

The low computational overhead during logging makes it especially applicable for optimization purposes. The typically low setup and implementation efforts needed for implementing a wired transmission, makes it applicable for early stages of development as well.

A real-world scenario could be a solar-powered environmental sensor where the energy supply is not sufficient for

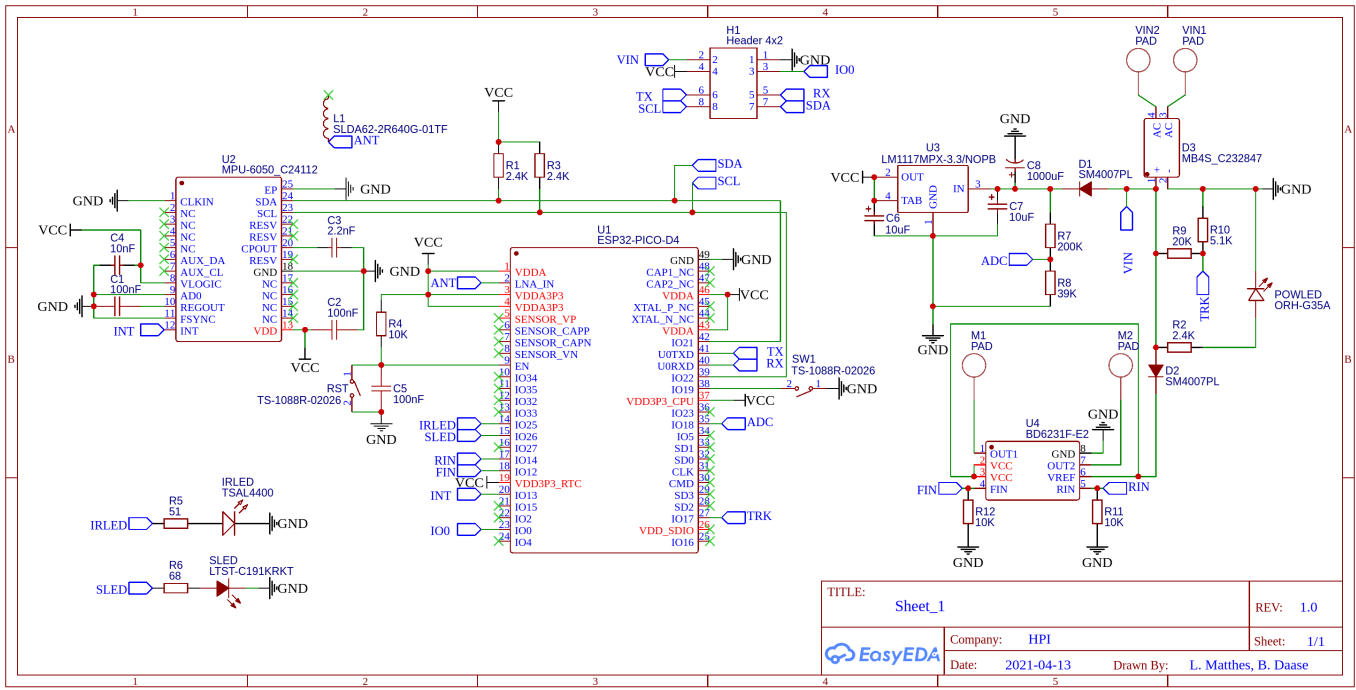

Figure 1: Circuit diagram of the controller for the slot car.

wireless transmission but where personnel regularly plugs in to collect data.

2) *Periodic Wireless Transmission:* When wireless transmission media are available, however not continuously or stable, then the use of periodic wireless transmission is applicable. Again, this requires saving debugging logs until wireless communication is established. Therefore, more memory and storage is required, as well as additional computational overhead when establishing a wireless connection and transmitting. Especially the setup and teardown of the wireless communication stack (e.g., WiFi/Bluetooth) can incur a significant overhead [29].

Especially in a development environment, the periodic wireless transmission can be stably ensured which makes this technique usable for remote software development. Likewise, due to the low overhead when not transmitting, this technique can be suitable for optimization as well. The ease of use and widespread adoption of wireless technologies, makes this technique usable also in production for transmitting failure reports alike.

In the real world, wearable devices, such as smart health trackers or smart watches fit in this category, as they often require proximity to the home network or a smartphone for internet access.

3) *Continuous Wired Transmission:* For this technique, continuous access to a wired connection must be ensured. Generally, this case is characterized by low, constant overhead, as minimal data needs to be saved and wired transmission stacks are typically less resource intensive than wireless equivalents. Because the physical setup of a new infrastructure just for the transfer of debugging logs is expensive and often infeasible, existing infrastructure is typically reused for this purpose (e.g.,

power lines).

The overall low overhead makes this technique satisfactory for monitoring and operational status. These require continuous but small data transfers. Additionally, the low overhead makes it usable for optimization purposes as long as the limited data rates are sufficient.

Whilst this case is theoretically possible, it is also the most unlikely to occur in practice, as it would require continuous access to a mobile device via a wired transmission medium. However, one such case could be the transmission of data using the contact wire of a railway track.

4) *Continuous Wireless Transmission:* Wireless transmission normally has the advantage that it always available, despite the fact that the device is on the move. On the flip side, the continuous operation of the wireless stack is compute and thus energy intensive. However, data does not have to be stored for extended periods on the device.

The continuous connection is especially advantageous when transmitting monitoring and operational status data. If stable wireless transmission can be ensured, this technique is applicable for development purposes. Due to its ease of access it encourages faster development cycle times that improve quality of development [25]. Furthermore, a failure in production can be easily reported, as wireless transmission is more and more part of production deployments.

This makes it usable, e.g., for smartphones that provide continuous access to wireless (including cellular) networks.

IV. CASE STUDY - SELF-DRIVING SLOT CAR DEBUGGING

Previous research has shown that there is often a significant difference between theoretical and experimental results for transmission communication media [30]. Therefore, we first

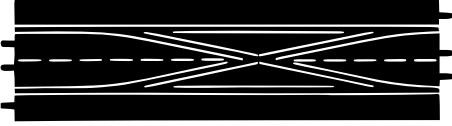

Figure 2: Double lane change track segment.

describe our experiment setup using slot cars in Section IV-A and explicitly highlight the energy consumption constraints of our experiment in Section IV-B. Then, we apply the techniques described in Section III to our slot car in Section IV-C. Finally, Section IV-D evaluates the different approaches.

A. Experiment Setup

In a setup similar to previous research [5], we use a digital Carrera D132 race track which resembles an environment with typical aspects for the development of mobile embedded devices. To test the techniques described in Section III, we develop a custom slot car controller based on the ESP32 microcontroller. This allows us to run custom code, whilst moving on a slot car track, to simulate a remote, mobile, and difficult to reach environment.

Initially, we connect multiple development boards on a board for hardware prototyping (i.e., *perfboard*). This setup is easy to program and communicate with, using the built-in USB port of the ESP development board. It is a typical prototyping scenario for embedded devices. The later revision, shown in Figure 1, is implemented as a custom Printed Circuit Board (PCB) with all components integrated and UART access for programming and debugging. The hardware shows that even relatively simple problems require relatively complex hardware solutions. Due to the complexity, purely theoretical considerations can no longer fully cover the functionality in interaction with environmental influences. We assume that this board resembles a product close to market, where development and debugging access is more difficult. Especially because this PCB fits into the chassis of a Carrera slot car, reaching the UART port requires disassembling the car even in the lab.

The slot car is continuously supplied with power over two metal rails except on lane change segments, where the rails are interrupted as shown in Figure 2. On these segments, the slot cars must drive (i.e., roll) up to ~ 6 cm without power supply. These power interruptions must be taken into account when programming the microcontroller, as the running program has a relevant impact on power consumption.

The overall aim of the development is a self-driving slot car. During the development logging data and firmware needs to be exchanged between the slot car and the development host. During the power interruptions on lane change segments, energy is limited to the capacity of a 1000 μF capacitor. The car can sustain normal operation of the microcontroller (clock speed 80 MHz, no WiFi) for up to 100 ms. Motor power is cut off during these segments, as the motor control is separate from the ESP’s power circuitry.

B. Energy Consumption

The energy consumption of the ESP32 is influenced by multiple factors. During the crossing of a lane change segment, it

	No WiFi	Not Sending	Sending
80 MHz	1.62 V	1.91 V	2.64 V
160 MHz	2.11 V	2.20 V	2.82 V
240 MHz	2.49 V	<i>n/a</i>	<i>n/a</i>

Table 1: Maximum observed capacitor voltage drop.

needs to be tightly controlled, as no power supply is available. Apart from putting the microcontroller into a sleep mode that prohibits calculation, changing the operating frequency, and limiting the use of wireless communication has a significant impact on the consumed power.

Figure 3 illustrates the supply and capacitor voltages during the two power interruptions of a lane change segment (at ~ 30 ms and ~ 120 ms). The first row, represents the microcontroller operating at 80 MHz clock frequency, the second at 160 MHz. Individual columns represent (from left to right) operation without the WiFi stack active, with the WiFi stack active but not sending, as well as WiFi active and sending. The microcontroller is forced to send in column three by repeatedly requesting data from it. As the supply voltage also encodes the Carrera digital communication protocol, as described in Section IV-C3, it fluctuates even during normal operation. The maximum observed capacitor voltage drop in all scenarios is shown in Table 1. Where the microcontroller consistently failed operation due to brownouts, *n/a* is listed.

Should the capacitor voltage drop below 5 V at any point, the microcontroller and its peripherals would brownout and need to reboot. As a consequence, data stored non-permanently would be lost and the autonomous drive would be impaired. It is apparent that these voltage drops need to be tightly controlled to avoid the microcontroller from crashing.

As also shown in previous work [31] and hence expected, operating frequency influences the rate at which the voltage of the capacitor drops. Furthermore, only enabling WiFi in receiving mode, without sending data already slightly increases energy consumption. Sending WiFi signals is the most problematic scenario as demonstrated in Figure 3 c) and f). The capacitor voltage drops rapidly in both instances for a very short period of time. This happens when the microcontroller answers a request from the development host exactly during the first power interruption in both figures. When using the microcontrollers maximum frequency of 240 MHz, power consumption is increased again, as shown in Figure 4. The use of WiFi at this frequency is infeasible as the car could not cross a lane change with 240 MHz clock speed and WiFi enabled without rebooting.

C. Debugging Technique Application

This section describes the application of the debugging techniques described in Section III. After an introductory description of each technique, we discuss their characteristics, give a recommendation for fitting debugging scenarios from Section II-B, and finally evaluating them.

1) Save and Print Later (Periodic Wired Transmission):

While driving, the slot car continuously measures data and writes it to internal flash memory. After a certain period of time, the car stops at a predefined point (e.g., at start/finish

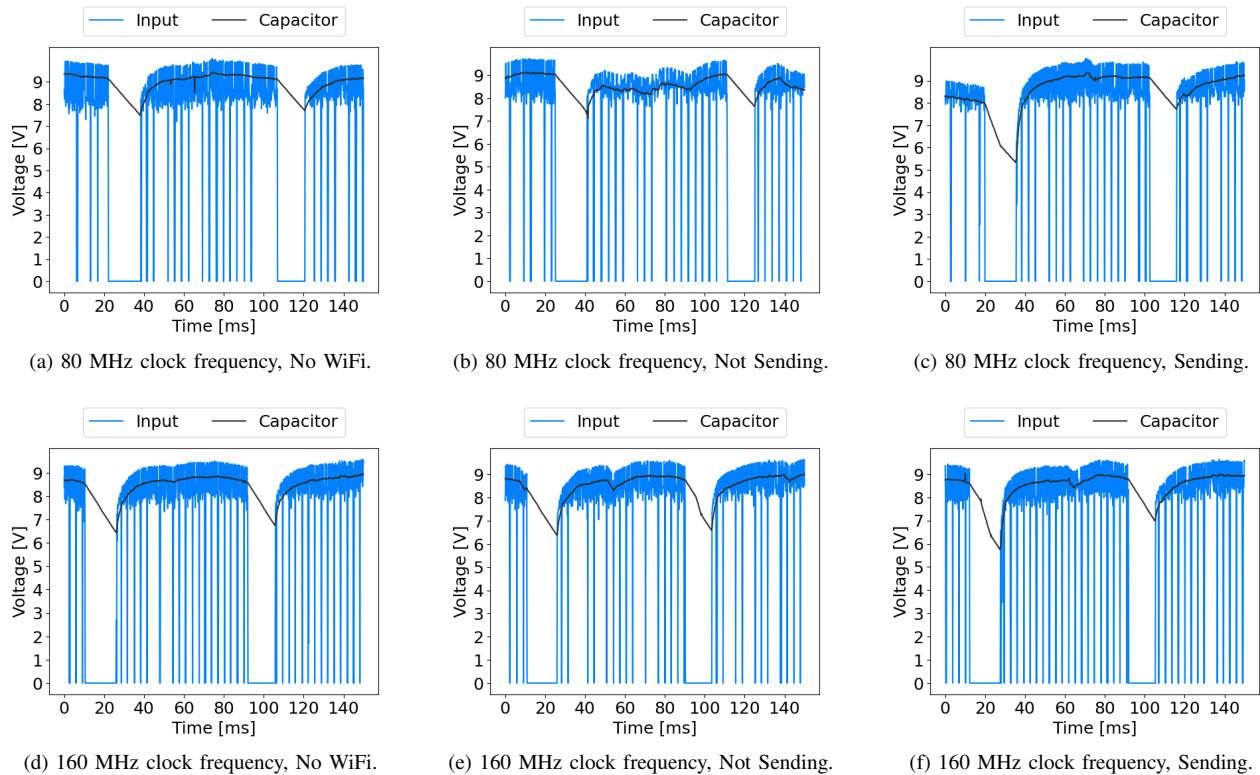

Figure 3: Continuous voltage readout of the track (input) and of the capacitor.

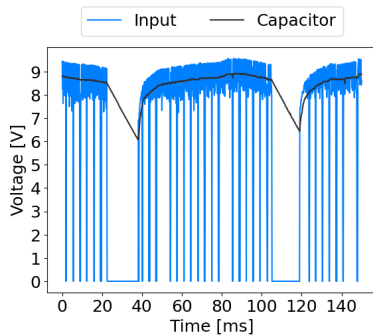

Figure 4: 240 MHz clock frequency, No WiFi.

line) and is connected to a read-out device (usually a laptop computer) via a cable. Then, the car transmits its data via the cable. At this point there is also the option to reprogram the car. When finished, the cable is disconnected, the car deletes the stored data and drives off again.

Advantages

- Known method — easy to set up
- Low runtime performance impact
- Very low risk of interruption/data corruption

Shortcomings

- Stopping not possible everywhere, some parts of track not accessible
- Needs physical access, which is difficult inside chassis and UART header is difficult to connect to
- Stopping interrupts normal operation — possibly infeasible in production

- Data must be saved whilst driving

Evaluation Overall, "Save and Print Later" is a very simple and reliable form of transferring data from the car as well as uploading firmware to the car. On the other hand, physical access to the board in the car is required. The deeper a device is embedded, the more difficult it becomes, and size restrictions also limit the use of the transmission technology. Therefore it is only a useful solution for early phases in development, where a USB port might exist on the board, and no disassembly is required to reach the data lines.

2) *Stop and Radio (Periodic Wireless Transmission)*: "Stop and Radio" also saves data continuously in order to be able to stop and transfer the data at once. At this point, it is also possible to reprogram the car. However, the periodic transmission happens wirelessly via the ESP32's built-in 2.4 GHz wireless capabilities (WiFi 802.11 b/g/n, Bluetooth v4.2 and BLE). The whole stop/transmission/drive off process now requires no physical access to the device.

Advantages

- Stopping possible anywhere on track (except lane changes)
- Virtually unlimited energy available, making the transmission time irrelevant
- Updates and development are possible
- Low risk of interruption
- Low runtime performance impact

Shortcomings

- Device needs to know when to stop — physical access might be necessary to, e.g., push a button
- Stopping interrupts normal operation — possibly infeasible in production
- WiFi has high flash and RAM memory consumption
- Data must be saved whilst driving

Evaluation Altogether, ”Stop and Radio” trades off memory and compute power for not having to access the device physically compared to ”Save and Print Later”. This makes it especially useful for Over-the-Air (OTA) updates and development, especially at later stages of development.

3) *Write to Carrera Track (Continuous Wired Transmission)*: The Carrera digital slot cars are constantly communicating with the control unit of the track via the tracks’ power rails using a digital communication protocol. This way, multiple cars can be in contact with the same rails and can still be individually controlled. Slot cars can also send some data back, a feature that is usually used by the car to indicate that it reached a sensor. There is, however, a possibility that these data packets could be hijacked to send custom data, as much as the protocol allows, back onto the track. This data could then be read and interpreted by a custom decoder, implementing a continuous, wired transmission.

The advantage would be a constant, reliable data output that is less subject to interference, like a radio signal might be. Using this technique, data to be transferred would not have to be saved for extended periods of time but can be sent with minimal delay. According to the research by Heß [32], cars can send up to 13 bits, 8 times per 75 ms cycle.

$$\frac{1}{0.075 \text{ s}} \cdot 8 \cdot 13 \text{ Bit} \approx 1,387 \frac{\text{Bit}}{\text{s}}$$

This results in a theoretical bandwidth of $\approx 1,387 \text{ Bit/s}$.

Advantages

- Continuous output
- Position on track does not matter (except lane changes)

Shortcomings

- Necessary to adhere to Carrera Digital protocol [32]
- Low bandwidth
- Difficult to set up — hardware changes needed on both ends

Evaluation In the end, writing to the Carrera track is difficult to set up, both for developers and potential users and offers only extremely limited bandwidth. Furthermore, for any mobile embedded devices, similar options are not even available. Mainly for this reason, we did not implement this option.

4) *WiFi On-the-fly (Continuous Wireless Transmission)*:

As wireless transmission is possible from anywhere on a slot car track, it allows for a continuous, direct connection to the slot car. This way, debug output can be sent at all times and from anywhere on the track. This is similar to writing to the Carrera track but using a wireless medium. The challenge with this technique is its high power consumption and performance impact, as analyzed by Pötsch et al. [16]. Hence, energy consumption (here, crossing lane change segments) needs special consideration.

Advantages

- Continuous output
- Position on track does not matter
- OTA updates and development possible

Shortcomings

- High power consumption
 - Problematic on lane changes
 - Unpredictable spikes in power consumption on send
- High memory consumption of WiFi stack
- WiFi-stack always active — can have a runtime impact
- OTA updates might be interrupted
 - Ejection from track, power loss on lane changes
 - Measures against data corruption necessary

Evaluation This is the most versatile and convenient option, useful for almost any kind of debugging. However, high energy consumption, memory usage, and more advanced setup make it the most resource intensive way of communication. Special precautions must be taken to prevent the microcontroller from consuming too much power, when only limited energy is available. In the worst case these power interruptions could result in corrupted data or even a corrupted flash image.

D. Evaluation

Our experiment supports the debugging trade-offs identified in Section III. Though being widely and easily available on most microcontroller platforms, wired transmission of debug logs via UART or USB bridges present significant practical issues: During the intended mode of operation, the device (i.e., the slot car) is moving. Therefore, attaching cables is either impossible or distorts the operational characteristics, precluding optimization or production scenarios. Our particular experiment setup allows a loophole by allowing continuous data transmission by modulation over the track power supply. However, the strict bandwidth limits would limit this approach to rare and compact status reports.

In contrast, wireless transmission of debug messages offers a much broader field of feasible application scenarios. High bandwidths leave enough room for large volumes of sensor data for optimization purposes and verbose status messages during early application development. The only distorting factor on the devices normal operating conditions is the significant power consumption of radio modules. However, our experiment shows that careful energy budgeting and adaptive control of power states can overcome this obstacle and avoid interference between the regular device operation and the debugging subsystem.

V. CONCLUSION AND FUTURE WORK

The increased accessibility of deeply embedded IoT devices to a wider audience of application developers calls for more sophisticated and convenient debugging techniques.

In this paper we argue for an increased focus on wireless debugging techniques. They can offer a high degree of flexibility and convenience. To unleash this potential, the readily

available hardware modules require better and more adaptive instrumentation.

Further research is required to develop techniques to automatically control the timing of transmissions and selection of power states based on a configurable energy budget.

REFERENCES

- [1] S. Schulz, J. W. Rozenblit, and K. Buchenrieder, "Multilevel testing for design verification of embedded systems," *IEEE Des. Test Comput.*, vol. 19, no. 2, pp. 60–69, 2002. [Online]. Available: <https://doi.org/10.1109/54.990443>
- [2] W. Haberl, M. Herrmannsdoerfer, J. Birke, and U. Baumgarten, "Model-level debugging of embedded real-time systems," in *10th IEEE International Conference on Computer and Information Technology, CIT 2010, Bradford, West Yorkshire, UK, June 29-July 1, 2010*. IEEE Computer Society, 2010, pp. 1887–1894. [Online]. Available: <https://doi.org/10.1109/CIT.2010.323>
- [3] M. Broy, "Automotive software and systems engineering (panel)," in *3rd ACM & IEEE International Conference on Formal Methods and Models for Co-Design (MEMOCODE 2005), 11-14 July 2005, Verona, Italy, Proceedings*. IEEE Computer Society, 2005, pp. 143–149. [Online]. Available: <https://doi.org/10.1109/MEMCOD.2005.1487905>
- [4] S. Mohan, "Worst-case execution time analysis of security policies for deeply embedded real-time systems," *SIGBED Rev.*, vol. 5, no. 1, p. 8, 2008. [Online]. Available: <https://doi.org/10.1145/1366283.1366291>
- [5] D. Richter, A. Grapentin, and A. Polze, "Mobility-as-a-service: A distributed real-time simulation with carrera slot-cars," in *IEEE 18th International Symposium on Real-Time Distributed Computing, ISORC 2015, Auckland, New Zealand, 13-17 April, 2015*. IEEE Computer Society, 2015, pp. 276–279. [Online]. Available: <https://doi.org/10.1109/ISORC.2015.19>
- [6] C. MacNamee and D. Heffernan, "Emerging on-ship debugging techniques for real-time embedded systems," *Computing & Control Engineering Journal*, vol. 11, no. 6, pp. 295–303, 2000.
- [7] J. A. Stankovic, "Real-time and embedded systems," *ACM Comput. Surv.*, vol. 28, no. 1, pp. 205–208, 1996. [Online]. Available: <https://doi.org/10.1145/234313.234400>
- [8] C. MacNamee and D. Heffernan, "Emerging on-ship debugging techniques for real-time embedded systems," *Computing & Control Engineering Journal*, vol. 11, pp. 295–303, 2000.
- [9] K. Whitehouse, G. Tolle, J. Taneja, C. Sharp, S. Kim, J. Jeong, J. Hui, P. Dutta, and D. E. Culler, "Marionette: using RPC for interactive development and debugging of wireless embedded networks," in *Proceedings of the Fifth International Conference on Information Processing in Sensor Networks, IPSN 2006, Nashville, Tennessee, USA, April 19-21, 2006*, J. A. Stankovic, P. B. Gibbons, S. B. Wicker, and J. A. Paradiso, Eds. ACM, 2006, pp. 416–423. [Online]. Available: <https://doi.org/10.1145/1127777.1127840>
- [10] P. L. Cueva, A. Bertaux, A. Termier, J. Méhaut, and M. Santana, "Debugging embedded multimedia application traces through periodic pattern mining," in *Proceedings of the 12th International Conference on Embedded Software, EMSOFT 2012, part of the Eighth Embedded Systems Week, ESWeek 2012, Tampere, Finland, October 7-12, 2012*, A. Jerraya, L. P. Carloni, F. Maraninchi, and J. Regehr, Eds. ACM, 2012, pp. 13–22. [Online]. Available: <https://doi.org/10.1145/2380356.2380366>
- [11] B. Hailpern and P. Santhanam, "Software debugging, testing, and verification," *IBM Syst. J.*, vol. 41, no. 1, p. 4–12, Jan. 2002. [Online]. Available: <https://doi.org/10.1147/sj.411.0004>
- [12] A. Murali, H. Kakarla, and G. Anitha Priyadarshini, "Improved design debugging architecture using low power serial communication protocols for signal processing applications," *International Journal of Speech Technology*, vol. 24, 06 2021.
- [13] F. Samie, L. Bauer, and J. Henkel, "Iot technologies for embedded computing: a survey," in *Proceedings of the Eleventh IEEE/ACM/FIP International Conference on Hardware/Software Codesign and System Synthesis, CODES 2016, Pittsburgh, Pennsylvania, USA, October 1-7, 2016*. ACM, 2016, pp. 8:1–8:10. [Online]. Available: <https://doi.org/10.1145/2968456.2974004>
- [14] M. Yue and Y. Sun, "Marine data collection based on embedded system with wired and wireless transmission," Master's thesis, Universitetet i Agder/University of Agder, 2013.
- [15] R. Friedman, A. Kogan, and Y. Krivolapov, "On power and throughput tradeoffs of wifi and bluetooth in smartphones," in *INFOCOM 2011. 30th IEEE International Conference on Computer Communications, Joint Conference of the IEEE Computer and Communications Societies, 10-15 April 2011, Shanghai, China*. IEEE, 2011, pp. 900–908. [Online]. Available: <https://doi.org/10.1109/INFCOM.2011.5935315>
- [16] A. Potsch, A. Berger, and A. Springer, "Efficient analysis of power consumption behaviour of embedded wireless iot systems," in *IEEE International Instrumentation and Measurement Technology Conference, I2MTC 2017, Torino, Italy, May 22-25, 2017*. IEEE, 2017, pp. 1–6. [Online]. Available: <https://doi.org/10.1109/I2MTC.2017.7969658>
- [17] R. Skowrya, S. Bahargam, and A. Bestavros, "Software-defined IDS for securing embedded mobile devices," in *IEEE High Performance Extreme Computing Conference, HPEC 2013, Waltham, MA, USA, September 10-12, 2013*. IEEE, 2013, pp. 1–7. [Online]. Available: <https://doi.org/10.1109/HPEC.2013.6670325>
- [18] Y. Hwang, S. Ku, C. Jung, and K. Chung, "Predictive power aware management for embedded mobile devices," in *Proceedings of the 13th Asia South Pacific Design Automation Conference, ASP-DAC 2008, Seoul, Korea, January 21-24, 2008*, C. Kyung, K. Choi, and S. Ha, Eds. IEEE, 2008, pp. 36–41. [Online]. Available: <https://doi.org/10.1109/ASPDAC.2008.4483976>
- [19] A. Ukil, J. Sen, and S. Koilakonda, "Embedded security for internet of things," in *2011 2nd National Conference on Emerging Trends and Applications in Computer Science*, 2011, pp. 1–6.
- [20] J. Brakensiek, A. Dröge, M. Botteck, H. Härtig, and A. Lackorzynski, "Virtualization as an enabler for security in mobile devices," in *Proceedings of the 1st Workshop on Isolation and Integration in Embedded Systems*, ser. IIES '08. New York, NY, USA: Association for Computing Machinery, 2008, p. 17–22. [Online]. Available: <https://doi.org/10.1145/1435458.1435462>
- [21] D. Drew, J. L. Newcomb, W. McGrath, F. Maksimovic, D. Mellis, and B. Hartmann, "The toastboard: Ubiquitous instrumentation and automated checking of breadboarded circuits," in *Proceedings of the 29th Annual Symposium on User Interface Software and Technology, UIST 2016, Tokyo, Japan, October 16-19, 2016*, J. Rekimoto, T. Igarashi, J. O. Wobbrock, and D. Avrahami, Eds. ACM, 2016, pp. 677–686. [Online]. Available: <https://doi.org/10.1145/2984511.2984566>
- [22] T. Booth, S. Stumpf, J. Bird, and S. Jones, "Crossed wires: Investigating the problems of end-user developers in a physical computing task," in *Proceedings of the 2016 CHI Conference on Human Factors in Computing Systems, San Jose, CA, USA, May 7-12, 2016*, J. Kaye, A. Druin, C. Lampe, D. Morris, and J. P. Hourcade, Eds. ACM, 2016, pp. 3485–3497. [Online]. Available: <https://doi.org/10.1145/2858036.2858533>
- [23] W. McGrath, J. Warner, M. Karchemsky, A. Head, D. Drew, and B. Hartmann, "Wifrost: Bridging the information gap for debugging of networked embedded systems," in *The 31st Annual ACM Symposium on User Interface Software and Technology, UIST 2018, Berlin, Germany, October 14-17, 2018*, P. Baudisch, A. Schmidt, and A. Wilson, Eds. ACM, 2018, pp. 447–455. [Online]. Available: <https://doi.org/10.1145/3242587.3242668>
- [24] R. Fonseca, P. Dutta, P. Levis, and I. Stoica, "Quanto: Tracking energy in networked embedded systems," in *8th USENIX Symposium on Operating Systems Design and Implementation, OSDI 2008, December 8-10, 2008, San Diego, California, USA, Proceedings*, R. Draves and R. van Renesse, Eds. USENIX Association, 2008, pp. 323–338. [Online]. Available: http://www.usenix.org/events/osdi08/tech/full_papers/fonseca/fonseca.pdf
- [25] R. L. Baskerville and J. Pries-Heje, "Short cycle time systems development," *Inf. Syst. J.*, vol. 14, no. 3, pp. 237–264, 2004. [Online]. Available: <https://doi.org/10.1111/j.1365-2575.2004.00171.x>
- [26] R. Hyde, "The fallacy of premature optimization," *Ubiquity*, vol. 2006, no. June, p. 4:2, 2006. [Online]. Available: <https://doi.org/10.1145/1147991.1147993>
- [27] P. S. Dodd and C. V. Ravishankar, "Monitoring and debugging distributed real-time programs," *Softw. Pract. Exp.*, vol. 22, no. 10, pp. 863–877, 1992. [Online]. Available: <https://doi.org/10.1002/spe.4380221005>
- [28] D. Spinellis, "Modern debugging: the art of finding a needle in a haystack," *Commun. ACM*, vol. 61, no. 11, pp. 124–134, 2018. [Online]. Available: <https://doi.org/10.1145/3186278>
- [29] F. Qian, Z. Wang, Y. Gao, J. Huang, A. Gerber, Z. M. Mao, S. Sen, and O. Spatscheck, "Periodic transfers in mobile applications:

network-wide origin, impact, and optimization,” in *Proceedings of the 21st World Wide Web Conference 2012, WWW 2012, Lyon, France, April 16-20, 2012*, A. Mille, F. Gandon, J. Misselis, M. Rabinovich, and S. Staab, Eds. ACM, 2012, pp. 51–60. [Online]. Available: <https://doi.org/10.1145/2187836.2187844>

- [30] L. Seno, S. Vitturi, and F. Tramarin, “Experimental evaluation of the service time for industrial hybrid (wired/wireless) networks under non-ideal environmental conditions,” in *IEEE 16th Conference on Emerging Technologies & Factory Automation, ETFA 2011, Toulouse, France, September 5-9, 2011*, Z. Mammeri, Ed. IEEE, 2011, pp. 1–8. [Online]. Available: <https://doi.org/10.1109/ETFA.2011.6059005>
- [31] B. Zhai, S. Pant, L. Nazhandali, S. Hanson, J. Olson, A. Reeves, M. Minuth, R. Helfand, T. M. Austin, D. Sylvester, and D. T. Blaauw, “Energy-efficient subthreshold processor design,” *IEEE Trans. Very Large Scale Integr. Syst.*, vol. 17, no. 8, pp. 1127–1137, 2009. [Online]. Available: <https://doi.org/10.1109/TVLSI.2008.2007564>
- [32] S. Heß, “Slotbaer / carrera digital 124/132 / cu daten-protokoll (update 2019),” <http://slotbaer.de/carrera-digital-124-132/9-cu-daten-protokoll.html>, 2019, accessed: 2021-05-18.