

L1-AWARE MULTILINGUAL MISPRONUNCIATION DETECTION FRAMEWORK

Yassine El Kheir, Shammur Absar Chowdhury, Ahmed Ali

Qatar Computing Research Institute, HBKU, Doha, Qatar

ABSTRACT

The phonological discrepancies between a speaker’s native (L1) and the non-native language (L2) serves as a major factor for mispronunciation. This paper introduces a novel multilingual MDD architecture, **L1-MultiMDD**, enriched with L1-aware speech representation. An end-to-end speech encoder is trained on the input signal and its corresponding reference phoneme sequence. First, an attention mechanism is deployed to align the input audio with the reference phoneme sequence. Afterwards, the L1-L2-speech embedding are extracted from an auxiliary model, pretrained in a multi-task setup identifying L1 and L2 language, and are infused with the primary network. Finally, the L1-MultiMDD is then optimized for a unified multilingual phoneme recognition task using connectionist temporal classification (CTC) loss for the target languages: English, Arabic, and Mandarin. Our experiments demonstrate the effectiveness of the proposed L1-MultiMDD framework on both seen – L2-ARTIC, LATIC, and AraVoiceL2v2; and unseen – EpaDB and Speechocean762 datasets. The consistent gains in PER, and false rejection rate (FRR) across all target languages confirm our approach’s robustness, efficacy, and generalizability.

Index Terms— Second language acquisition, Mispronunciation Detection Model, Non-native speech, End-to-end models, Multilingual, and Multi-task

1. INTRODUCTION

Mastering the second language (L2) pronunciation is crucial for effective communication and cultural integration. Mispronunciation detection and diagnosis (MDD) systems are integral parts of the Computer-aided Pronunciation Training (CAPT) system. Its effectiveness in aiding non-native speakers to overcome the challenges of learning a new language, and improve pronunciation skills [1].

Various approaches have been investigated to automate the MDD system. Methods extended from relying on pre-trained automatic speech recognition (ASR) systems to identify discrepancies between the aligned ASR output and the reference sequence, utilizing the log-posterior probability from the ASR to calculate different measures of goodness of pronunciation (GOP) scores [2, 3, 4] are explored. The deep learning techniques, either in an end-to-end approach

or by using a cascaded pipeline – trained with GOP features from a pre-trained ASR [5, 6], have also been utilized. The end-to-end models trained using the Connectionist Temporal Classification (CTC) loss have become increasingly popular due to their impressive performance in tasks related to detecting mispronunciations without the need for any alignment information [7, 8, 9, 10, 11, 12].

With recent advancement in multilingual speech research [13], there have been numerous efforts to model pronunciation assessment on utterance level scores in a multilingual context. Studies such as [14] explores the adaptation of pronunciation assessments from English (a stress-timed language) to Malay (a syllable-timed language), and [15] investigates the use of language-specific embeddings for diverse languages, while optimizing the entire network within a unified framework. However, limited research investigated MDD in multilingual scenarios.

In this paper, we introduce a novel L1-aware multilingual MDD – **L1-MultiMDD** – framework. The proposed framework exploits the contrasting and shared phonological representation of various L2 languages while considering the speaker’s L1 background. The framework is comprised of a primary MDD network and an auxiliary network designed to encode L1-L2 aware representation. The auxiliary network is instrumental in extracting and fusing L1-L2 language-specific information in the multilingual latent space, allowing the L1-MultiMDD to become more sensitive to the idiosyncrasies of each respective language.

The proposed L1-MultiMDD model supports 3 target languages – English, Arabic, and Mandarin, and is designed to accommodate speakers from any L1 background. The proposed model is superior in performance to monolingual models, with better generalization. Compared to prior research, our study is the first to investigate the role of multilinguality in MDD utilizing speakers’ L1 background. This integration of L1-L2 representation not only enriches the MDD performance but also opens up new avenues for *personalized and effective pronunciation assessment techniques*.

2. PROPOSED L1-MULTIMDD FRAMEWORK

Figure 1 shows an overview of our framework, designed to train an E2E-MDD model using multiple sources of information. The system is comprised of a primary MDD network

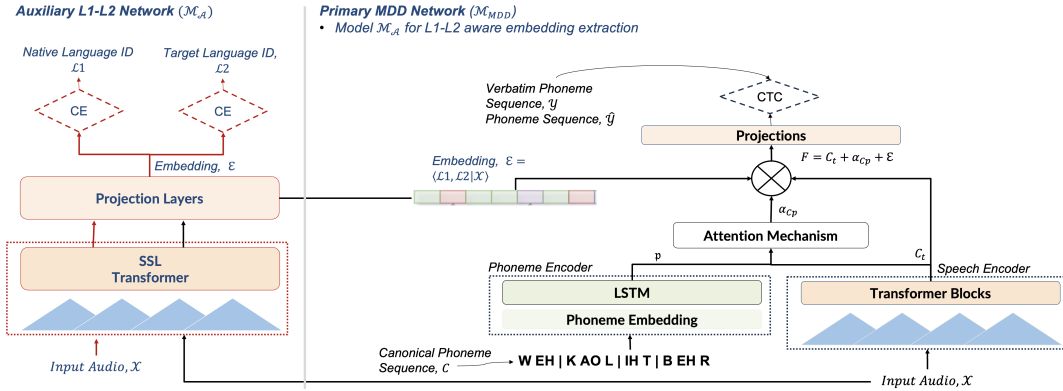

Fig. 1: Overview of proposed L1-MultiMDD framework.

Corpus	Target (L2)	Native (L1)	#Spks	Use (Unseen)	Split(trn/vld/tst)
L2-ARTIC [16]	English	Hindi, Korean, Mandarin, Spanish, and Arabic	24	trn/tst	12(2hrs)/6(0.8hrs)/6(0.8hrs)
LATIC [17]	Mandarin	Russian, Korean, French, and Arabic	4	trn/tst	2(2hrs)/1(0.8hrs)/1(1hr)
AraVoiceL2 [18] v2*	Arabic	Turkish, Benin, Nigerian, Ivory, Indonesian, Thailand, Malaysian, Bangladeshi, Madagascar, Chad, and Cameroon	32	trn/tst	19(9hrs)/2(0.8hrs)/11(5.15hrs)
EpaDB [19]	English	Spanish	50	tst (Domain)	1263 #utt
Speechocean762 [?]	English	Mandarin	250	tst (C and A)	2500 #utt

Table 1: Data description for L1-MultiMDD model. #Spks: Number of speakers. #utt: Number of utterances. C: Children and A: Adult data.

and an auxiliary network.

The *primary MDD* model adopts the phoneme recognition task as the main objective, and enforces that the network is able to detect the verbatim phoneme sequence of the speaker’s utterance. The primary MDD network takes raw input speech, along with canonical phonemes of the reference text. The *auxiliary network* encapsulates the speaker-invariant representation by classifying L1 and L2 languages of the speaker in a supervised manner. The network is text-independent and takes raw speech as input to the network.

2.1. Primary MDD Network

Given the input raw signal $\mathcal{X} = (x_1, x_2, \dots, x_n)$, of n sample length, we first extracted contextualized acoustic representations C_t (of dimension $D : 1024$) from the *Speech Encoder*. The speech encoder uses a CNN-based encoder network to encode the raw audio sample and a transformer-based context network to build context representations C_t over the entire latent speech representation Z . The weight of the speech encoder is initiated from the pre-trained network trained in self-supervised manner with a weighted sum of contrastive loss and code-book diversity loss. Simultaneously, we extract the canonical phoneme embedding p from the *Phoneme Encoder* which is composed of an embedding layer ($D : 82$)¹ followed by a BiLSTM layer ($D : 512$) to give p ($D : 1024$).

The phoneme embedding p and the contextualized acoustic representations C_t are then passed to an attention layer that takes p as key and query, and C_t as value. The embeddings C_t and α_{cp} ($D : 1024$) are then concatenated with the L1-L2-

aware embedding ε ($D : 1024$) from the auxiliary network to make the L1-L2-aware latent representation, $F = C_t + \alpha_{cp} + \varepsilon$ ($D : 3072$). The F is passed through a feed-forward projection layer and then to a phoneme output head (PR). The output head is trained using the CTC loss (\mathcal{L}_{PR}), calculated by comparing the predicted L2 speech phoneme sequence $\hat{\mathcal{Y}} = (\hat{y}_1, \hat{y}_2, \dots, \hat{y}_m)$ with the human-labeled phoneme sequences $\mathcal{Y} = (y_1, y_2, \dots, y_l)$.

Multilingual Phoneme Set We construct a unified phoneme set combining all the phoneme units present in the three target languages. We prepared a list of phonemes \mathcal{P}_{S_l} that are present in the canonical and the verbatim phoneme sequences of the target languages, $l \in \{\text{English, Mandarin, Arabic}\}$. Hence the final list is $\mathcal{P}_S = \mathcal{P}_{S_E} \cup \mathcal{P}_{S_M} \cup \mathcal{P}_{S_A}$, including all the common phoneme symbols while preserving language-specific phonemes. We used \mathcal{P}_S ($D : 82$) in both input and output level for the MDD model. We obtain the phonemic annotations of reference and manually annotated transcriptions using ESpeak².

2.2. Auxiliary L1-L2 Network

The auxiliary network takes raw signal \mathcal{X} as input and passes it to a pre-trained SSL model, containing a CNN-based feature encoder and transformer encoders, to extract the contextualized acoustic features. These features are then passed through a projection layer to get L1-L2 aware **auxiliary embedding** ε , followed by task-dependent output head. The model \mathcal{M}_A is optimized for *Native* and *Target* language identification jointly using Cross-Entropy (CE) as loss functions.

¹For monolingual setups, we used the dimension of language-specific phoneme set

²<https://github.com/espeak-ng/espeak-ng>

One-hot representation of L1-L2 (⊙): We also examined the impact of incorporating L1-L2 information through one-hot encoding instead of auxiliary embedding. This implementation is straightforward and is most effective when all L1 background are known.

2.3. Parameter Learning Strategies

During parameter learning, both the networks, \mathcal{M}_{MDD} and \mathcal{M}_A are either jointly or sequentially optimized. For **Sequential** learning, the auxiliary \mathcal{M}_A network is first trained independently. We then freeze the auxiliary model and use it to extract L1-L2 aware embedding (ε) for the primary \mathcal{M}_{MDD} network training. For the **Joint** modeling, we initiate the \mathcal{M}_A using the pre-trained weights, we then update the weights of both the \mathcal{M}_{MDD} and \mathcal{M}_A models during training. ε^* represents the final embedding from \mathcal{M}_A , the jointly learned with \mathcal{M}_{MDD} model.

3. EXPERIMENTAL SETUP

3.1. Datasets

To train the multilingual model, we combined the monolingual MDD dataset, presented in Table 1, and created multi-target MDD dataset. For the auxiliary \mathcal{M}_A model, we deliberately avoided using any additional L2 data and used the same dataset as the primary MDD model, Nonetheless, our L1-MultiMDD model remains flexible, readily accommodating to any external data or pre-trained models.

3.2. Pre-trained Speech Encoder

The wav2vec2-large³ [20] model is a pre-trained wav2vec2.0 It follows the same architecture as the wav2vec2.0 model. The encoder network consists of blocks of temporal convolution layers with 512 channels, and the convolutions in each block have strides and kernel sizes that compress about 25ms of 16kHz audio every 20ms. The context network consists of 24 blocks with model dimension 1024, inner dimension 4096, and 16 attention heads.

3.3. Model Training

The models are optimized using Adam optimiser for 100 epochs with early stopping criterion. The initial learning rate is set to 1×10^{-4} , with a batch size of 32. For all setups, the features extraction layers remain frozen and only transformer layers are finetuned. The primary loss criterion is CTC loss denoted as \mathcal{L}_{PR} with a weight $\alpha = 1$. However, in the case of L1-Multi: $\langle p, \varepsilon^* \rangle$ (Joint) setup, a combination loss is utilised consisting of \mathcal{L}_{PR} with weight $\alpha = 0.8$ and CE losses for classification of L1 and L2 denoted as $loss_{L1}$,

$loss_{L2}$ with a weight $1 - \alpha = 0.2$. The total loss is then defined then as $\mathcal{L}_{total} = \alpha \times \mathcal{L}_{PR} + (1 - \alpha) \times (loss_{L1} + loss_{L2})$. Using the same configurations, we conducted fine-tuning on the auxiliary L1-L2 Network \mathcal{M}_A , which involved optimizing it with a weighted loss. This weighted loss was defined as $(0.5 \times loss_{L1} + 0.5 \times loss_{L2})$. \mathcal{M}_A achieves L1 classification accuracy of 60%, and L2 classification accuracy of 99.9% evaluated on common testset described in Section 3.1.

3.4. Evaluation

We assess the model’s ability to predict L2 phoneme sequences by reporting phoneme error rate. Additionally, we adopt the proposed hierarchical evaluation structure outlined in [21] to report F1 score, which takes into account the predicted, reference and annotated phoneme sequences, and it’s computed using precision indicating the number of modeled mispronunciations over the number of mispronunciations returned by the rule set, and the recall representing the number of modeled mispronunciations over the number of mispronunciations found in the evaluation set. Furthermore, we reported false rejection rate (FRR), which signifies the rate of phonemes recognized as mispronunciations when the actual pronunciations are correct. FRR measure the model’s ability to distinguish between close phoneme among different languages in our multilingual setup. Hence FRR and PER are our primary evaluation metrics.

4. RESULTS AND DISCUSSION

Table 2 presents the efficacy of our L1-MultiMDD model over both monolingual and multilingual systems with phoneme embedding.

Monolingual vs Multilingual MDD systems Our results indicate that monolingual with (or without) phoneme embedding (p) outperform multilingual models lacking target language (L2) information. The multilingual model struggles to distinguish between the close sound units without any L2 knowledge. This highlights the importance of providing L2 information to the network, this observation is also supported in Multi: $\langle p, \odot(L2) \rangle$ results where addition of one-hot encoded L2 information in the multilingual system drastically improve PER and FFR. Showing $\Rightarrow Multi:(p, \odot(L2)) \gg^4 Mono:(*)$

Efficacy of L1 and L2 information induction When comparing between the Multi: $\langle p, \odot(L2) \rangle$ model with its L1-aware counterpart L1-Multi: $\langle p, \odot(L1, L2) \rangle$, we observed a significant improvement in all three test datasets. This trend remains consistent when comparing Multi: $\langle p, \odot(L2) \rangle$ with L1-aware model using auxiliary network (L1-Multi: $\langle p, \varepsilon \rangle$). These results highlights the significance of incorporating L1-awareness into MDD models, leading to conclusion $\Rightarrow L1-Multi:(*) \gg \{Multi:(*), Mono:(*)\}$

³<https://huggingface.co/facebook/wav2vec2-large-robust>

⁴ \gg represent the strenght of the architecture.

Dataset	F1 \uparrow	FRR \downarrow	PER \downarrow
Monolingual vs Multilingual			
Mono			
L2-Artic	56.42%	6.30%	14.13
LATIC	56.13%	7.25%	9.27
AraVoiceL2 v2	76.91%	3.95%	7.39
Mono: $\langle p \rangle$			
L2-Artic	<u>57.37%</u>	5.61%	13.46
LATIC	73.91%	3.11%	4.61
AraVoiceL2v2	<u>77.73%</u>	2.93%	7.03
Multi			
L2-Artic	54.40%	5.76%	13.99
LATIC	54.40%	7.82%	10.16
AraVoiceL2v2	75.86%	3.74%	7.42
Multi: $\langle p \rangle$			
L2-Artic	55.81%	5.46%	13.70
LATIC	66.84%	4.25%	6.36
AraVoiceL2v2	71.76%	4.62%	10.96
Multi: $\langle p, \mathbb{O}(L_2) \rangle$			
L2-Artic	55.98%	<u>5.10%</u>	<u>13.29</u>
LATIC	<u>75.65%</u>	<u>2.54%</u>	<u>4.11</u>
AraVoiceL2v2	76.88%	<u>2.46%</u>	<u>6.86</u>
Proposed L1-aware Multi: One-hot Embed. (topline)			
L1-Multi: $\langle p, \mathbb{O}(L_1) \rangle$			
L2-Artic	57.14%	4.56%	12.66
LATIC	75.96%	2.32%	3.92
AraVoiceL2v2	76.28%	2.31%	6.80
L1-Multi: $\langle p, \mathbb{O}(L_1, L_2) \rangle$			
L2-Artic	57.12%	4.26%	12.52
LATIC	75.77%	2.27%	3.93
AraVoiceL2v2	78.00%	2.03%	6.42
Proposed L1-aware Multi: Aux Embed.			
L1-Multi: $\langle p, \varepsilon \rangle$ (Sequential)			
L2-Artic	57.40%	4.60%	12.55
LATIC	74.82%	2.45%	4.19
AraVoiceL2v2	78.42%	2.25%	6.13
L1-Multi: $\langle p, \varepsilon^* \rangle$ (Joint)			
L2-Artic	56.87%	4.87%	12.92
LATIC	75.34%	2.23%	4.38
AraVoiceL2v2	76.44%	2.27%	6.35

Table 2: Results for different experimental settings. $\langle p \rangle$ represent phoneme embedding, $\langle \mathbb{O}(L_*) \rangle$: indicate one-hot L_* . Auxiliary (Aux.) network training sequentially ($\langle \varepsilon \rangle$) or jointly ($\langle \varepsilon^* \rangle$). topline: best-case scenario knowing all possible L1s. Green rows highlight our proposed frameworks; bold values are best for each dataset/metric.

One-hot vs Auxiliary embedding We investigate the effects of incorporating L1-L2 information into MDD model through two methods: one-hot embedding (\mathbb{O}) and embedding (ε) extraction from the auxiliary model. Our findings indicate that \mathbb{O} performs slightly better than Auxiliary embedding, ε in terms of performance. However, using \mathbb{O} comes with a cost of limiting L1-MultiMDD model to few L1 backgrounds. Hence, unless the focused learner has specific L1 background, auxiliary embedding shows superior performance.

Unseen dataset	SpeechOcean762		EpaDB	
	FRR \downarrow	PER \downarrow	FRR \downarrow	PER \downarrow
Mono: $\langle p \rangle$ [L2-ARTIC]	21.30%	28.9	13.32%	27.56
Multi: $\langle p, \mathbb{O}(L_1) \rangle$	18.65%	22.95	13.01%	26.35
L1-Multi: $\langle p, \mathbb{O}(L_1, L_2) \rangle$	15.41%	19.6	10.12%	23.82
L1-Multi: $\langle p, \varepsilon \rangle$	15.56%	19.62	10.93%	24.82
L1-Multi: $\langle p, \varepsilon^* \rangle$	19.27%	23.82%	14.54%	27.82%
Upper Bound Mono	–	9.93% ⁺ [22]	–	17.67%*

Table 3: Reported FRR and PER for unseen dataset. Mono model: trained using L2-ARTIC data set. #⁺: The model is jointly learned for MDD and pronunciation assessment in a multi-task setting with additional L1 data. #*: Finetuned wav2vec2-large model on EpaDB.

Learning L1-L2 jointly vs sequentially As for the training strategy of the auxiliary network, our results shows sequential learning to be more effective than joint training in terms of performance when both trained on a constrained setup.

Generalization of the Framework Table 3 shows FRR and PER results for two unseen datasets: SpeechOcean762 and EpaDB, both featuring English as L2. EpaDB has an unseen L1 of Argentinian Spanish, while SpeechOcean762 has L1 Mandarin and includes both adult and child speakers—data types our multilingual MDD models haven’t previously encountered. Despite these challenges, we observed that L1-MultiMDD models significantly outperform monolingual English model trained with L2-ARTIC, indication the generalization potential of the proposed network.

5. CONCLUSION

In this study, we propose a novel L1-aware multilingual MDD, L1-MultiMDD, model that (a) leverage an auxiliary network to capture speakers L1 background jointly with the L2 language information; (b) fuse the extracted L1-L2 aware embedding to the MDD model; and (c) learn to capture multilingual latent representation while being sensitive to uniqueness of each language. Our proposed L1-MultiMDD demonstrate efficacy over its counterpart MultiMDD, and outperforms all variation of monolingual models, trained separately on the in-domain data. The L1-MultiMDD shows better generalization capability when compared to monolingual model trained on unseen data.

6. REFERENCES

- [1] Ambra Neri, Ornella Mich, Matteo Gerosa, and Diego Giuliani, “The effectiveness of computer assisted pronunciation training for foreign language learning by children,” *Computer Assisted Language Learning*, 2008.
- [2] Silke M Witt and Steve J Young, “Phone-level pronunciation scoring and assessment for interactive language learning,” *Speech communication*, 2000.
- [3] Jiatong Shi, Nan Huo, and Qin Jin, “Context-aware goodness of pronunciation for computer-assisted pronunciation training,” *arXiv preprint arXiv:2008.08647*, 2020.
- [4] Sweekar Sudhakara, Manoj Kumar Ramanathi, Chiranjeevi Yarra, and Prasanta Kumar Ghosh, “An improved goodness of pronunciation (GOP) measure for pronunciation evaluation with DNN-HMM system considering HMM transition probabilities,” in *INTERSPEECH*, 2019.
- [5] Yuan Gong, Ziyi Chen, Iek-Heng Chu, Peng Chang, and James Glass, “Transformer-based multi-aspect multi-granularity non-native english speaker pronunciation assessment,” in *ICASSP*, 2022.
- [6] Fu-An Chao, Tien-Hong Lo, Tzu-I Wu, Yao-Ting Sung, and Berlin Chen, “3M: An effective multi-view, multi-granularity, and multi-aspect modeling approach to english pronunciation assessment,” in *APSIPA ASC*, 2022.
- [7] Wai-Kim Leung, Xunying Liu, and Helen Meng, “CNN-RNN-CTC based end-to-end mispronunciation detection and diagnosis,” in *ICASSP*, 2019.
- [8] Yiqing Feng, Guanyu Fu, Qingcai Chen, and Kai Chen, “SED-MDD: Towards sentence dependent end-to-end mispronunciation detection and diagnosis,” in *ICASSP*, 2020.
- [9] Minglin Wu, Kun Li, Wai-Kim Leung, and Helen Meng, “Transformer based end-to-end mispronunciation detection and diagnosis,” in *Interspeech*, 2021.
- [10] Kaiqi Fu, Jones Lin, Dengfeng Ke, Yanlu Xie, Jinsong Zhang, and Binghuai Lin, “A full text-dependent end to end mispronunciation detection and diagnosis with easy data augmentation techniques,” *arXiv preprint arXiv:2104.08428*, 2021.
- [11] Xiaoshuo Xu, Yueteng Kang, Songjun Cao, Binghuai Lin, and Long Ma, “Explore Wav2vec 2.0 for mispronunciation detection,” in *Interspeech*, 2021.
- [12] Yassine El Kheir, Shammur Absar Chowdhury, and Ahmed Ali, “Multi-view multi-task representation learning for mispronunciation detection,” *arXiv preprint arXiv:2306.01845*, 2023.
- [13] Vineel Pratap, Andros Tjandra, Bowen Shi, Paden Tomasello, Arun Babu, Sayani Kundu, Ali Elkahky, Zhaoheng Ni, Apoorv Vyas, Maryam Fazel-Zarandi, et al., “Scaling speech technology to 1,000+ languages,” *arXiv preprint arXiv:2305.13516*, 2023.
- [14] Huayun Zhang, Ke Shi, and Nancy F Chen, “Multi-lingual speech evaluation: English, Malay and Tamil,” *arXiv preprint arXiv:2107.03675*, 2021.
- [15] Binghuai Lin and Liyuan Wang, “Multi-lingual pronunciation assessment with unified phoneme set and language-specific embeddings,” in *ICASSP 2023*, 2023.
- [16] Guanlong Zhao, Sinem Sonsaat, Alif Silpachai, Ivana Lucic, Evgeny Chukharev-Hudilainen, John Levis, and Ricardo Gutierrez-Osuna, “L2-ARCTIC: A non-native English speech corpus,” in *Interspeech*, 2018.
- [17] XIAO ZHANG, “LATIC: A non-native pre-labelled mandarin chinese validation corpus for automatic speech scoring and evaluation task,” 2021.
- [18] Yassine El Kheir, Shammur Absar Chowdhury, Hamdy Mubarak, Shazia Afzal, and Ahmed Ali, “Speechblender: Speech augmentation framework for mispronunciation data generation,” 2023.
- [19] Jazmín Vidal, Luciana Ferrer, and Leonardo Brambilla, “EpaDB: A database for development of pronunciation assessment systems,” in *INTERSPEECH*, 2019.
- [20] Alexis Conneau, Alexei Baevski, Ronan Collobert, Abdelrahman Mohamed, and Michael Auli, “Unsupervised cross-lingual representation learning for speech recognition,” 2020.
- [21] Xiaojun Qian, Helen Meng, and Frank Soong, “Capturing L2 segmental mispronunciations with joint-sequence models in computer-aided pronunciation training (CAPT),” in *International Symposium on Chinese Spoken Language Processing*, 2010.
- [22] Hyungshin Ryu, Sunhee Kim, and Minhwa Chung, “A Joint Model for Pronunciation Assessment and Mispronunciation Detection and Diagnosis with Multi-task Learning,” in *INTERSPEECH*, 2023.