

# Test Case Generation and Test Oracle Support for Testing CPSs using Hybrid Models

Zahra Sadri-Moshkenani, Justin Bradley, Gregg Rothermel

**Abstract**—Cyber-Physical Systems (CPSs) play a central role in the behavior of a wide range of autonomous physical systems such as medical devices, autonomous vehicles, and smart homes – many of which are safety-critical. CPSs are often specified iteratively as a sequence of models at different levels that can be tested via simulation systems at early stages of their development cycle. One such model is a hybrid automaton; these are used frequently for CPS applications and have the advantage of encapsulating both continuous and discrete CPS behaviors. When testing CPSs, engineers can take advantage of these models to generate test cases that target both types of these behaviors. Moreover, since these models are constructed early in the development process for CPSs, they allow test cases to be generated early in that process for those CPSs – even before simulation models of the CPSs have been designed. One challenge when testing CPSs is that these systems may operate differently even under an identically applied test scenario. In such cases, we cannot employ test oracles that use predetermined deterministic behaviors; instead, test oracles should consider sets of desired behaviors in order to determine whether the CPS has behaved appropriately. In this paper we present a test case generation technique, HYTEST, that generates test cases based on hybrid models, accompanied by appropriate test oracles, for use in testing CPSs early in their development cycle. To evaluate the effectiveness and efficiency of HYTEST, we conducted an empirical study in which we applied the technique to several CPSs and measured its ability to detect faults in those CPSs and the amount of time required to perform the testing process. The results of the study show that HYTEST was able to detect faults more effectively and efficiently than the baseline techniques we compare it to.

**Index Terms**—Cyber-Physical Systems, Embedded-Control Systems, Test Case Generation, Hybrid Models, Test Oracles.

## I. INTRODUCTION

CYBER-PHYSICAL Systems (CPSs) involve a set of integrated software components and hardware devices that communicate with one another and interact with the environment through sensors and actuators, typically in a feedback loop [1]. They use this feedback to adapt their behavior to the environment and achieve their goals. CPSs are used in a wide range of applications including smart homes, medical devices, and autonomous vehicles – many of which are safety-critical.

Zahra Sadri-Moshkenani and Gregg Rothermel are with the Department of Computer Science, North Carolina State University. E-mail: {zsadrim,gerother}@ncsu.edu. Justin Bradley is with the School of Computer Science and Engineering, University of Nebraska-Lincoln, justin.bradley@unl.edu.

This work has been submitted to the IEEE for possible publication. Copyright may be transferred without notice, after which this version may no longer be accessible.

CPSs, like software and hardware systems generally, must operate according to specific functional requirements while also satisfying non-functional requirements. Engineers use various verification and validation processes such as reviews, testing, and formal methods to detect problems in such systems and to determine whether such systems meet their requirements [2]. In this work we focus on testing techniques.

With CPSs, delaying testing activities until the final system is ready to operate in a real environment greatly increases the likelihood that serious faults will occur in that final system. Delaying testing also increases the possibility that such faults will be expensive, particularly in safety-critical systems, due to the risks to hardware components, equipment, and people that are involved in the final system. Early testing is imperative.

CPSs are often first specified iteratively as a sequence of model abstractions at different levels that can be tested using simulation models [3]. Three common levels of abstraction (from most to least abstract) are: (1) Model-in-the-Loop (MiL), where the entire CPS is represented by a model; (2) Software-in-the-Loop (SiL), where the model of the controller is replaced with its code, but other components including hardware components continue to be represented by models, and (3) Hardware-in-the-Loop (HiL), where the controller software is installed on the final platform and the other components, including hardware components, are fully realized. Testing CPS models at higher levels of abstraction before continuing on to develop the next level of models can result in earlier detection of faults and prevent those faults from propagating to the next levels, where they can be more expensive.

Many CPSs can be mathematically modeled by hybrid models [4]. One such model is a *hybrid automaton*, which is a formal model for a “hybrid system” – a system with mixed discrete-continuous behaviour [5]. Alur [6] defines “hybrid systems” as “systems characterized by the interaction between discrete (digital) and continuous (physical) components.” A hybrid model of a system can be designed using the dynamic equations for the system as soon as these equations are known. Alur [6] notes that hybrid automata “are a central model for many CPS applications, from avionics to biomedical devices”. For such CPSs, using a hybrid model as a basis for testing requires no extra modeling effort beyond that which is already required in the construction of such systems. (For additional information on hybrid models see Section II-A).

When test cases are generated from hybrid models, they can target both continuous and discrete CPS behaviors [5], [7]. Further, it is difficult to predict all the conditions a CPS will encounter and test it under those conditions, due to the complicated interactions between the cyber and physical

environments of a CPS [8]. The effect of those conditions, however — whether external and environmental or internal — is reflected in the values of the CPS’s states, which are all captured in the hybrid model as invariants and guard conditions (this is also discussed further in Section II-A.)

Since hybrid models are designed at early stages of CPS development, i.e., at the system dynamics recognition stage, they allow test case generation to begin early in the design process of CPSs — even before the simulation model of the CPS is designed.

Several techniques for generating test cases for CPSs have been proposed; our earlier survey of testing approaches for CPSs [9] discusses these. Several authors have proposed techniques that use simulation models (e.g., [3], [10]–[22]). These techniques operate under the assumption that the simulation models have been designed correctly and that their correctness has been validated. In this case the simulation models can be used as ground truth models for generating test cases at the MiL level, and those test cases can then be used to test the CPS at the SiL or HiL levels. In this case, however, testing *at the MiL level* using the generated test cases does not occur.

There are other techniques for generating test cases for CPSs that generate test cases based on either the continuous or the discrete behavior of the CPS, but not both. Badban et al. [23] present a technique that targets the continuous behaviors of systems while Matinnejad et al. [3] present a technique that generates test cases for continuous controllers. These two techniques focus on continuous behaviors and do not target discrete behaviors when generating test cases. Bender et al. [24] propose a technique that generates test cases using discrete behaviors of the system and ignores its continuous behaviors. While such a technique may be fine in cases where only one or the other type of behavior is present, where both types are present the technique could miss important faults.

Several test case generation techniques for CPSs generate redundant test cases (e.g., [3], [8], [11], [12], [15], [17]–[22], [25]–[34]); these incur unneeded costs.

A large number of test case generation techniques (e.g., [35]–[38]) are non-CPS specific, are not guaranteed to work on CPSs, and have not been studied in CPS contexts. More work — including substantial empirical work, is required to determine whether these techniques might be applicable to CPSs or not. For additional information see our survey [9].

Some test case generation techniques operate under the assumption that CPSs have a finite set of expected behaviors, and generate test cases based on this assumption. For example, Humeniuk et al. [39] expect the system under test to remain in each state for a predetermined amount of time. Such assumptions, however, do not typically hold in practice, where unexpected conditions can cause a CPS to exhibit unexpected behavior. Some techniques (e.g., [21], [40]–[42]) focus on generating test cases that are fault-revealing or falsifying, without attempting to assess whether the CPS functions as expected. When these techniques do not find failures, we still cannot know whether the CPS behaves in accordance with its requirements. Finally, several techniques generate test cases for specific types of CPSs [43]–[50]. As an example, Moghadam et al. [43] propose a technique that generates

critical test roads on which to test an autonomous-driving car.

When testing any software system it is important to have a “test oracle” — a method or device by which we can determine whether test cases reveal faulty output or behavior. Typical test oracles consider actual output or behaviors elicited by test cases and compare them to expected outputs or behaviors. Where CPSs are concerned, it can be difficult or impossible to codify what the expected output or behavior of the system is. CPSs are reactive systems that attempt to keep an ongoing interaction going in an acceptable way within an environment, rather than producing a final result upon termination [51]. The standard correctness requirement for such systems is that all executions must be allowed based on the system requirements and specifications [52], so a traditional test oracle that checks the correctness of the final results against a ground truth may issue a “failure” when the test results are not equal to the ground truth, whereas the CPS may have operated in an acceptable way and reached its goal. For example, the goal of a robot could be to reach a predefined target while avoiding obstacles in the environment, and in such a case we do not necessarily expect the robot to follow a specific and predefined trajectory. The expected behavior is simply to reach the target while avoiding the obstacles, irrespective of path.

Several CPS testing techniques ([8], [14], [16], [18], [20], [25], [26], [28], [32]) rely on manual test oracles or provide test oracles that issue verdicts by comparing test results against ground truths, which are usually expected outputs. For reactive CPSs such oracles are problematic.

In this article we present HYTEST, a new technique for generating test cases for CPSs based on *hybrid models*. HYTEST allows *pre-MiL level* test case generation, and the generated test cases can then be used to perform system testing of the simulation models of the CPS at the MiL and SiL levels or of the final product at the HiL level.<sup>1</sup> As HYTEST generates test cases, it also employs an algorithm that reduces the incidence of redundant test cases, based on the hybrid model, rendering testing more efficient. Finally, HYTEST provides a test oracle that uses the generated test cases to test the CPS as a reactive system. In other words, HYTEST’s test oracle checks whether the system operates correctly and in an acceptable manner, i.e., over an acceptable order of CPS states and transitions, to meet the goal or not.

We assume that the hybrid model of the CPS under test has been formally verified by test/control engineers (i.e., checked for reachability and other problems [53]) prior to using HYTEST — an assumption shared by many other existing techniques. However, in some situations in which the hybrid model is not designed correctly, HYTEST can detect this, display an error message, and end its execution.

This work provides the following contributions:

- A novel test case generation technique, HYTEST, that generates and selects test cases for CPSs based on hybrid models and effectively and efficiently targets the mixed continuous and discrete behaviors of CPSs at the MiL level.

<sup>1</sup>In this work, we focus primarily on the MiL level.

- A novel test oracle that can automatically recognize incorrect CPS behavior during simulation, using the states and transitions in the hybrid model, and issue an appropriate test verdict based on these.
- An empirical study examining the use of HYTEST on simulation models developed in Simulink [54] at the MiL level, that shows that HYTEST was able to reveal more faults in a sample of CPSs as efficiently (in a more complicated CPS) and more efficiently (in several less complicated CPSs) than a pair of baseline techniques. Our results show that overall HYTEST was able to reveal all the faults in the CPSs considered in a reasonable amount of time. Our results also show that our test oracle issued the correct test verdicts for all test cases, without any need for manual effort.

## II. BACKGROUND

### A. Models

Models can express the structure and behavior of systems through conceptual or mathematical representations [55]. Models are useful for describing, developing, and validating systems such as CPSs. A *formal model* is a model that expresses the properties of a system at some level of abstraction [56]. Formal models typically represent systems using certain formalisms (e.g., linear temporal logic [57]), and are created prior to the development and deployment of such systems [58]. A wide range of models have been utilized where software systems are concerned. Here we describe two types of models that are relevant to CPSs and that we use in this work.

1) *Hybrid Models*: A hybrid automaton is a formal model that is used to represent a dynamical system with discrete and continuous components [5]. A hybrid automaton is a labeled and directed graph (a finite state machine) that has the following components [5], [7]:

- $X$ : A finite set  $X = \{x_1, \dots, x_n\}$  of real-valued variables.
- $V$ : A finite set of vertices, or discrete modes, indicating a control mode/location. All of these modes are “acceptable” because they are known/expected in the CPS and show the possible modes that a CPS can have while it is functioning.
- $E$ : A set of directed arcs or edges between vertices. An edge  $e \in E$  is also called a control switch or transition.
- Flow condition: equations in the variables in  $X$  describing continuous evolution of the system. While the hybrid automaton is in control mode  $v \in V$ , the variables  $x_i$  change according to the flow condition.
- Invariant condition: A condition under which the hybrid model may reside in control mode  $v$ .
- Guard: An assignment of the variables in  $X$ . Each transition is associated with a guard. A transition is enabled when its assigned guard is true and its execution modifies the values of the variables according to the assignment.
- State: A state  $\sigma = (v, x)$  of the hybrid automaton consists of a mode  $v \in V$  and a continuous state  $x_n \in X$ . The state can change either by a discrete and instantaneous transition or over the passage of an interval of time

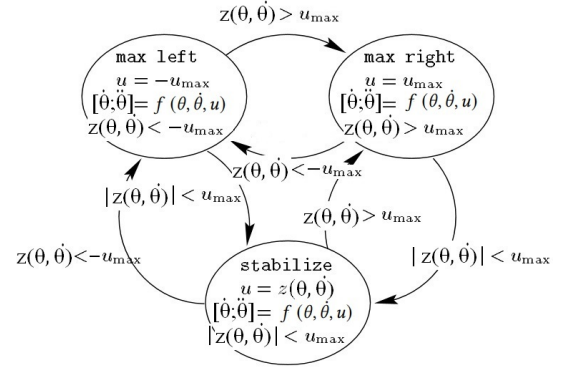

Fig. 1. Hybrid model for an inverted pendulum [59].

through the continuous flow. A discrete transition changes both the control mode and the real-valued variables, while the passage of an interval of time changes only the values of the variables in  $X$  according to the flow condition.

In a hybrid automaton model of a CPS, vertices model the discrete states, or modes, of the system while edges model its discrete dynamics or switches.

Such an automaton can be used to design a controller and to develop a CPS, via simulation models or an implementation.

Figure 1, taken (with small modifications) from [59], depicts a hybrid model for a CPS. (This model and the CPS to which it corresponds are described in Section II-C.) In Figure 1:

- $X = \{\theta, \dot{\theta}, u\}$
- $V = \{\text{“max left”}, \text{“max right”}, \text{“stabilize”}\}$
- $E = \{\text{“max left”} \rightarrow \text{“max right”}, \text{“max right”} \rightarrow \text{“max left”}, \text{“max left”} \rightarrow \text{“stabilize”}, \text{“max right”} \rightarrow \text{“stabilize”}, \text{“stabilize”} \rightarrow \text{“max left”}, \text{“stabilize”} \rightarrow \text{“max right”}\}$
- Flow conditions:  $[\dot{\theta}; \ddot{\theta}] = f(\theta, \dot{\theta}, u)$ ,  $u = z(\theta, \dot{\theta})$  in “stabilize”,  $u = -u_{max}$  in “max left”,  $u = u_{max}$  in “max right” (See [12] for more details).
- Invariant conditions:  $\{z(\theta, \dot{\theta}) < -u_{max}, z(\theta, \dot{\theta}) > u_{max}, |z(\theta, \dot{\theta})| < u_{max}\}$
- Guards:  $\{z(\theta, \dot{\theta}) < -u_{max}, z(\theta, \dot{\theta}) > u_{max}, |z(\theta, \dot{\theta})| < u_{max}\}$ .

2) *Simulation Models*: Simulation models typically form the basis of computer simulations [60]. Simulation models can be executed in a virtual environment to demonstrate the behavior of a system before that system has been implemented. Tests can be performed as simulations on simulation models [61].

### B. Model-Based Testing

*Model-based testing* is typically performed prior to system development and deployment allowing test engineers to examine whether a system’s model conforms to the system’s specifications. Model-based testing techniques typically generate test cases from structural or behavioral models of a system. [62]. Such *model-based test cases* are typically abstract, and require additional detail relevant to a system’s implementation to be added to them; this transforms them into *concrete test cases* that can be executed on an implemented system or its more detailed models. Model-based test cases are typically easier to maintain than code-based test cases, and they can be used to measure the *coverage* (of the model) achieved in testing.

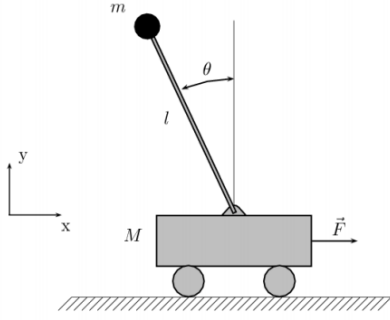

Fig. 2. Inverted Pendulum [63]

### C. Extended Example

To illustrate HYTEST in this article, we utilize the simple example presented in [9], [59], [63]. Figure 2 depicts a system that includes an inverted pendulum of length  $l$  and mass  $m$  mounted on a cart of mass  $M$ . A force,  $F$ , is applied to the cart and drags it forward or backward to balance the pendulum. To maintain stability (i.e., a balanced pendulum), a control input is computed and sent to the motors in the cart's wheels periodically based on feedback the sensors provide, i.e. information about the angle,  $\theta$ , and angular velocity,  $\dot{\theta}$ , of the pendulum.

A general template for a test case for the inverted pendulum system can be written as follows:

$$testcase_{i,j} = \left\{ F_i, \theta_i, \dot{\theta}_i, x_i, \dot{x}_i, \theta_j, \dot{\theta}_j, x_j, \dot{x}_j \right\}.$$

In a system such as this, a template test case at sampling time,  $i$ , consists of a set of one or more test inputs, (possibly empty) sets of pre-condition(s), expected output(s), and expected post-condition(s). In this system, force  $F_i$  is the test input, while the angle  $\theta_i$  and angular velocity  $\dot{\theta}_i$  of the pendulum, as well as the position  $x_i$  and velocity  $\dot{x}_i$  of the cart along the  $x$ -axis, are pre-conditions. The expected test outputs are  $\theta_j$  ( $j$  can be the same as  $i$ ) and  $x_j$ , and the expected post-conditions are  $\dot{\theta}_j$  and  $\dot{x}_j$ . Other properties such as the state of the system, its failure or success, or safety properties such as its stability at a given time  $j$ , could also be expected post-conditions – we omit these for simplicity. A specific test case replaces the variables in the template with concrete values.

The hybrid model for this example, shown in Figure 1, has three acceptable modes (shown as ellipses) that model its discrete states, and six edges/transitions between modes that model its discrete dynamics or switches. Inside each mode, the first line displays the mode's name. The next two lines display flow conditions, and the fourth displays an invariant condition. The labels on each edge display guard conditions. The function  $z(\theta, \dot{\theta})$ , which calculates the total energy of the system, together with  $u_{max}$ , which is a constant and shows the maximum total energy that the CPS can have in order to remain stable, determine whether the CPS should remain in the same mode or change to another one. In other words, if the absolute value of  $z(\theta, \dot{\theta})$  is in the range of  $-u_{max}$  to  $u_{max}$ , then the inverted pendulum is stable; otherwise it is falling down, either left or right.

This hybrid model describes how the inverted pendulum functions, as follows. The CPS can begin in any of the

---

### Algorithm 1: HYTEST

---

**Inputs:** hModel: Hybrid Model,  
unConditions: Unacceptable Conditions,  
simData: Simulation Data,  
sysDyn: System and CPS Dynamics,  
simulationModel: Simulation model

**Output:** faults: Detected faults in the CPS

- 1 hModel=getHybridModelData();
- 2 unConditions= getUnacceptableConditions();
- 3 simData= getSimulationData();
- 4 sysDyn= getDynamics();
- 5 cGraph= genConditionsGraph(hModel,unConditions);
- 6 tConditions= genTestConditions(cGraph);
- 7 testcases=genTestCases(tConditions,simData,sysDyn);
- 8 [faults]=testCPS(testcases,simData,tConditions,simulationModels);
- 9 **return** faults

---

acceptable modes. Here we assume that the pendulum is initially in the upright position, i.e., mode *stabilize*, and when released the pendulum moves towards the left. Suppose force  $F$  moves the cart to the right to balance the total energy of the CPS and keep the pendulum stable, captured by the mode *stabilize*; in this case, the pendulum moves to the right. Now force  $F$  moves the cart to the left to balance the total energy of the CPS and stabilize the pendulum. If, for some reason, the total energy of the CPS is less than  $-u_{max}$ , i.e., the pendulum is falling to the left, the system will be in mode *max left*. Depending on the acceptable deviation the controller designer has considered for the modes *max left* and *max right*, the controller may or may not be able to stabilize the pendulum and return the CPS to mode *stabilize*.

### III. APPROACH

Algorithm 1 provides an overview of HYTEST. HYTEST receives information about a CPS's hybrid model, conditions that indicate the CPS's failure, simulation parameters, information on the CPS's dynamics, and a simulation model of the CPS. All of these are either required to design and develop the CPS or can be obtained easily from its requirements. The algorithm outputs the faults that are revealed during the CPS testing process.

HYTEST begins (line 1) by retrieving data about the hybrid model of the CPS. This data includes the total number of modes, the CPS goal(s), invariant conditions, guard conditions that show the transitions between modes, and variables in the hybrid model including their acceptable value range and precision. Next (line 2), HYTEST obtains a list of "unacceptable conditions": these are conditions that are not expected to occur during the operation of the CPS, or that would lead to a failure. If no unacceptable conditions are provided for the CPS, HYTEST temporarily sets the variable *unConditions* to null (Section III-A describes this step further). HYTEST next (lines 3-4) retrieves data about the simulation model used to test the CPS, and about the system's and CPS's dynamics including its state-space representation; transfer functions or Matlab code that implements the system's dynamics; and initial values, inputs, and simulation time, provided as Matlab "init" files. Using this information, HYTEST creates a

“condition graph” (line 5) and using this graph, generates test conditions (line 6).

HYTEST uses test conditions to partition the input space and then generate test cases (line 7). It passes these test cases, along with simulation data, to the testCPS function (line 8). The testCPS function implements a testing framework with which to test the CPS by running its simulation model, and ultimately returns the faults that are revealed by test cases during testing. We explain each of the foregoing steps in the subsections that follow.

### A. Unacceptable Condition Determination

To generate test cases and provide a test oracle, HYTEST utilizes “acceptable” and “unacceptable” conditions on variables in the CPS – we assume acceptable and, possibly, unacceptable conditions have all been identified by the system/controller designer and are available to HYTEST. *Acceptable conditions* are those that are known in the target CPS, lead to expected behavior of the CPS, and do not cause the CPS to fail. These conditions include all the invariants and guards found in the CPS hybrid model – in our example  $|z(\theta, \dot{\theta})| < u_{max}$ . *Unacceptable conditions* are those conditions that are not known/expected in the target CPS or that lead the CPS to a failure. In our example, these include range values for the variables in the CPS, e.g., the displacement of the cart from its initial position is greater than 3 m, so  $|x| > 3$  is an unacceptable condition. In Section III-B we explain what HYTEST does when unacceptable conditions are not known.

As noted earlier, it is difficult to predict all of the conditions a CPS will encounter, but the effect of those conditions is reflected in the values of the CPS’s states, which are all captured in the hybrid model as invariants and guard conditions. Because conditions, whether acceptable or unacceptable, set limitations and bounds on variables in the CPS, and because the fact that a condition is acceptable or not determines whether the CPS functions correctly or not, we believe that generating test cases using conditions will be effective for revealing faults in CPSs.

### B. Condition Graph Generation

To generate test cases using information about the hybrid model and unacceptable conditions, HYTEST generates a specific type of graph that we call a *condition graph*. A condition graph is a representation of a CPS that shows all acceptable, final, and failing modes in the CPS, along with all conditions that change the mode of the CPS from one to another and may lead the CPS to a failure or success.

HYTEST generates a condition graph in two sub-steps using the module genConditionGraph, shown in Algorithm 2. genConditionGraph receives a hybrid model and set of unacceptable conditions as its inputs and returns the condition graph. If unacceptable conditions are not known, the conjunction of the negation of all acceptable conditions are considered to be unacceptable conditions. For example, if the unacceptable condition is not known in our inverted pendulum example and  $|x| \leq 3$  and  $x \approx 0$  are two acceptable conditions, then HYTEST considers  $\sim (|x| \leq 3) \ \&\& \ \sim (x \approx 0)$  to be an unacceptable condition.

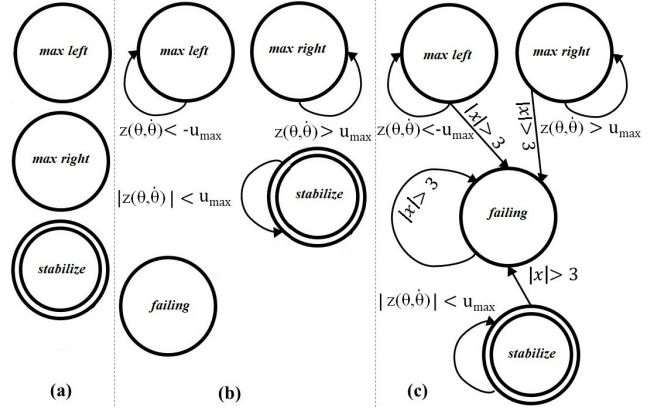

Fig. 3. Condition Graph Generation, Step 1: HYTEST (a) adds modes to the graph and recognizes the final mode(s); (b) adds one more mode to the graph as the failing mode and adds invariant conditions of the modes as self-loops; (c) adds unacceptable conditions to the edge between the acceptable and failing modes and to the self-loop on the failing mode.

In its first step, for each mode in the hybrid model, HYTEST adds the mode to the graph and adds its invariant conditions as self-loop edges (line 2). Next, if the goal conditions are the invariant(s) of the mode(s), HYTEST designates one or more acceptable modes as “final modes” (line 3) based on the conditions that the CPS designer sets as the goal of the CPS; otherwise it just saves the goal conditions for the next steps. In our inverted pendulum example, the goal of the final CPS is to stabilize the pendulum in the upward position and keep it in this position, so the condition of the final mode is  $|z(\theta, \dot{\theta})| < u_{max}$  and HYTEST designates the mode “stabilize” as the final mode. The result of this step is shown in Figure 3(a).

Next (line 4), HYTEST adds one extra mode to the set of CPS modes, designated as a “failing” mode. For any mode in the graph, HYTEST adds its invariant condition as a self-loop (line 5). The result of this step is shown in Figure 3(b).

Next (line 6), HYTEST generates the complete unacceptable conditions expression and augments the graph as follows. First, using the logical operator “—”, HYTEST joins all unacceptable conditions in the CPS and considers them as initial unacceptable conditions expressions. For our example, the initial unacceptable condition is  $(|x| > 3)$ . Second, for each mode that has unacceptable conditions, using the logical operator “—”, HYTEST combines unacceptable conditions for that mode with the initial expression. Our example did not include any unacceptable conditions of this type, but

---

#### Algorithm 2: Condition graph generation

---

```

1 genConditionGraph (hModel, unConditions)
   inputs: hModel: Hybrid Model,
           unConditions: Unacceptable Conditions
   output: cGraph: Conditions Graph
2 cGraph=addModes(hModel);
3 cGraph=determineCPSGoal(hModel, cGraph);
4 cGraph=addFailingMode(cGraph);
5 cGraph=addInvariants(cGraph, hModel);
6 cGraph=addUnacceptableConditions(cGraph, hModel);
7 cGraph=addEdges(cGraph, hModel);
8 cGraph=addLabels(cGraph, hModel);
9 return cGraph;

```

---

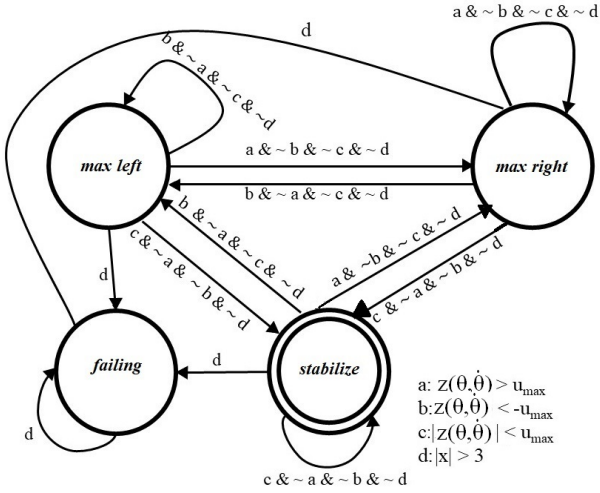

Fig. 4. Condition Graph Generation, Step 2

if the unacceptable condition of this type was  $(x == 0)$  then the unacceptable conditions expression would be  $(|x| > 3) \parallel (x == 0)$ . HYTEST adds this unacceptable condition expression to the graph on new edges from acceptable modes to failing modes and on a self-loop edge on the failing mode. In our Inverted Pendulum example, the unacceptable condition expression is  $|x| > 3$ , shown in Figure 3(c) as variable *d*. If there are no unacceptable conditions recognized by the system/controller designer or generated by HYTEST, then there is no unacceptable conditions expression and the failing mode will be a separate graph that includes just one node, and will be ignored by HYTEST. In such a case HYTEST recognizes faults in the CPS (if there are any) and issues “failed” verdicts as explained in Section III-E.

In its next step (line 7), HYTEST adds all the edges that exist between modes in the hybrid model that are missing in the condition graph, with no labels assigned to them. For example, by comparing Figure 3(c) with the hybrid model, i.e. Figure 1, we see that the edge from mode *max left* to mode *max right* in the hybrid model is missing and must be added to the condition graph. Next (line 8), the algorithm adds labels or completes them as follows. First, if an edge has no label, the algorithm adds its guard conditions as its label. Second, for all edges other than those that end in failing mode, using the logical operator “&”, the algorithm joins the label of the edge to the negation of the labels of all other outgoing edges of the mode. Then it adds the negation of unacceptable conditions expression, which is generated in line (line 6), using the same logical operator, i.e. “&”. For example, the label added to the edge from mode *max left* to mode *max right* is  $z(\theta, \dot{\theta}) > u_{max}$ , and the algorithm adds  $\& \sim z(\theta, \dot{\theta}) < -u_{max} \& \sim |z(\theta, \dot{\theta})| < u_{max} \& \sim |x| > 3$  to that edge. Figure 4 shows the condition graph after this step – for readability, complex conditions have been represented by variables as shown in the legend within the figure.

HYTEST has now generated the complete condition graph, as shown in Figure 4. This graph is the input for the next step.

---

**Algorithm 3: Test condition generation**

---

```

1 genTestConditions (cGraph)
  inputs: cGraph: Condition Graph
  output: tConditions: Test Conditions
  tConditions=[];
2
3 foreach edge  $e_i \in cGraph$  do
4   temp = source + “, “ + destination + “#” + labeli;
5   if type(destination) == failing then
6     temp.append(“@failed“);
7   else if type(destination) == final then
8     temp.append(“@passed“);
9   else if type(destination) == acceptable &&
    isEmpty(cGraph.finalMode) then
10    temp.append(“@acceptable“);
11  else
12    temp.append(“&~(“ , goalCondition, “)...
    ...@acceptable“);
13    tConditions.add(temp);
14    temp.append(“&(“ , goalCondition, “)@passed“);
15  end
16  tConditions.add(temp);
17 end
18 return tConditions;

```

---

### C. Test Condition Generation

*Test conditions* are the conditions in the condition graph that are used to generate test inputs and to determine whether the generated test inputs lead the CPS into final, acceptable, or failing modes.

Algorithm 3 presents our algorithm, *genTestConditions*, for generating test conditions. *genTestConditions* takes a condition graph as input. For each edge in the graph (line 3), *genTestConditions* obtains its source and destination modes and concatenates them as a formatted string (line 4), which is easy to parse when the approach needs to extract specific data from the test conditions. Next, *genTestConditions* obtains the edge’s label, which shows under what conditions the CPS changes mode from source to destination. These conditions are used later to generate values for the CPS variables to make the system change from one mode to another, so the algorithm adds the condition to the formatted string (line 4). Recall that HYTEST categorizes the modes as acceptable (any mode that is neither final nor failing), final, or failing. Using these categories, the algorithm recognizes (lines 5-15) the type of the destination mode (of the edge) and appends it to the formatted string (line 16), which helps the test oracle issue the correct test verdict for the test inputs. Recall also that if the goal conditions of the CPS are not the invariant(s) of any mode, then there is no final mode and HYTEST saves the goal condition(s). In this situation, the condition graph has just two types of modes: failing and acceptable. If the CPS is in any of the acceptable modes and the values of the CPS’s variables fit the goal condition(s) then the system has reached the goal and the state (which in the CPS includes mode and values) is considered to be final. Otherwise, it is considered to be acceptable. This is how lines 9-15 identify whether a test condition is an acceptable or passing one.

The following line illustrates a sample test condition that is generated by *genTestConditions* for our example and corre-

**Algorithm 4:** Test case generation

---

```

1 genTestCases ()
   inputs : tConditions: Test Conditions,
           simData: Simulation Data,
           sysDyn: CPS's and system's Dynamics
   output : testcases: Generated Test Cases
2 [TC1,testConditionsCovered]=genTestcasesCPS(
   testConditions,simulationData,CPSDynamics);
3 [TC2,testConditionsCovered]=genTestcasesSystem(
   testConditions,simulationData,systemDynamics,
   testConditionsCovered);
4 TC3=genTestcasesUncovTestConditions(
   testConditions,testConditionsCovered);
5 testcases= select(TC1,TC2,TC3);
6 return testcases;

```

---

sponds to the self-loop on the mode *stabilize*.

*stabilize, stabilize* # ( $|z(\theta, \dot{\theta})| < u_{max}$ ) &  $\sim (z(\theta, \dot{\theta}) > u_{max})$  &  $\sim (z(\theta, \dot{\theta}) < -u_{max})$  &  $\sim (x > 3)$ @passed

**D. Test Case Generation**

Algorithm 4, *genTestCases*, generates test cases. The algorithm receives test conditions, simulation data, and the CPS's and system's dynamics as input data, and outputs generated test cases.

The *genTestCases* algorithm proceeds in four major steps. In Step 1 (line 2), *genTestCases* invokes algorithm *genTestCasesCPS*. *genTestCasesCPS* (Algorithm 5) uses test conditions, simulation data, and the CPS's dynamics to generate an initial set of test cases. To this end, *genTestCasesCPS* (line 2) first obtains the response of the CPS to the control input provided as part of the CPS's dynamics in its init file, and obtains the outputs. The output values are either values of the variables in the hybrid model, such as  $\theta$ , or values that are used to calculate the values of the expressions in the hybrid model, such as  $\cos \theta$ . The algorithm checks all of the test conditions to find the outputs that fit them (line 4). (In other words, it uses the test conditions to partition the input space.) If the algorithm finds any output that fits a given test condition  $t_i$ , then it marks that test condition as covered (line 6) and extracts the type of the destination mode of the test condition, by extracting anything after the sign "@" from the test condition  $t_i$ , (line 7). This is considered to be the type of the initial mode of the CPS, and is used later by the test oracle to issue correct test verdicts. For each output that fits test condition  $t_i$ , the approach considers the output values as test inputs and generates a set (*outputs, type of initial mode,  $t_i$* ) as a test case and appends it to the test suite (lines 8-11). If there is at least one output that does not fit any test conditions, this means that the hybrid model provided is incorrect (line 14).

In Step 2 (line 3), *genTestCases* uses the uncontrolled system's dynamics along with the other inputs to generate a second set of test cases. The algorithm *genTestcasesSystem*() generates test cases in a manner similar to that used by *genTestcasesCPS*(). There are two differences between these algorithms. First, *genTestCasesSystem* generates test cases using the dynamics of the uncontrolled system, whereas *genTestcasesCPS*() uses the dynamics of the controlled system.

**Algorithm 5:** Test case generation, Step 1

---

```

1 genTestcasesCPS (testConditions, simulationData,
   CPSDynamics)
   inputs : Test Conditions, Simulation Data, CPS's
           Dynamics
   output : testCases1: Test Cases Generated using the
           Controlled Environment,
           testConditionsCovered: Test Conditions that are
           Covered by test suite testCases1
2 cpsOutputs=getCPSResponse(CPSDynamics);
3 foreach testCondition  $t_i \in$  testConditions do
4   indices=findOutputs( $t_i$ , cpsOutputs) ;
5   if  $\sim$ isEmpty(indices) then
6     testConditionsCovered $_i$ = true;
7     initialMode=extractAfter( $t_i$ , @) ;
8     foreach index  $j \in$  indices do
9       newTC = (cpsOutputs $_j$ , initialMode, i);
10      testCases1=
11        append(testCases1, newTC) ;
12    end
13 if there is any output that does not fit any test conditions
14   then
15     print("Wrong hybrid model!!!");
16 return testCases1;

```

---

Second, to avoid generating redundant test cases, *genTestCasesSystem* checks test conditions that are not covered by the test cases that have been generated by *genTestcasesCPS*().

In Step 3, if there are any test conditions that are not covered by the test cases generated in Step 1, these are used to generate additional test cases (line 4), i.e., a third set of test cases. In the first and second steps, all test conditions that are covered by outputs are marked, and it is possible to have test conditions that are not covered by any outputs. To cover these uncovered test conditions, HYTEST first uses the variables in the hybrid model, their acceptable value ranges, and their precisions to generate an input space that includes valid and invalid values for the variables in the hybrid model. For each variable, HYTEST takes the acceptable ranges of values, in the form of the range's boundaries, and generates another range in two steps:

$$1) \text{maxBound} = \max(|\text{boundries}_i|)$$

$$2) -2 * \text{maxBound} : \text{precision} : 2 * \text{maxBound}$$

This ensures that the resulting range includes invalid values as well as valid ones. In the second step, we can replace 2 with any number greater than 2, but because the goal of this step is to provide a range of valid and invalid values and *maxbound* and *minbound* are selected based on the boundaries of acceptable values, using a co-efficient greater than 2 just increases the range of invalid values. Since the test conditions are used to partition the input space, increasing the range of invalid values only results in larger numbers of invalid inputs without affecting the fault revealing ability of HYTEST (as we explain later in this article). This unnecessarily increases the time required to test the target CPS.

Next, HYTEST calculates the Cartesian product of the variables' value sets to find all possible combinations. Finally, it finds the test conditions that each resulting combination may fit in and generates test cases in the same manner as is done

for the first and second classes of generated test cases.

Finally, in Step 4, because the first three steps of genTestCases may return redundant (identical) test cases, genTestCases attempts to remove redundant test cases through a selection process. Before this process begins, genTestCases has classified the generated test cases using test conditions. Given this classification, the selection process proceeds in two steps. First, the process selects one test case per class (i.e., per test condition) in order to cover all the test conditions, i.e., all partitions of input spaces, which are all of the transitions in the condition graph. The test suite resulting from this step, however, may still contain redundant test cases depending on the extent to which invariants and guard conditions overlap. This necessitates a second step, in which genTestCases removes the redundant test cases from the test suite by finding the unique ones in terms of test inputs and initial modes.

A concrete test case for our inverted pendulum example looks like this:

$$testcase_i = \{-0.495502602162482, 2.88465092291609, 0.529831722628956, 1.33637906750083, passed\}.$$

The members of this set are the pendulum's angle, the pendulum's angular velocity, the cart position, the cart velocity, and the expected type of the mode that the CPS will be in when the its variables are set to these values (in this case the mode is passed ).

### E. Test Execution and Test Oracle Operation

The final step of Algorithm 1 (line 8) invokes algorithm testCPS, which executes generated test cases on the CPS. Algorithm 6 presents our algorithm, testCPS, that provides details on this step of the process.

The testCPS algorithm takes the generated test suite and simulation data as inputs and returns faults revealed during testing. testCPS begins by retrieving test cases and extracting test inputs (line 2) and the initial modes (line 3).

As already noted, the hybrid model has already been verified; i.e., all its modes/states are reachable, so HYTEST puts the CPS in different modes and transitions without any concern about their reachability. testCPS, on lines 4-6, for each test case, initially sets the values of the variables to the test input values of test cases to put the CPS in every possible acceptable, final, or failing mode and then checks the behavior of the CPS until the end of simulation.

As an example, using the concrete test case for our inverted pendulum CPS (which we have presented in Section III-D), HYTEST starts simulating the CPS from a "passing", i.e., final, state by setting the initial values of the CPS's variables to the values in the test case and simulates the CPS for the entire simulation time.

For each test input, testCPS receives the simulation output(s) as a set(s) of values with the length of the (simulation time)/(sampling time). Then, testCPS inspects the simulation outputs to see whether the CPS has stopped at a final mode through sequences of allowed transitions and whether the values of the variables fit the goal conditions.

To issue a test verdict for test cases, the test oracle behaves as follows. First, using the test conditions and the test output signal, the test oracle recognizes the possible modes of the

### Algorithm 6: Test execution and test oracle

```

1 testCPS (testcases, simData,)
  inputs: testcases: Test Cases,
          simData: Simulation Data,
          tConditions: Test Conditions,
          simulationModels: Simulation Models of CPS
  output: faults: Revealed Faults
2 testInputs=extractTestInputs(testcases);
3 initialMode= extractInitialMode(testcases);
4 foreach test input inputi ∈ testInputs do
5   try:
6     testOutput=simulateModel(inputi, simData);
7     possibleCPSModes=recognizeCPSModes(...
8       ...testOutput, tConditions);
9     foreach mode modej ∈ possibleCPSModes
10      do
11        if modej == null then
12          print("The hybrid model was not
13            designed correctly.");
14        else
15          if .isAllowed(modej, modej+1) then
16            faultsi ← true
17          else if modej contains failing then
18            faultsi ← true
19        end
20      if possibleCPSModes .contains "failing"
21      then
22        lastMode ←
23          thelastmode in possibleCPSModes;
24        else if lastMode contains final then
25          if initialMode ==
26            final || initialMode == acceptable
27          then
28            faultsi ← false
29          else
30            faultsi ← true
31        else
32          faultsi ← true
33      catch Exception:
34        faultsi ← true
35    end
36  end
37  return faults;

```

CPS at any sampling time (line 7) by checking the test outputs against test conditions. Since a test output at time  $j$  may fit in several test conditions, the CPS at time  $j$  can be in different modes and the real mode of the CPS depends on its real condition at testing time. At this point (lines 8-9), testCPS checks whether there is any test output with no modes assigned to it. In this case, the hybrid model was designed incorrectly, line10, because there is a behavior in the CPS that does not fit any modes/transitions represented in the hybrid model, i.e., the hybrid model missed a mode/transition. According to the modes in the condition graph, the modes and transitions (based on their destinations) of the CPS can be categorized into three groups: acceptable, final, and failing. Based on these groups, the test oracle issues test verdicts for the test cases as follows:

- Using the condition graph, the test oracle determines (lines 12-13) whether transitions between consecutive modes are allowed or not, i.e., transitions between modes of the test output at times  $i$  and  $i + 1$ . If the transition is not allowed then a failure occurred, e.g., there is an



overshoot in the CPS output values.

- If the possible modes of the CPS include “failing” in at least one sampling time, the test oracle issues a “failed” verdict for the test case (line 14-15).
- If the test verdict is not “failed”, the possible modes of the CPS at the last moment of the simulation include “final” and the initial mode in the test case includes “final” or “acceptable”, then the test oracle issues a “passed” verdict (lines 17-21).
- If the test verdict is not “failed”, and the possible modes of the CPS at the last moment of the simulation includes “final” and the initial mode in the test case include “failing”, then the test oracle issues a “failed” verdict (line 23).
- If the test verdict is not “failed” and the possible modes of the CPS at the last moment of the simulation include “acceptable”, then the test oracle issues a “failed” verdict (line 25), because the CPS was not able to reach its target, i.e. the final mode or goal conditions, within the simulation time. Recall that the simulation time is the time within which the CPS must reach the goal condition. Otherwise, the CPS fails even if it can reach the goal in a longer time. In our inverted pendulum system, although the modes “max left” and “max right” are both acceptable, the goal of designing such a CPS is to keep it in the “stabilized” mode; therefore, if this CPS is not in the mode “stabilized” at the end of the simulation, the CPS failed to reach its goal. In this case, although the CPS is in an acceptable mode at the end of the simulation, HYTEST recognizes a failure since the goal was not reached.
- If executing the simulation encounters any problem that leads to an exception, the test oracle issues a “failed” verdict, lines 26-27.

#### F. Implementation Details

We implemented HyTest using Java 1.8.0 and Matlab R2022. Algorithms 2 and 3 were implemented using Java and the rest of the implementation is in Matlab. The Java code takes a hybrid model and other inputs, parses them, and generates a condition graph and test conditions. The Matlab code obtains the test conditions and the rest of the inputs, generates and selects test cases, executes these test cases on the Simulink model of the CPS, and returns the test results.

### IV. EMPIRICAL STUDY

To evaluate HYTEST we conducted an empirical study, asking the following research questions:

- RQ1:** How effective is HYTEST at revealing faults in CPSs?  
**RQ2:** How efficient is HYTEST at testing CPSs?

#### A. Objects of Study

To conduct our study we require CPSs. HYTEST performs testing at the MiL level, and requires simulation models of our objects of study. To avoid possible threats to external validity that might occur were we to design simulation models of our

TABLE 1  
OBJECTS OF STUDY

	# of Simulink Blocks	# of Mutation Operators	# of Faulty Models
Cruise Control	16	5	26
Inverted Pendulum	11	4	20
Hexapod	348	6	191
Rooms and Heaters	24	8	56
Automatic Transmission	14	7	66

objects of study ourselves, we sought CPSs that came with simulation models. To find such CPSs we searched research monographs on related work. Ultimately, this process led us to select five CPSs.<sup>2</sup> Table 1 provides data on the selected CPSs.

“Cruise Control” is a cruise control system [64]. This system monitors the speed of a vehicle through sensors, increases and decreases the vehicle’s speed to match a set speed, and maintains that speed. “Inverted Pendulum” is the inverted pendulum system [65] introduced in Section II-C and used to illustrate the operation of HYTEST. “Hexapod” is a hexapod [66] – an autonomous legged robot that is able to move around its environment with high flexibility and stability. This robot can reach a preset goal and avoid preset obstacles on its way to the goal. “Rooms and Heaters” is a system [67] that controls transfer of moving heaters among adjacent rooms to maintain the temperature of the rooms within a desired range. Finally, “Automatic Transmission” is an automatic transmission system that controls an automobile’s speed and engine rpm [16]. The simulation models for all five of these CPSs are Simulink models, and they contain a wide range of block types including Integrator, Merge, Add, Transfer Function, If, State Chart, Relational and Logical Operators. The Simulink models of these CPSs have each been designed using different types of controllers; this allows us to examine whether HYTEST can generate test cases for CPS’s with different controllers.

For Inverted Pendulum we retrieved a hybrid model from [59] and for Cruise Control we followed the description provided in [64] to recreate its model. The hybrid model for Hexapod is from [66]. The hybrid models for Rooms and Heaters and Automatic Transmission are from [68] and [69].

To answer our research questions we require information on fault detection for our object CPSs. Unfortunately, no faults have been reported for these systems. For this reason we turned to a mutation-based approach for fault seeding, as has commonly been used in prior empirical studies of testing techniques, including techniques that operate on models (see, e.g., [3], [12], [19]).

Matinnejad et al. [70] provide a comprehensive list of Simulink fault patterns based on experiences reported by Delphi Engineers and from their review of the literature on CPSs. Based on this, they created a set of mutation operators for Simulink models. To create a set of faulty models, we used these mutation operators to inject mutations into the Simulink models for our objects of study, by applying each mutation operator to each of the blocks in the Simulink model to which it was applicable. Table 1 provides statistics on the numbers

<sup>2</sup>The CPSs we selected are all available via links provided in the relevant monographs, all of which are cited in this subsection.

of mutation operators we applied to the models (third column) and the number of faulty models obtained through this process (fourth column) for each of our objects of study.

## B. Variables and Measures

1) *Independent Variable*: Our independent variable is the test case generation technique used. We wished to compare HYTEST to state-of-the-art techniques. Our survey [9] provides information on techniques that are available with implementations; we have also reviewed related techniques that are not covered in the survey. Among the techniques reviewed, only one is similar in aim and features (the basis of the technique, the type of testing it performs, and the simulation level it operates on) to HYTEST, and that is SimCoTest [11].

To generate test cases, SimCoTest uses a meta-heuristic-based search algorithm that attempts to maximize diversity in test output signals that are generated by Simulink models. To address both continuous and discrete behaviors, SimCoTest generates test inputs as functions over time in Simulink models in an entirely black box manner. The technique provides manual test oracles that depend on engineers' estimates of acceptable deviations from the expected results. To this end, SimCoTest needs a fault free version of a model and obtains the output signal of such a model (as ground truth). SimCoTest validates/verifies CPSs at the MiL level while generating test cases for CPSs at the next levels (e.g., the SiL level), and it performs system testing. Although the authors of [11] do not directly mention CPSs in their paper, that paper focuses on an extension of their previous work that targeted CPSs and used CPSs in its evaluation, so we have selected it as our primary baseline technique.

Several other techniques discussed in our survey [9] fail to be relevant as baselines because they are different in terms of simulation level, test level, and/or supported product. (Since these techniques are discussed in detail in the survey, we refer readers there for details.) Several other techniques could potentially be relevant but were not provided with implementations. In principle, we could attempt to implement such techniques, but we could not guarantee that our implementations would faithfully capture the proposed algorithms. Also, there are several techniques that generate test cases for testing CPSs that have been proposed recently and are not included in the survey, that focus on specific types of CPSs [43]–[50]. For example, Moghadam et al. [43] propose a technique that generates critical test roads on which to test an autonomous-driving car. Finally, as noted earlier, there are many test case generation techniques that may be applicable to CPSs that have not been presented, implemented, or studied relative to CPSs; these are not viable choices as baseline techniques in this case.

As a second baseline technique we utilized a random test case generation technique. While such a technique is not necessarily practical in practice, an algorithmic technique, if it is to be beneficial, should outperform a purely random technique.

2) *Dependent Variables*: To assess the effectiveness of techniques, we calculate the percentage of faulty models in which the techniques are able to detect faults.

To assess efficiency we calculate *total testing time*; this is the sum of the time required to *generate and execute* the test cases for a CPS. In this study, we generate test cases only on the hybrid model, so we report the time required to do this as test case generation time. We execute test cases, however, on each of several faulty models, so we report test execution time as the average of the times required to execute test cases over each of these models.

## C. Study Operation

For each of the five objects of study HyTest first generated test cases, in the format discussed in Section III-D and then extracted the test inputs and initial modes from the test cases. Next, HyTest put the CPS in different initial states by setting the model's initial values to the test inputs, provided the initial mode for the test oracle, and executed the faulty models. We recorded the numbers of generated test cases, the faulty models in which faults were detected, the number of test executions, the test case generation time and the test execution time.

For SimCoTest, we determined input and output ranges. Also, the technique allows us to specify how much test case generation time to allow, and a number of final test cases. We set the test case generation time to the time that HYTEST required to generate test cases, and the number of test cases to the number of test cases that HYTEST generated for each of our objects of study. Because SimCoTest generates test cases based on output diversity, where there is more than one output we needed to take that into account when specifying a number of test cases in order to obtain the desired number. For example, the Rooms and Heaters CPS has three outputs. If HYTEST generates  $n$  test cases for this CPS, then for SimCoTest we set the number of test cases to  $\text{ceil}(n/3)$ .

For the Random technique, we randomly generated exactly as many random test cases as HYTEST generated to control for differences in numbers of test cases. To control for random elements of HYTEST and the random test case generation technique, following a recommendation in a similar study presented in [71], we repeated the foregoing processes 30 times for each of the object systems; hence, the results reported in Tables 3.a to 3.e for HYTEST and Random are the averages of results over 30 runs.

## D. Threats to Validity

*External validity* threats concern the generalization of our findings. As objects of study we selected five CPSs, so our results pertain to those CPSs and may not generalize beyond them. As baseline techniques we chose SimCoTest and random test case generation. Other techniques may compare differently. To assess fault detection abilities we relied on the insertion of mutations into Simulink models. Our mutations are based on those defined in earlier research in which they were derived based on experiences from Delphi Engineers and other sources, so they have some relevance to natural faults; nevertheless, results obtained using these may not match results on natural faults occurring in practice. The hybrid models obtained for our objects represent only five specific models. However, we did verify the simulation models against the hybrid models and specifications and made sure

both models behaved in accordance with their corresponding specifications.

*Internal validity* threats concern uncontrolled factors that may have affected our results. Errors in our implementation of HYTEST could result in the collection of incorrect data; to reduce this threat we tested our implementation rigorously. Randomness in the algorithms used by HYTEST and random test case generation could also affect results. To reduce this threat, we ran HYTEST and the Random technique 30 times for each object.

To allow HYTEST to operate on Simulink models, we modified them by adding input/output blocks to provide them with test inputs (as initial values from the Matlab workspace) and to obtain the test outputs that the test oracle needs. Because such a modification might change the output of the models and result in incorrect results, we reviewed the models' outputs to confirm that the CPSs' behaviors were not affected.

*Construct validity* threats concern our metrics and measures. Our metric for efficiency does not account for other costs related to testing such as time spent debugging.

### E. Results

Tables 3.a, 3.b, 3.c, 3.d, and 3.e provide data for the techniques considered, for each of the five objects of study, respectively. In each table, Column 1 lists the technique used to generate test cases, Column 2 shows the number of test cases that were generated by the technique, and Column 3 shows the amount of time each technique required to generate those test cases. Column 4 shows the average time required to execute test cases on each faulty model using all generated test cases. This column together with Column 3 present the components of total testing time; these are added to calculate total testing time, which is presented in Column 5, and used to answer RQ2. Columns 6 and 7 show the number and percentage of distinct faults that were revealed during the testing process; this data pertains to the effectiveness of techniques and used to answer RQ1.

Regarding RQ1, as Table 3.a shows, HYTEST was able to reveal all of the faults in Cruise Control while Random and SimCoTest revealed, respectively, 50% and 65% of the faults. Tables 3.b and 3.c show that on Inverted Pendulum and Hexapod, HYTEST was able to detect all of the faults, whereas Random and SimCoTest detected fewer than half. Table 3.d shows that on Rooms and Heaters, HYTEST revealed all of the faults while Random and SimCoTest revealed just 54% of the faults. As Table 3.e shows, HYTEST revealed all of the faults for Automatic Transmission, whereas Random and SimCoTest revealed around one third of the faults. Hence, HYTEST was more effective at revealing faults than either of the baseline techniques on all of our objects of study

Regarding RQ2, data in Column 5 shows that HYTEST required less testing time than the other two baseline techniques on all of our objects except Rooms and Heaters (see Table 3.d). On this CPS, Random required the least time to test the CPS and HYTEST required the second least time. It is clear from Column 3 that test case generation time is the factor that causes this difference. As noted in Section III-D, HYTEST generates test cases in four major steps and in the third step it

TABLE 3.a  
RESULTS FOR CRUISE CONTROL

	# of TCs	TC Gen Time	Test Exe. Time	Total Testing Time	# of Faults Revealed	Pct. of Faults Revealed
HyTest	11	0.053 m	0.038 m	0.091 m	26	100%
Random	11	0.702 m	0.043 m	0.745	13	50%
SimCoTest	11	0.053 m	0.040 m	0.093 m	17	65%

TABLE 3.b  
RESULTS FOR INVERTED PENDULUM

	# of TCs	TC Gen Time	Test Exe. Time	Total Testing Time	# of Faults Revealed	Pct. of Faults Revealed
HyTest	13	0.164 m	0.048 m	0.212 m	20	100%
Random	13	0.265 m	0.051 m	0.316 m	9	45%
SimCoTest	14	0.164 m	0.061 m	0.225 m	9	45%

TABLE 3.c  
RESULTS FOR HEXAPOD

	# of TCs	TC Gen Time	Test Exe. Time	Total Testing Time	# of Faults Revealed	Pct. of Faults Revealed
HyTest	20	0.073 m	0.601 m	0.674	191	100%
Random	20	0.506 m	0.659 m	1.165	80	42%
SimCoTest	20	0.073 m	1.086 m	1.159	74	39%

TABLE 3.d  
RESULTS FOR ROOMS AND HEATERS

	# of TCs	TC Gen Time	Test Exe. Time	Total Testing Time	# of Faults Revealed	Pct. of Faults Revealed
HyTest	43	11.462 m	0.843 m	12.485 m	56	100%
Random	43	0.332 m	3.612 m	3.944 m	30	54%
SimCoTest	45	11.462 m	2.609 m	14.071 m	30	54%

TABLE 3.e  
RESULTS FOR AUTOMATIC TRANSMISSION

	# of TCs	TC Gen Time	Test Exe. Time	Total Testing Time	# of Faults Revealed	Pct. of Faults Revealed
HyTest	15	2.068 m	0.358 m	2.426 m	66	100%
Random	15	0.365 m	10.467 m	10.832 m	22	33%
SimCoTest	15	2.068 m	7.512 m	9.580 m	21	32%

generates the input space using the Cartesian product operator, Depending on how many variables the hybrid model has, how large the ranges of acceptable values for those variables are, and what precision they have, the time required to generate that Cartesian product varies and the input size changes, and this can directly affect test execution time. Given the size of Hexapod in terms of variables, this accounts for the differences in that time. As a partial answer to RQ2, based on the the results of our study, HYTEST was more efficient at revealing faults on four of our objects of study than either of the baseline techniques. We discuss this further in Section V.

## V. DISCUSSION

While we were applying HYTEST to the original, unmutated Simulink models for all systems, HYTEST revealed two additional faults that the baseline techniques did not reveal. One of these faults occurred because of a disallowed transition between modes of the CPSs, which may be the result of sudden changes in the values; the other was caused by changing from a failing mode to an acceptable mode, which means the CPSs continued to operate after they failed. We consider the latter a failure because the requirements of the object of study involved included that it must halt when the CPS fails.

As discussed in Section IV-E, the test case generation time for Rooms and Heaters was greater than that for Random, primarily due to the time required to generate the program's

input space using a Cartesian product. This input space is required only if there are test conditions that are not covered by any test cases in the first two steps of test case generation. If all test conditions are covered in the first two steps, HYTEST will not proceed with the step that involves the Cartesian product, and its test case generation time will not include this expense.

In some cases it may be possible to set the initial values in a system's and CPS's dynamics to values that cover all possible modes and transitions in the hybrid model. For example, in Hexapod, the test conditions that were not covered by the generated test cases at the first two levels were the ones that led the CPS to the failing mode. Hence, if we set the initial values on the system's dynamics to values that lead the system to a failure, then all the test conditions to the failing mode will be covered in the second step, which uses the system's dynamic to generate an input space. These values are easily determined by the test engineer or system designer.

The test case generation process using HYTEST is performed just once, immediately after the hybrid model of the CPS is ready and before any simulation model has been designed, so the generation process can be run in parallel with the work on the simulation model, and then may add no real time to the overall development process.

Finally, since HYTEST was able to reveal all faults and they can be targeted and fixed at early stages of CPS development, i.e., at the MiL level, using HYTEST in these cases prevents the extra costs that would arise if those faults remained hidden until later stages of development process.

## VI. RELATED WORK

Several papers (e.g., [3], [11]–[22], [36]) present test case generation techniques for CPS's using simulation models, assuming the models have been designed correctly, so they can be used as ground truth models for generating test cases that can be used at the SiL and HiL levels. HYTEST, in contrast, uses hybrid models to generate test cases at the MiL level and to test simulation models of CPSs.

Several papers (e.g. [72]–[74]) present testing approaches that use models of hybrid systems without specifically considering CPSs. These approaches typically use hybrid models to generate test cases based on coverage to determine a systems' conformance with its specification. HYTEST, in contrast, directly targets CPSs.

Several papers (e.g., [23], [24]) ignore either the continuous or discrete dynamics of hybrid systems when generating test cases. Badban et al. [23] present an approach that generates abstract test cases for hybrid systems as paths through an abstract representation model of the system. Discrete dynamics are not included in the definition of the system; this leads to testing just continuous dynamics of CPSs. Matinnejad et al. [3] present an approach that generates test cases for continuous controllers but do not discuss controllers with mixed discrete-continuous behavior. Bender et al. [24] propose an approach that generates test cases using the discrete behavior of a system without considering continuous behavior. HYTEST, in contrast, targets both continuous and discrete behaviors of CPSs by using their hybrid models to generate test cases and test those CPSs.

Several approaches [38], [75]–[78] use predefined sets of behaviors (either correct or faulty) to generate test cases. These approaches restrict the test case generation process to behaviors that are known beforehand and ignore behaviors that the target system may exhibit under conditions not considered. Tan et al. [75] provide a test case generation approach that simulates the behavior of a system in its environment and generates test cases from the simulation trace. They then create a testing automaton for each test case, which supplies the test case during the execution of the system model and later on its implementation. Approaches proposed in [76]–[78] to test the conformance of hybrid systems' implementations with specifications use qualitative reasoning and model checking to generate test cases. They mutate the model of the system's specification to obtain faulty system behaviors, and generate traces that are used to create test cases. This limits testing to the set of mutation operators. HYTEST, in contrast, is not restricted to known behaviors and applies to all predefined and non-determined behaviors of CPSs.

Several approaches [26], [79]–[83] generate test cases using extended finite state machines (EFSM) or their variations, but contain no discussion about applications to CPSs. The primary difference between hybrid models and extended finite state machines is that in a hybrid model there is no start state, while in EFSMs there are start states. Also, EFSMs use a set of input symbols [84] whereas hybrid models do not. Therefore, we believe that additional work is required to determine whether these approaches are applicable to, and are effective and efficient, in testing CPSs. HYTEST, in contrast, directly targets CPSs.

There are several approaches that generate test cases for specific types of CPSs [43]–[50]. For example, Moghadam et al. [43] propose an approach that generates critical test roads on which to test an autonomous-driving car. HYTEST, in contrast is not limited to specific types of CPSs.

Several approaches, such as those presented in [21] and [85], focus on falsifying test cases and ignore passing ones. These approaches do not check whether the CPS functions correctly as specified. For example, Menghi et al. [21] propose an approach that generates test cases using falsification techniques, that generates an approximation of the system model and tries to find a falsifying input, i.e., an input that violates the requirement(s). HYTEST, in contrast, generates test cases that lead the CPS to failures and test cases that pass in order to examine both passing and failing behaviors.

Aerts et al. [34] propose an approach for generating conformance test cases using hybrid models of CPSs. Their approach assumes that guards are not time-dependent, which renders the approach non-applicable to CPSs modeled using timed automata. HYTEST does not have such restrictions.

Several test case generation approaches for CPSs (e.g., [3], [8], [11], [12], [15], [17]–[22], [25]–[34]) generate redundant test cases; these lead to unnecessary test executions and unneeded testing costs. In contrast, HYTEST assumes that test cases from the same partitions in input spaces are redundant and does not execute all of them.

Several approaches for testing CPSs (e.g., [8], [14], [16], [18], [20], [25], [26], [28], [32], [38]) rely on manual test

oracles or provide a test oracle that compares the test outputs against a ground truth. These test oracles are similar to traditional test oracles used to test non-reactive systems, whereas CPSs are reactive systems and need oracles that check the correctness of sequences of interactions with the environment. In CPSs, a standard correctness requirement is that all executions be allowed based on the system requirements and specifications. Checking the correctness of the final results against a ground truth may indicate a “failure” when the test results are not equal to the ground truth, whereas the CPS may have interacted with its environment acceptably and reached its goal. HYTEST supports the testing of reactive systems.

## VII. CONCLUSION

We have presented HYTEST, an approach for generating test cases for CPSs, that is accompanied by a test oracle. To evaluate the effectiveness and efficiency of HYTEST we studied its application to a set of CPSs, and compared its results to those of two baseline techniques: Random test case generation and SimCoTest. Our results show that HYTEST, with its test oracle, was able to expose more faults than the baseline techniques either in less time, or in a practically insignificant greater amount of time.

Flaky test cases are test cases that are non-deterministic in terms of their results, possibly due to uncertainties and changing conditions in a system. As mentioned earlier, HYTEST captures all possible conditions that the values of the variables of a CPS may encounter during its execution. Therefore, as future work, we intend to extend HYTEST to identify potential flaky tests.

We have studied HYTEST in relation to the testing of CPSs at the MiL level; however, we believe that the test cases thus generated could be effective at the SiL and HiL levels. Additional studies could be performed to assess this.

In our empirical study, we evaluated HYTEST on five CPSs of various (low, medium, high) complexity and our results showed that HYTEST was effective and efficient when testing them. Although we do not have any theoretical or practical evidence that HYTEST’s applicability and scalability might be limited on larger and more complex industrial CPSs, additional empirical work is needed to determine this.

## REFERENCES

- [1] R. Alur, *Principles of Cyber-Physical Systems*. MIT press, 2015.
- [2] M. S. Fisher, *Software Verification and Validation: An Engineering and Scientific Approach*. Berlin, Heidelberg: Springer-Verlag, 2006.
- [3] R. Matinnejad, S. Nejati, L. Briand, T. Bruckmann, and C. Poull, “Automated model-in-the-loop testing of continuous controllers using search,” in *Search Based Software Engineering*, G. Ruhe and Y. Zhang, Eds., 2013, pp. 141–157.
- [4] W. M. Taha, A.-E. M. Taha, and J. Thunberg, *What is a Cyber-Physical System?* Springer International, 2021, pp. 3–18.
- [5] T. A. Henzinger, M. K. Inan, and R. P. Kurshan, *The Theory of Hybrid Automata*. Berlin: Springer, 2000, pp. 265–292.
- [6] R. Alur, “Formal verification of hybrid systems,” in *Proceedings of the International Conference on Embedded Software*, 2011, p. 273–278.
- [7] P. J. Antsaklis and X. D. Koutsoukos, “Hybrid system control,” in *Encyclopedia of Physical Science and Technology (Third Edition)*, third edition ed., R. A. Meyers, Ed. New York: Academic Press, 2003, pp. 445–458.
- [8] M. A. Schneider, M.-F. Wendland, and L. Bornemann, “Gaining certainty about uncertainty,” in *Risk Assessment and Risk-Driven Quality Assurance*, J. Großmann, M. Felderer, and F. Seehusen, Eds., 2017, pp. 129–142.
- [9] Z. Sadri-Moshkenani, J. Bradley, and G. Rothermel, “Survey on test case generation, selection and prioritization for cyber-physical systems,” *Software Testing, Verification and Reliability*, vol. 32, no. 1, p. e1794, 2022.
- [10] H. B. Adeyemo, R. Bahsoon, and P. Tiño, “Surrogate-based digital twin for predictive fault modelling and testing of cyber physical systems,” in *Proceedings of the International Conference on Big Data Computing, Applications and Technologies*, 2022, pp. 166–169.
- [11] R. Matinnejad, S. Nejati, L. Briand, and T. Bruckmann, “Test generation and test prioritization for simulink models with dynamic behavior,” *IEEE Transactions on Software Engineering*, p. 25, 2018.
- [12] A. Arrieta, S. Wang, U. Markiegi, G. Sagardui, and L. Etxeberria, “Employing multi-objective search to enhance reactive test generation and prioritization for testing industrial cyber-physical systems,” in *Proceedings of the Genetic and Evolutionary Computation Conference Companion*, 2018, pp. 7–8.
- [13] R. Matinnejad, S. Nejati, L. C. Briand, and T. Bruckmann, “Automated test suite generation for time-continuous simulink models,” in *Proceedings of the International Conference on Software Engineering*, 2016, pp. 595–606.
- [14] A. Turlea, “Search based model in the loop testing for cyber physical systems,” in *Proceedings of the International Conference on Embedded and Ubiquitous Computing*, 2018, pp. 22–28.
- [15] R. Matinnejad, S. Nejati, L. Briand, T. Bruckmann, and C. Poull, “Search-based automated testing of continuous controllers: Framework, tool support, and case studies,” *Information and Software Technology*, vol. 57, pp. 705 – 722, 2015.
- [16] Qianchuan Zhao, B. H. Krogh, and P. Hubbard, “Generating test inputs for embedded control systems,” *IEEE Control Systems Magazine*, vol. 23, no. 4, pp. 49–57, 2003.
- [17] M. Lochau and U. Goltz, “Feature interaction aware test case generation for embedded control systems,” *Electronic Notes in Theoretical Computer Science*, vol. 264, no. 3, pp. 37 – 52, 2010.
- [18] H. Pohlheim, M. Conrad, and A. Griep, “Evolutionary safety testing of embedded control software by automatically generating compact test data sequences,” *SAE Transactions*, vol. 114, pp. 804–814, 2005.
- [19] A. Arrieta, S. Wang, U. Markiegi, G. Sagardui, and L. Etxeberria, “Search-based test case generation for cyber-physical systems,” in *Proceedings of the IEEE Congress on Evolutionary Computation*, June 2017, pp. 688–697.
- [20] A. A. Gadkari, A. Yeolekar, J. Suresh, S. Ramesh, S. Mohalik, and K. C. Shashidhar, “Automotgen: Automatic model oriented test generator for embedded control systems,” in *Computer Aided Verification*, A. Gupta and S. Malik, Eds., 2008, pp. 204–208.
- [21] C. Menghi, S. Nejati, L. Briand, and Y. Isasi, “Approximation-refinement testing of compute-intensive cyber-physical models: An approach based on system identification,” in *Proceedings of the International Conference on Software Engineering*, 10 2020.
- [22] J. Deshmukh, M. Horvat, X. Jin, R. Majumdar, and V. S. Prabhu, “Testing cyber-physical systems through bayesian optimization,” *ACM Transactions on Embedded Computer Systems*, vol. 16, no. 5s, pp. 170:1–170:18, Sep. 2017.
- [23] B. Badban, M. Fränzle, J. Peleska, and T. Teige, “Test automation for hybrid systems,” in *Proceedings of the International Workshop on Software Quality Assurance*, 2006, p. 14–21.
- [24] K. Bender, M. Broy, I. Péter, A. Pretschner, and T. Stauner, “Model based development of hybrid systems: Specification, simulation, test case generation,” *Analysis and Design of Hybrid Systems*, pp. 37–51, 2002.
- [25] M. Alenazi, N. Niu, W. Wang, and J. Savolainen, “Using obstacle analysis to support sysml-based model testing for cyber physical systems,” in *Proceedings of the International Model-Driven Requirements Engineering Workshop*, 2018, pp. 46–55.
- [26] S. Gören and F. J. Ferguson, “Test sequence generation for controller verification and test with high coverage,” *ACM Transactions on Design and Automation of Electronics Systems*, vol. 11, no. 4, p. 916–938, Oct 2006.
- [27] H. Araujo, G. Carvalho, M. R. Mousavi, and A. Sampaio, “Multi-objective search for effective testing of cyber-physical systems,” in *Software Engineering and Formal Methods*, P. C. Ölveczky and G. Salaün, Eds., 2019, pp. 183–202.
- [28] B. Cukic, B. Taylor, and H. Singh, “Automated generation of test trajectories for embedded flight control systems,” *International Journal*

- of Software Engineering and Knowledge Engineering*, vol. 12, pp. 175–200, 04 2002.
- [29] J. M. Carter, L. Lin, and J. H. Poore, “Automated functional testing of simulink control models,” in *Proceedings of the Workshop on Model-Based Testing in Practice*, 2008, pp. 41–50.
- [30] T. Ma, S. Ali, T. Yue, and M. Elaasar, “Testing self-healing cyber-physical systems under uncertainty: a fragility-oriented approach,” *Software Quality Journal*, vol. 27, no. 2, pp. 615–649, Jun 2019.
- [31] T. Kuroiwa, Y. Aoyama, and N. Kushiro, “Testing environment for cps by cooperating model checking with execution testing,” *Procedia Computer Science*, vol. 96, pp. 1341 – 1350, 2016.
- [32] L. Zhang, J. He, and W. Yu, “Test case generation from formal models of cyber physical system,” *International Journal of Hybrid Information Technology*, vol. 6, pp. 15–24, 2013.
- [33] R. Sinha, C. Pang, G. S. Martinez, J. Kuronen, and V. Vyatkin, “Requirements-aided automatic test case generation for industrial cyber-physical systems,” in *Proceedings of the International Conference on Engineering of Complex Computer Systems*, Dec 2015, pp. 198–201.
- [34] M. Reniers, A. Aerts, and M. Mousavi, “A tool prototype for model-based testing of cyber-physical systems,” in *Proceedings of the International Colloquium on Theoretical Aspects of Computing*, vol. 9399, 10 2015.
- [35] C. Murphy, Z. Zoomkawalla, and K. Narita, “Automatic test case generation and test suite reduction for closed-loop controller software,” Department of Computer and Information Science, University of Pennsylvania, Tech. Rep., January 2013.
- [36] R. Matinnejad, S. Nejati, L. C. Briand, and T. Bruckmann, “Effective test suites for mixed discrete-continuous stateflow controllers,” in *Proceedings of the Symposium on Foundations of Software Engineering*, 2015, pp. 84–95.
- [37] U. Markiegi, A. Arrieta, G. Sagardui, and L. Etxeberria, “Search-based product line fault detection allocating test cases iteratively,” in *Proceedings of the International Systems and Software Product Line Conference*, 2017, pp. 123–132.
- [38] N. Li and J. Offutt, “Test oracle strategies for model-based testing,” *IEEE Transactions on Software Engineering*, vol. 43, no. 4, pp. 372–395, 2017.
- [39] D. Humeniuk, G. Antoniol, and F. Khomh, “Data driven testing of cyber physical systems,” in *Proceedings of the International Workshop on Search-Based Software Testing*, 2021, pp. 16–19.
- [40] A. Chawla and S. Bak, “CPS testing using Stateless RRT,” in *Proceedings of the International Conference on Cyber-Physical Systems*, 2022, pp. 302–303.
- [41] Z. Ramezani, K. Claessen, N. Smallbone, M. Fabian, and K. Åkesson, “Testing cyber-physical systems using a line-search falsification method,” *IEEE Transactions on Computer-Aided Design of Integrated Circuits and Systems*, vol. 41, no. 8, pp. 2393–2406, 2022.
- [42] Y. Annapureddy, C. Liu, G. Fainekos, and S. Sankaranarayanan, “S-taliro: A tool for temporal logic falsification for hybrid systems,” in *Proceedings of the International Conference on Tools and Algorithms for the Construction and Analysis of Systems*, 2011, p. 254–257.
- [43] M. H. Moghadam, M. Borg, and S. J. Mousavirad, “Deeper at the sbst 2021 tool competition: Adas testing using multi-objective search,” in *Proceedings of the International Workshop on Search-Based Software Testing*, 2021, pp. 40–41.
- [44] F. Klück, L. Klampfl, and F. Wotawa, “GABezier at the SBST 2021 Tool Competition,” in *Proceedings of the International Workshop on Search-Based Software Testing*, 2021, pp. 38–39.
- [45] D. Humeniuk, G. Antoniol, and F. Khomh, “SWAT tool at the SBST 2021 Tool Competition,” in *Proceedings of the International Workshop on Search-Based Software Testing*, 2021, pp. 42–43.
- [46] R. Ferdous, C.-k. Hung, F. Kifetew, D. Prandi, and A. Susi, “EvoMBT at the SBST 2022 Tool Competition,” in *Proceedings of the International Workshop on Search-Based Software Testing*, 2022, pp. 51–52.
- [47] L. L. L. Starace, A. Romdhana, and S. Di Martino, “GenRL at the SBST 2022 Tool Competition,” in *Proceedings of the International Workshop on Search-Based Software Testing*, 2022, pp. 49–50.
- [48] E. Castellano, S. Klikovits, A. Cetinkaya, and P. Arcaini, “FreneticV at the SBST 2022 Tool Competition,” in *Proceedings of the International Workshop on Search-Based Software Testing*, 2022, pp. 47–48.
- [49] D. Humeniuk, G. Antoniol, and F. Khomh, “AmbieGen tool at the SBST 2022 Tool Competition,” in *Proceedings of the International Workshop on Search-Based Software Testing*, 2022, pp. 43–46.
- [50] S. Yan and M. Fan, “AdaFrenetic at the SBST 2022 Tool Competition,” in *Proceedings of the International Workshop on Search-Based Software Testing*, 2022, pp. 41–42.
- [51] D. Harel and H. Kugler, *Some Thoughts on the Semantics of Biocharts*. Berlin, Heidelberg: Springer-Verlag, 2010, p. 185–194.
- [52] P. Černý, T. A. Henzinger, and A. Radhakrishna, *Quantitative Simulation Games*. Berlin, Heidelberg: Springer-Verlag, 2010, p. 42–60.
- [53] T. A. Henzinger, “What’s decidable about hybrid automata?” *Journal of Computing Systems Science*, vol. 57, no. 1, p. 94–124, aug 1998.
- [54] “Simulink website,” <https://www.mathworks.com/products/simulink.html>, accessed: 2020-8-24.
- [55] “Britannica website,” <https://www.britannica.com/science/scientific-modeling>, accessed: 2019-3-13.
- [56] A. V. Lamsweerde, “Formal specification: A roadmap,” in *Proceedings of the Conference on The Future of Software Engineering*, 2000, pp. 147–159.
- [57] E. A. Emerson, “Temporal and modal logic,” in *Formal Models and Semantics*. Elsevier, 1990, pp. 995–1072.
- [58] T. Nummenmaa, A. Tiensuu, E. Berki, T. Mikkonen, J. Kuitinen, and A. Kultima, “Supporting agile development by facilitating natural user interaction with executable formal specifications,” *SIGSOFT Software Engineering Notes*, vol. 36, no. 4, pp. 1–10, Aug. 2011.
- [59] “Inverted Pendulum,” <https://www.cs.bgu.ac.il/~inhs122/wiki.files/hybrid-automata3.pdf>, accessed: 2022-2-22.
- [60] J. Duran, “What is a simulation model?” *Minds and Machines*, 03 2020.
- [61] G. Dubois, *Modeling and Simulation: Challenges and Best Practices for Industry*. CRC Press, 2018.
- [62] M. Broy, B. Jonsson, J.-P. Katoen, M. Leucker, and A. Pretschner, *Part III. Model-Based Test Case Generation*. Berlin, Heidelberg: Springer Berlin Heidelberg, 2005, pp. 277–279.
- [63] O. Boubaker, “The inverted pendulum: A fundamental benchmark in control theory and robotics,” in *Proceedings of the International Conference on Education and e-Learning Innovations*, 2012, pp. 1–6.
- [64] “Crusie Control,” <https://ctms.engin.umich.edu/CTMS/index.php?example=CruiseControl&section=SystemModeling>, accessed: 2022-1-19.
- [65] “Inverted Pendulum,” <https://ctms.engin.umich.edu/CTMS/index.php?example=InvertedPendulum&section=SystemModeling>, accessed: 2022-1-19.
- [66] M. Khazaei, M. Sadedel, and A. Davarpanah, “Behavior-based navigation of an autonomous hexapod robot using a hybrid automaton,” *Journal of Intelligent Robotics Systems*, no. 2, jun 2021.
- [67] A. Fehnker and F. Ivančić, “Benchmarks for hybrid systems verification,” in *Hybrid Systems: Computation and Control*, R. Alur and G. J. Pappas, Eds., 2004, pp. 326–341.
- [68] “Hybrid Model for Automatic Transmission and Thermostat1,” <https://web.ece.ucsb.edu/~hespanha/ece229/Lectures/Lecture2.pdf>, accessed: 2023-1-11.
- [69] “Hybrid Model for Automatic Transmission and Thermostat2,” [https://people.kth.se/~kallej/papers/eolss\\_6.43.28.1.pdf](https://people.kth.se/~kallej/papers/eolss_6.43.28.1.pdf), accessed: 2023-1-11.
- [70] R. Matinnejad, S. Nejati, L. C. Briand, and T. Bruckmann, “Automated test suite generation for time-continuous simulink models,” in *Proceedings of the International Conference on Software Engineering*, 2016, pp. 595–606.
- [71] M. Hutchins, H. Foster, T. Goradia, and T. Ostrand, “Experiments of the effectiveness of dataflow- and controlflow-based test adequacy criteria,” in *Proceedings of the International Conference on Software Engineering*, 1994, p. 191–200.
- [72] M. van Osch, “Hybrid Input-Output Conformance and Test Generation,” in *Revised Selected Papers of the Sixth International Workshop on Formal Approaches to Testing of Software and International Workshop on Runtime Verification*, vol. 4262, 2006, pp. 70–84.
- [73] A. A. Julius, G. E. Fainekos, M. Anand, I. Lee, and G. J. Pappas, “Robust test generation and coverage for hybrid systems,” in *Proceedings of the International Conference on Hybrid Systems: Computation and Control*, 2007, p. 329–342.
- [74] T. Dang and T. Nahhal, “Coverage-guided test generation for continuous and hybrid systems,” *Formal Methods in System Design*, vol. 34, pp. 183–213, 2009.

- [75] L. Tan, J. Kim, O. Sokolsky, and I. Lee, "Model-based testing and monitoring for hybrid embedded systems," in *Proceedings of the International Conference on Information Reuse and Integration.*, 2004, pp. 487–492.
- [76] H. Brandl, M. Weiglhofer, and B. K. Aichernig, "Automated conformance verification of hybrid systems," in *Proceedings of the International Conference on Quality Software*, 2010, pp. 3–12.
- [77] B. K. Aichernig, H. Brandl, E. Jöbstl, and W. Krenn, "Model-based mutation testing of hybrid systems," in *Formal Methods for Components and Objects*, F. S. de Boer, M. M. Bonsangue, S. Hallerstede, and M. Leuschel, Eds., 2010, pp. 228–249.
- [78] B. K. Aichernig, H. Brandl, and F. Wotawa, "Conformance testing of hybrid systems with qualitative reasoning models," *Electronic Notes in Theoretical Computer Science*, vol. 253, no. 2, pp. 53–69, 2009, proceedings of the Fifth Workshop on Model Based Testing.
- [79] A. S. Kalaji, R. M. Hierons, and S. Swift, "Generating feasible transition paths for testing from an extended finite state machine," in *Proceedings of the International Conference on Software Testing Verification and Validation*, 2009, pp. 230–239.
- [80] K.-T. Cheng and A. Krishnakumar, "Automatic functional test generation using the extended finite state machine model," in *Proceedings of the Design Automation Conference*, 1993, pp. 86–91.
- [81] J. Li and W. Wong, "Automatic test generation from communicating extended finite state machine cefsm)-based models," in *Proceedings of the International Symposium on Object-Oriented Real-Time Distributed Computing.*, 2002, pp. 181–185.
- [82] V. Santiago, N. L. Vijaykumar, D. Guimaraes, A. S. Amaral, and E. Ferreira, "An environment for automated test case generation from statechart-based and finite state machine-based behavioral models," in *Proceedings of the International Conference on Software Testing Verification and Validation Workshop*, 2008, pp. 63–72.
- [83] J. Wang, H. Li, T. Lv, T. Wang, and X. Li, "Functional test generation guided by steady-state probabilities of abstract design," in *Proceedings of the Design, Automation Test in Europe Conference Exhibition*, 2014, pp. 1–4.
- [84] K. T. Cheng and A. S. Krishnakumar, "Automatic functional test generation using the extended finite state machine model," in *Proceedings of the International Design Automation Conference*, 1993, p. 86–91.
- [85] Y. Annpureddy, C. Liu, G. Fainekos, and S. Sankaranarayanan, "S-taliro: A tool for temporal logic falsification for hybrid systems," in *Tools and Algorithms for the Construction and Analysis of Systems*, P. A. Abdulla and K. R. M. Leino, Eds., 2011, pp. 254–257.