

# Towards training music taggers on synthetic data

Nadine Kroher

Time Machine Capital Squared Ltd.  
London, United Kingdom  
nadine@tmc2.ai

Steven Manangu

Time Machine Capital Squared Ltd.  
London, United Kingdom  
steven@tmc2.ai

Aggelos Pikrakis

Department of Informatics  
University of Piraeus  
Piraeus, Greece  
pikrakis@unipi.gr

**Abstract**—Most contemporary music tagging systems rely on large volumes of annotated data. As an alternative, we investigate the extent to which synthetically generated music excerpts can improve tagging systems when only small annotated collections are available. To this end, we release *GTZAN-synth*, a synthetic dataset that follows the taxonomy of the well-known *GTZAN* dataset while being ten times larger in data volume. We first observe that simply adding this synthetic dataset to the training split of *GTZAN* does not result into performance improvements. We then proceed to investigating domain adaptation, transfer learning and fine-tuning strategies for the task at hand and draw the conclusion that the last two options yield an increase in accuracy. Overall, the proposed approach can be considered as a first guide in a promising field for future research.

**Index Terms**—music information retrieval, genre detection, music tagging, domain adaptation, generative music

## I. INTRODUCTION

Systems which can automatically classify or tag music tracks are an essential component of large-scale music and multimedia indexing pipelines. Recent methods commonly rely on deep architectures which are either trained end-to-end on large annotated datasets (i.e. [1]) or pre-trained on large volumes of real-world audio data and then fine-tuned for various downstream tasks on smaller collections (i.e. [2], [3]). Although both approaches have shown promising results, they still rely on large volumes of labelled data to effectively pre-train or train end-to-end deep neural networks, a prerequisite which comes at great cost. Manual labelling is a time-consuming and tedious task and crowd-sourced or user-contributed annotations are often noisy or inconsistent. To alleviate the problem, recent approaches commonly employ data augmentation strategies (see i.e. [4]) which create variants of training instances by applying small modifications, i.e. pitch shifting or time stretching. While data augmentation does generally yield improvements, the augmented examples are still strongly correlated with the originals and do not prevent overfitting to the extent that adding new data would.

In an attempt to overcome the dependence on annotated data further, we explore an alternative strategy that makes use of synthetically generated music to train a tagging system. Similar approaches have been adopted by computer vision systems to address tasks [5] for which annotated data is hard to assemble, as it is for example the case with defect

detection in the steel industry [6], vessel classification from overhead imagery [7] or medical image analysis [8]. In the audio domain, [9] recently demonstrated that environmental sound classification can be improved by augmenting real-world datasets with synthetic examples generated with text-to-audio models.

In order to explore a similar approach in the music domain, we recently conducted a preliminary proof-of-concept experiment which involved only a small taxonomy of five perceptually easy to distinguish genres [10], which showed promising results. Based on these findings, we now extend our work to *GTZAN* [11], a small genre classification dataset, and explore various strategies for training on synthetic music data. Specifically, we first create *GTZAN-synth*, a collection of artificially generated music excerpts that follows the *GTZAN* taxonomy while being 10 times larger in data volume. We make all code for reproducing and scaling this collection publicly available to foster further research into this direction.

In addition, we explore several strategies towards improving the classification of a deep convolutional neural network on the *GTZAN* dataset by incorporating synthetic music excerpts into the training procedure. Our experiments cover a wide spectrum of options, including the simple integration of the synthetically generated data with the training split of *GTZAN*, the investigation of transfer learning and fine-tuning strategies, and a domain adaptation [12] mechanism to mitigate the distributional shift between real and synthetic data.

## II. RELATED WORK

### A. Music tagging

Music tagging systems analyse audio content in order to automatically annotate music tracks with high-level descriptors related to mood (i.e. “melancholic” or “upbeat”), genre (i.e. “rock” or “jazz”) or instrumentation (i.e. “string quartet” or “saxophone”). Most recent methods rely on deep neural network architectures, such as convolutional neural networks [13] and transformers [14], which are usually trained end-to-end on large annotated music collections like the Million Song Dataset [15] or the Magna Tag-a-Tune dataset [16]. Other approaches leverage representations learned in a supervised setting [3] on even larger datasets and then formulate specific tagging problems as downstream tasks which are solved via transfer learning. In both scenarios, large volumes of annotated

Aggelos Pikrakis is also a scientific advisor to Time Machine Capital Squared Ltd.

data are required, which may not be available for every use-case.

In order to overcome this need, some recent efforts have focused on self-supervised techniques (partially [17] or fully [18]) to learn audio representations. While this approach, which is also commonly used in natural language processing, has shown promising results, we explore in this paper the radically different idea of leveraging generative music systems to create artificial training data. To the best of our knowledge, with the exception of our previous exploratory study [10], this is the first work aimed at investigating frameworks for training music taggers on synthetically generated music datasets.

### B. Generative music systems

The recent advancements in generative artificial intelligence for natural language processing and image analysis tasks have also driven rapid improvements of state of the art systems that can generate music excerpts conditioned on text and melody prompts. Prominent generative music models include Jukebox [19], MusicLM [20], Jen-1 [21] and MusicGen [22]. In this study, we focus on MusicGen, for which pre-trained models are publicly available via the *Audiocraft*<sup>1</sup> library.

While the distribution of synthetically created music via streaming services or its use in movies, TV or social media content poses legal issues [23] and has raised controversial discussions from an ethical point of view [24], we believe that there is unexplored potential in leveraging such systems for the creation of synthetic training data for tagging and analysis models.

### C. Domain adaptation

Although generative systems for natural language and image content have become very sophisticated over the recent years and are now capable of producing convincing output, generative music systems, while advancing rapidly, are still limited in their ability to produce realistic music tracks and are highly relevant to the input prompt. Consequently, with a view on training music taggers, it is reasonable to expect a content distribution shift between real and synthetic data.

This issue has also been addressed in other domains, mainly in computer vision, via the so-called domain adaptation (DA) methods, which essentially introduce additional loss terms during the training stage to ensure that a machine learning model trained partially or fully on synthetic data will generalise its performance to real world data. For a comprehensive review of different methods on various use-cases, training frameworks and domains, we refer to [12]. In the context of music, existing work on domain adaptation has been limited to specific use-cases that do not involve synthetic data, i.e. cross-cultural emotion recognition [25] or the compensation of differences among microphones for the purposes of piano transcription [26].

For the music tagging task at hand, we investigate the method proposed in [27], which addresses supervised DA in

neural network training via an additional loss term that operates on a bottleneck layer and essentially acts as a contrastive loss that forces intermediate representations from real and synthetic data of the same class to be in close proximity in a Euclidean sense while maintaining large Euclidean distances to instances of different classes.

## III. DATA

Our experiments make use of two datasets, the well-known *GTZAN* [11] genre detection dataset and *GTZAN-synth*, a synthetic dataset which we generated using the MusicGen [22] generative music system. *GTZAN-synth* follows the *GTZAN* class taxonomy but it is ten times larger.

### A. Real music dataset

During the early days of music tagging, the *GTZAN* dataset was widely used as a benchmark collection to evaluate and compare competing approaches. It contains a total of 1000 music excerpts of length 30s belonging to 10 genres (e.g., “blues”, “classical” or “rock”), with each genre being represented by 100 tracks. The dataset, including audio files and metadata, is publicly available<sup>2</sup> via the Kaggle platform.

In our experimental evaluation, we use artist-filtered validation splits proposed in [28] which are available on GitHub<sup>3</sup>.

### B. Synthetic music dataset

In order to study the suitability of synthetically generated music for training tagging systems and foster future work on this topic, we release the synthetic music dataset *GTZAN-synth*. Following the *GTZAN* taxonomy, we create genre-specific prompts that are used to condition the medium-sized MusicGen model. Compared to the original *GTZAN*, we scale by factor of 10, thus generating 1000 tracks per genre.

MusicGen is controllable via text prompts and while its generative process is to a certain degree stochastic, e.g. the prompt “a rock song” will give different results if run repeatedly, we observed during our initial experiments that large volumes of excerpts generated with a single prompt do not exhibit sufficient diversity. Consequently, the main challenge in generating a synthetic music dataset lies in the creation of a large volume of genre-specific text prompts that yield sufficient variety while maintaining genre-specific characteristics.

During initial experimentation, we also observed that MusicGen does not appear to generate vocals, even if prompted to do so. In addition, we noticed that prompts mentioning vocals often lead to output artefacts. As a result, we are restricted to generating instrumental examples.

To assemble an adequate number of text prompts for the MusicGen synthesis engine, we used a large language model (LLM) of the GPT-3 [29] family which can be accessed via

<sup>2</sup><https://www.kaggle.com/datasets/andradaolteanu/gtzan-dataset-music-genre-classification>

<sup>3</sup>[https://github.com/julianofoleiss/gtzan\\_sturm\\_filter\\_3folds\\_stratified/](https://github.com/julianofoleiss/gtzan_sturm_filter_3folds_stratified/)

<sup>1</sup><https://github.com/facebookresearch/audiocraft/>

the OpenAI API<sup>4</sup>. To avoid confusion, we will refer to the text input that drives the GPT-3 LLM as the *LLM-prompt* and the text guidance input to the MusicGen model as the *MusicGen-prompt*. Figure 1 depicts our prompt engineering pipeline along with an example.

We make the recipe for generating *LLM-prompts*, the generated 10k *LLM-prompts*, as well as code for generating the music excerpts with MusicGen publicly available<sup>5</sup>.

1) *LLM-prompt engineering*: We used the *gpt-3.5-turbo* model available via OpenAI’s chat completion API and set the temperature parameter to 0.5 to ensure sufficient variety over consecutive runs. The model takes an optional system prompt as an additional input which steers the overall behaviour of the model with respect to tone and style of interaction. Here, we used the following short system prompt: *You are a music expert writing short textual descriptions for songs. When engineering the LLM-prompt, we aimed at enforcing the generation of prompts that are limited to instrumental music, that mention the genre specifically and that describe various aspects of a music track. We experimentally found that the following LLM-prompt, where {genre} is a placeholder for the respective genre, yielded stable and convincing results: Write a description for an instrumental {genre} track. The description is a single sentence. It mentions that it is an instrumental {genre} track and gives details on tempo and instruments.*

2) *MusicGen-prompt engineering*: While most of the generated textual descriptions yielded convincing output when used to guide MusicGen, we observed that simply mentioning the genre once in the prompt did not guarantee a good alignment with the target class. We experimented with different prompt engineering strategies and observed that the best option for forcing the model to generate music excerpts that are prototypical for a particular genre is to simply prepend the genre several times to the prompt.

Based on this observation, we generated the *MusicGen-prompts* by concatenating two repetitions of the class name with the *LLM-prompt* as follows: *{genre} {genre} {LLM-prompt}*.

3) *Music generation*: Finally, in order to generate synthetic music excerpts, we employ the medium-sized version of the pre-trained MusicGen model, which has around 1.5B parameters, and condition it on the *MusicGen-prompts*. The model operates on top of the EnCodec tokenizer [30] which decodes tokens from 4 codebooks at a sample rate of 50 Hz to raw audio with a sampling rate of 32 kHz.

#### IV. MODEL ARCHITECTURE

Since the aim of this paper is not to propose a novel genre tagging method but rather to explore the potential of using synthetically generated data, our neural network design roughly follows the MusiCNN architecture described in [1] which was intended for end-to-end training of music taggers on large volumes of data.

The network operates on 96-band mel-spectrograms extracted from 10s of audio with a sampling rate of 16kHz, a window size of 512 samples and a hop size of 256 samples. The input is then processed by a first layer of parallel convolutional filters of different kernel shapes which are designed to learn different temporal and timbral features. The resulting feature maps are then pooled across the full frequency axis, concatenated and processed by further convolutional layers with residual connections and pooling operations before being passed through a normalised dense layer with 512 units and a final softmax classification layer with 10 units corresponding to the 10 genre classes. The architecture is shown in Figure 2. For a detailed description of the motivation behind the design choice the reader is referred to [1].

In our experimental evaluation, we train the model end-to-end and also in transfer learning and fine-tuning settings. In the case of transfer learning, the entire network is pre-trained on a large dataset and then only the penultimate dense layer and the final classification layer are trained from scratch on the smaller dataset with all other layers keeping their weights frozen. In the fine-tuning scenario, the entire network is first trained on a large collection and then training for all weights is resumed on the smaller collection.

#### V. SUPERVISED DOMAIN ADAPTATION

In order to compensate for potential distributional discrepancies between synthetic and real music data, we experiment with the supervised domain adaptation approach proposed in [27]. We can describe the genre classification network as  $f = g \circ h$ , where  $g : \mathcal{X} \rightarrow \mathcal{Z}$  takes the mel-spectrogram  $\mathcal{X}$  as input and maps it to the penultimate dense layer  $\mathcal{Z}$ , which we will treat as an intermediate feature representation. The classification layer  $h : \mathcal{Z} \rightarrow \mathcal{Y}$  maps this intermediate representation  $\mathcal{Z}$  to the final classifier output  $\mathcal{Y}$ .

Without any counter measures, any distributional shift between real  $X_r$  and synthetic  $X_s$  inputs can potentially propagate to the intermediate representation, resulting in discrepancies between  $\mathcal{Z}_r$  and  $\mathcal{Z}_s$ . In order to drive the network towards learning feature representations which encode commonalities between the two domains, we employ a contrastive loss  $\mathcal{L}_{SA}$  in addition to the classification loss  $\mathcal{L}_{CLS}$ .  $\mathcal{L}_{SA}$  encourages semantic alignment rather than domain-specific alignment of the intermediate feature representation.

Given a synthetic instance  $x_s^i$ , we can compute the contrastive loss by comparing its embedding to that of a real sample  $x_r^j$  of the same label and to that of a real sample  $x_r^k$  of a different label, where  $y^i = y^j$  and  $y^i \neq y^k$  as follows:

$$d(g(x_s^i, x_r^j)) = \frac{1}{2} \|g(x_s^i) - g(x_r^j)\|^2 \quad (1)$$

and

$$d(g(x_s^i, x_r^k)) = \frac{1}{2} \max(0, m - \|g(x_s^i) - g(x_r^k)\|^2) \quad (2)$$

where  $m$  denotes a margin parameter related to the separability in the embedding space and the semantic alignment

<sup>4</sup><https://openai.com/blog/openai-api>

<sup>5</sup>URL will be inserted upon paper acceptance

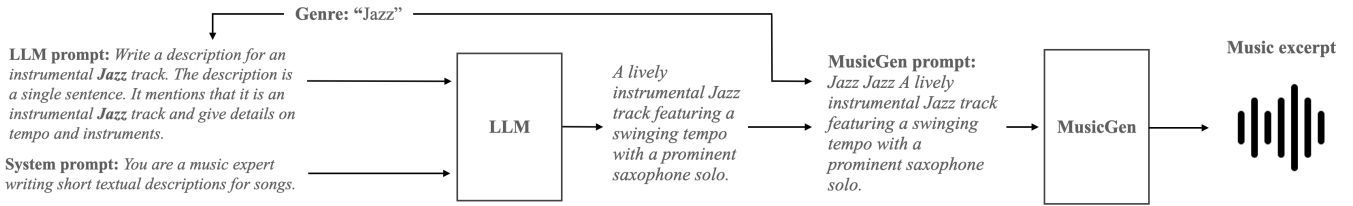

Fig. 1. Schematic representation of the proposed prompt engineering pipeline. For a given music genre, we use an LLM to generate genre-specific track descriptions. After some additional processing, these serve as input to MusicGen, a model for text-conditioned music generation.

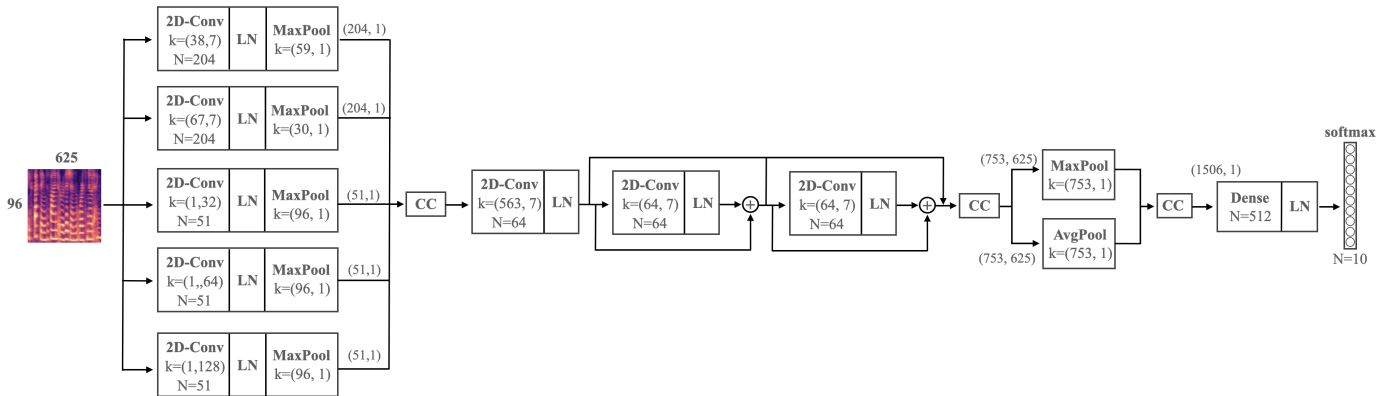

Fig. 2. Schematic representation of the model architecture which takes a mel-spectrogram as input and predicts the music genre in a multi-class classification task. **2D-Conv**: two-dimensional convolutional layer. **LN**: layer normalization. **CC**: concatenation. **MaxPool**: maximum pooling. **AvgPool**: average pooling.

loss becomes  $\mathcal{L}_{SA} = d(g(x_s^i, x_r^j)) + d(g(x_s^i, x_r^k))$ . In practice, we did not observe a difference between comparing to a single randomly selected target instance versus computing the average distance over all target samples as originally suggested by [27]. The second option is computationally very inefficient since the forward pass over all target samples has to be computed at each training step.

Finally, both loss terms can be combined as  $\mathcal{L} = \gamma \mathcal{L}_{SA} + (1 - \gamma) \mathcal{L}_{CLA}$ , where  $\gamma$  is a balancing factor which controls the relative weight of each term.

## VI. EXPERIMENTAL EVALUATION

In order to assess the potential of using synthetically generated music for training tagging systems, we run a series of experiments. For all settings, we train with a batch size of 4 and use the Adam [31] optimizer with an initial learning rate of 0.001, except for the fine-tuning setup where we decrease the initial learning rate to 0.0001. For the domain adaptation experiment, we set the margin to  $m = 2$  and the balance parameter to  $\gamma = 0.7$ . We furthermore use an early stopping criterion based on the classifier’s categorical cross-entropy loss with a patience period of 5 epochs and select the best performing model for evaluation. For the GTZAN dataset, where excerpts are of length 30s, we use a random 10s excerpt during training and the central 10s segment during validation.

For all experiments evaluated on the GTZAN dataset, we report mean and standard deviation of the categorical accuracy and of the categorical cross-entropy loss over the three vali-

ation splits proposed in [28]. When evaluating on synthetic data, we report mean and standard deviation over three random splits instead. All results are shown in Table I

TABLE I  
RESULTS OF THE EXPERIMENTAL EVALUATION. WE REPORT MEAN  $\mu$  AND STANDARD DEVIATION  $\sigma$  OF THE CATEGORICAL ACCURACY AND OF THE CATEGORICAL CROSS-ENTROPY LOSS OVER THE THREE ARTIST-FILTERED VALIDATION SPLITS PROPOSED IN [28].

System	Accuracy $\mu(\sigma)$	Loss $\mu(\sigma)$
E2E-real	46.7%(5.2%)	1.61(0.05)
E2E-synth	90.6%(1.6%)	0.34(0.02)
E2E-add	47.3%(4.6%)	1.74(0.05)
E2E-DA	47.6%(6.0%)	1.54(0.06)
TL	52.6%(3.3%)	1.40(0.06)
FT	54.8%(6.2%)	1.39(0.12)

First, we train and evaluate the model solely on the GTZAN dataset (**E2E-real**). Given the relatively large number of network parameters and the rather small dataset volume, we observe that the model overfits early and yields a mean accuracy of 46.7%. We also train and evaluate the same model on the larger GTZAN-synth dataset (**E2E-synth**) and observe a much higher mean accuracy of 90.6%.

While the result on the synthetic data appears encouraging, it does not guarantee that this classifier will generalise well to real-world music excerpts. It is for example possible that the synthetic music excerpts only represent a narrow fraction of the distribution of real music examples of the same genre. Another possibility is that the generative model causes artefacts or

characteristics that are not found in real-world examples, thus causing distributional discrepancies between real and synthetic data. The fact that such issues do indeed exist is confirmed when we repeat the first experiment and simply add *GTZAN-synth* to the training splits of *GTZAN* (**E2E-add**). Here, we observe that the mean accuracy on the *GTZAN* validation does not seem to improve (47.3%) and the loss even slightly worsens (1.74 vs. 1.61).

In an attempt to mitigate any distributional discrepancies between real and synthetic data, we repeat the previous experiments but employ the DA method (**E2E-DA**) described in Section V. We first visualise the intermediate representations after the penultimate layer with and without the additional DA loss term by approximating a two-dimensional representation using the t-sne [32] algorithm. The resulting plot in Figure 3 (a) reveals that there does indeed appear to be a distributional discrepancy between real and synthetic data which seems to largely disappear when DA is used (Figure 3 (b)). However, the results do not indicate a significant improvement in classification accuracy (47.6%) and only the loss appears to have somewhat improved (1.54). One reason for this behaviour could be that by driving synthetic data towards the real-world examples, the lack of variety in the training dataset persists and thus generalisation does not improve.

As a next step, we investigate if the model trained solely on synthetic data (**E2E-synth**) can be adapted for to real world data via transfer learning or fine-tuning. In the transfer learning experiment (**TL**), we freeze the convolutional layers from **E2E-synth** and only train the last two layers on *GTZAN*. For this setup, we observe an increase in mean accuracy to 52.6%. When we fine-tune on *GTZAN* by initialising the network with the weights from **E2E-synth** and by resuming training on all layers, we obtain an even slightly higher increase in mean accuracy to 54.8%. This indicates that training on synthetic data allows the network to learn useful features that aid in learning downstream tasks.

While these last two experiments demonstrate that synthetic data can help to improve performance of deep architectures on small datasets, it is worth noting that the results still do not reach those reported for systems that rely on transfer learning from large annotated datasets (i.e. 82.1% reported by [33]) or more lightweight end-to-end systems (i.e. 65.8% reported by [34]).

## VII. CONCLUSIONS

We have investigated the use of artificially created music excerpts for training tagging systems on the example of a genre classification task. To this end, we release *GTZAN-synth*, a collection of synthetic music excerpts that follows the taxonomy of the well-known *GTZAN* dataset but is 10 times larger. In a series of experiments, we first demonstrated that simply adding synthetic data during training does not yield a significant performance improvement. We furthermore investigated domain adaptation, transfer learning and fine-tuning and showed that the two last options are suitable methods for increasing the performance of deep architecture trained on

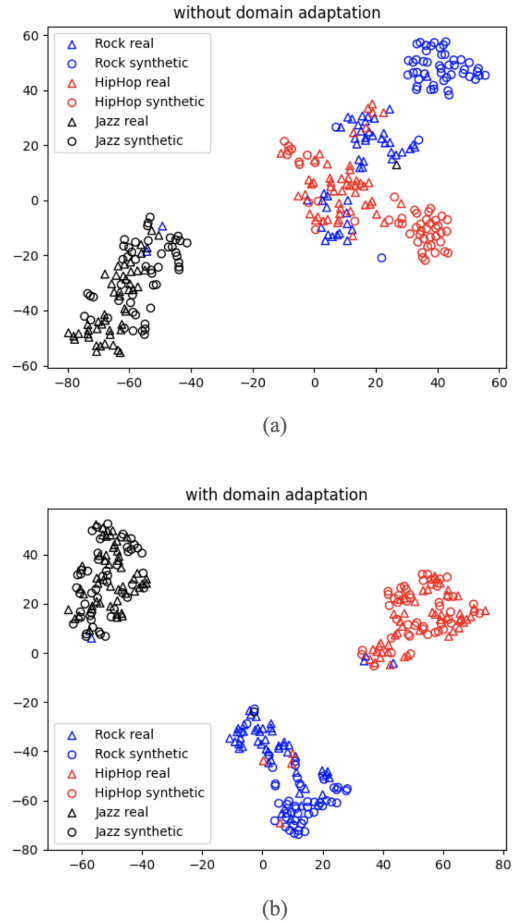

Fig. 3. t-sne visualisations of intermediate representations of a subset of real and synthetic data with (bottom) and without (top) DA for three genres.

small datasets. We believe that these findings together with the release of *GTZAN-synth* can foster future research into this direction, for example on advanced prompt engineering for generative music systems, on the influence of scaling the amount of synthetic data or on extending this work to other custom tagging tasks.

## REFERENCES

- [1] J. Pons, O. Nieto, M. Prockup, E. M. Schmidt, A. F. Ehmann, and X. Serra, “End-to-end learning for music audio tagging at scale,” in *19th International Society for Music Information Retrieval Conference (ISMIR2018)*, 2018.
- [2] J. Pons and X. Serra, “musicnnc: Pre-trained convolutional neural networks for music audio tagging,” *arXiv preprint arXiv:1909.06654*, 2019.
- [3] P. Alonso-Jiménez, X. Serra, and D. Bogdanov, “Efficient supervised training of audio transformers for music representation learning,” *arXiv preprint arXiv:2309.16418*, 2023.
- [4] B. McFee, E. J. Humphrey, and J. P. Bello, “A software framework for musical data augmentation.” in *ISMIR*, vol. 2015. Citeseer, 2015, pp. 248–254.
- [5] K. Man and J. Chahl, “A review of synthetic image data and its use in computer vision,” *Journal of Imaging*, vol. 8, no. 11, p. 310, 2022.
- [6] A. Boikov, V. Payor, R. Savelev, and A. Kolesnikov, “Synthetic data generation for steel defect detection and classification using deep learning,” *Symmetry*, vol. 13, no. 7, p. 1176, 2021.

- [7] C. M. Ward, J. Harguess, and C. Hilton, "Ship classification from overhead imagery using synthetic data and domain adaptation," in *OCEANS 2018 MTS/IEEE Charleston*. IEEE, 2018, pp. 1–5.
- [8] Y.-j. Kim, H. C. Cho, and H.-c. Cho, "Deep learning-based computer-aided diagnosis system for gastroscopy image classification using synthetic data," *Applied Sciences*, vol. 11, no. 2, p. 760, 2021.
- [9] F. Ronchini, L. Comanducci, and F. Antonacci, "Synthesizing soundscapes: Leveraging text-to-audio models for environmental sound classification," *arXiv preprint arXiv:2403.17864*, 2024.
- [10] N. Kroher, H. Cuesta, and A. Pikrakis, "Can musicgen create training data for mir tasks?" *arXiv preprint arXiv:2311.09094*, 2023.
- [11] G. Tzanetakis and P. Cook, "Musical genre classification of audio signals," *IEEE Transactions on speech and audio processing*, vol. 10, no. 5, pp. 293–302, 2002.
- [12] A. Farahani, S. Voghoei, K. Rasheed, and H. R. Arabnia, "A brief review of domain adaptation," *Advances in data science and information engineering: proceedings from ICDATA 2020 and IKE 2020*, pp. 877–894, 2021.
- [13] M. Won, A. Ferraro, D. Bogdanov, and X. Serra, "Evaluation of cnn-based automatic music tagging models," *arXiv preprint arXiv:2006.00751*, 2020.
- [14] M. Won, K. Choi, and X. Serra, "Semi-supervised music tagging transformer," *arXiv preprint arXiv:2111.13457*, 2021.
- [15] T. Bertin-Mahieux, D. P. Ellis, B. Whitman, and P. Lamere, "The million song dataset," in *Proceedings of the 12th International Conference on Music Information Retrieval (ISMIR 2011)*, 2011.
- [16] E. Law, K. West, M. I. Mandel, M. Bay, and J. S. Downie, "Evaluation of algorithms using games: The case of music tagging," in *ISMIR*. Citeseer, 2009, pp. 387–392.
- [17] Y. Li, R. Yuan, G. Zhang, Y. Ma, C. Lin, X. Chen, A. Ragni, H. Yin, Z. Hu, H. He *et al.*, "Map-music2vec: A simple and effective baseline for self-supervised music audio representation learning," *arXiv preprint arXiv:2212.02508*, 2022.
- [18] R. Castellon, C. Donahue, and P. Liang, "Codified audio language modeling learns useful representations for music information retrieval," *arXiv preprint arXiv:2107.05677*, 2021.
- [19] P. Dhariwal, H. Jun, C. Payne, J. W. Kim, A. Radford, and I. Sutskever, "Jukebox: A generative model for music," *arXiv preprint arXiv:2005.00341*, 2020.
- [20] A. Agostinelli, T. I. Denk, Z. Borsos, J. Engel, M. Verzett, A. Caillon, Q. Huang, A. Jansen, A. Roberts, M. Tagliasacchi *et al.*, "Musiclm: Generating music from text," *arXiv preprint arXiv:2301.11325*, 2023.
- [21] P. Li, B. Chen, Y. Yao, Y. Wang, A. Wang, and A. Wang, "Jen-1: Text-guided universal music generation with omnidirectional diffusion models," *arXiv preprint arXiv:2308.04729*, 2023.
- [22] J. Copet, F. Kreuk, I. Gat, T. Remez, D. Kant, G. Synnaeve, Y. Adi, and A. Défossez, "Simple and controllable music generation," *Advances in Neural Information Processing Systems*, vol. 36, 2024.
- [23] J. Smits and T. Borghuis, "Generative ai and intellectual property rights," in *Law and Artificial Intelligence: Regulating AI and Applying AI in Legal Practice*. Springer, 2022, pp. 323–344.
- [24] J. Barnett, "The ethical implications of generative audio models: A systematic literature review," in *Proceedings of the 2023 AAAI/ACM Conference on AI, Ethics, and Society*, 2023, pp. 146–161.
- [25] Y.-W. Chen, Y.-H. Yang, and H. H. Chen, "Cross-cultural music emotion recognition by adversarial discriminative domain adaptation," in *2018 17th IEEE International Conference on Machine Learning and Applications (ICMLA)*. IEEE, 2018, pp. 467–472.
- [26] F. Bittner, M. Gonzalez, M. L. Richter, H. M. Lukashevich, and J. Abeßer, "Multi-pitch estimation meets microphone mismatch: Applicability of domain adaptation," in *ISMIR, 2022*, pp. 477–484.
- [27] S. Motiian, M. Piccirilli, D. A. Adjeroh, and G. Doretto, "Unified deep supervised domain adaptation and generalization," in *Proceedings of the IEEE international conference on computer vision*, 2017, pp. 5715–5725.
- [28] J. H. Foleis and T. F. Tavares, "Texture selection for automatic music genre classification," *Applied Soft Computing*, vol. 89, p. 106127, 2020. [Online]. Available: <http://www.sciencedirect.com/science/article/pii/S1568494620300673>
- [29] L. Floridi and M. Chiriatti, "Gpt-3: Its nature, scope, limits, and consequences," *Minds and Machines*, vol. 30, pp. 681–694, 2020.
- [30] A. Défossez, J. Copet, G. Synnaeve, and Y. Adi, "High fidelity neural audio compression," *arXiv preprint arXiv:2210.13438*, 2022.
- [31] D. P. Kingma and J. Ba, "Adam: A method for stochastic optimization," *arXiv preprint arXiv:1412.6980*, 2014.
- [32] L. Van der Maaten and G. Hinton, "Visualizing data using t-sne." *Journal of machine learning research*, vol. 9, no. 11, 2008.
- [33] J. Lee, J. Park, K. L. Kim, and J. Nam, "Samplecnn: End-to-end deep convolutional neural networks using very small filters for music classification," *Applied Sciences*, vol. 8, no. 1, p. 150, 2018.
- [34] F. Medhat, D. Chesmore, and J. Robinson, "Masked conditional neural networks for audio classification," in *Artificial Neural Networks and Machine Learning–ICANN 2017: 26th International Conference on Artificial Neural Networks, Alghero, Italy, September 11–14, 2017, Proceedings, Part II 26*. Springer, 2017, pp. 349–358.