

Voting by mail: a Markov chain model for managing the security risks of absentee voting

Carmen A. Haseltine and Laura A. Albert *

Electrical & Computer Engineering and Industrial & Systems Engineering
University of Wisconsin-Madison
Madison, Wisconsin 53706
Email: laura@engr.wisc.edu

Abstract

The scrutiny surrounding vote-by-mail (VBM) in the United States has increased in recent years, raising concerns about the integrity and security of absentee voting. This paper addresses these issues by introducing a dynamic mathematical modeling framework for performing a risk assessment of VBM processes. We introduce a discrete-time Markov chain (DTMC) to model the VBM process and assess election performance and risk with a novel layered network approach that considers the interplay between VBM processes, malicious and non-malicious threats, and security mitigations. The time-inhomogeneous DTMC framework captures dynamic risks and evaluates performance over time. The DTMC model accounts for a spectrum of outcomes, from unintended voter errors to sophisticated, targeted attacks, representing a significant advancement in the risk assessment of VBM planning and protection. A case study based on real-world data from Milwaukee County, Wisconsin, is used to evaluate the DTMC model. The analysis includes the development of attack scenarios to assess the system's resilience and the evaluation of security measures. The analysis suggests that ballot drop boxes and automatic ballot notification systems are crucial for ensuring secure and reliable operations.

1 Introduction

Democracies rely on the ability of the general public to vote on critical issues pressing their society. In the United States (US), there are generally two methods by which the public can cast a ballot. Voters can travel to their designated polling location where they receive and cast a ballot on an election day, referred to as in-person voting. Voters can also vote absentee, and many of those who vote absentee choose to accept and cast a ballot through the United States Postal Service (USPS), the vote-by-mail (VBM) system. Historically, in-person voting has been the primary method of voting in the US. However, VBM has experienced significant growth in recent years, accounting for

*Corresponding author

20-percent of votes cast in the 2016 General Election in the US and 46-percent of votes cast in the 2020 General Election that occurred during the COVID-19 pandemic [6].

The popularity of VBM among voters has highlighted the need for an efficient, reliable, and secure plan for this voting modality. The increased volume of VBM ballots in the 2020 General Election revealed issues such as mailing delays, security concerns, and accessibility to voting infrastructure. Since 2020, Colorado, Oregon, and six other states have adopted “all-mail” voting, which involves pro-actively sending mail-in ballots to all registered voters [17]. Additionally, many US states have proposed or are considering legislation that has implications for VBM operations and security [16]. Election planning requires a moderate understanding of the security needs crucial for VBM processes and, by extension, core election infrastructure.

The VBM process involves a complex interplay of time-sensitive tasks among election offices, voters, and the USPS. These tasks comprise the election procedures and policies managed at the state and local levels. As a result, VBM processes can vary depending on the location. There is no practical way to physically test absentee election operations at scale before an election, which drives the need for enhanced security planning tools and risk analysis models. Additionally, the VBM process occurs over several months, making it vulnerable to temporal issues occurring at specific times, such as USPS mail processing delays causing ballots to arrive after an election day when they are no longer counted (in many US states), as well as in-person absentee voting that is only available on specific days leading up to an election. We integrate these risks into a dynamic mathematical model of the VBM system capable of evaluating different threats and measures to mitigate them.

This paper presents a methodology to support VBM risk analysis by introducing a novel discrete-time Markov chain (DTMC) for VBM to capture dynamic election performance. The modeling approach employs attack tree models of malicious (intentional) and non-malicious (unintentional) risks and security mitigations. Attack tree models have been used to characterize risks in prior studies on voting by mail security [32, 23]. A novel aspect of the DTMC framework is that it models the linkages between attack trees, security mitigations, and VBM processes to characterize and predict dynamic VBM performance under various threat scenarios and operating conditions. Furthermore, the DTMC model leverages attack trees that provide a structured approach to capturing malicious and non-malicious risks to VBM systems. The DTMC framework highlights how different types, intentions, and timings of attacks impact overall VBM performance and security. Using real-world data from Milwaukee County in the 2020 General Election, we calibrate and validate the model and demonstrate its applicability to forecast the performance of the VBM process under different conditions and policy scenarios. Contributions of this paper include the following.

1. We formulate a new DTMC using a layered network approach that evaluates election performance and risk over time.
2. We construct a new dataset of VBM mitigations and their attributes to link each mitigation to attacks and the VBM process.

3. We perform a detailed analysis of the DTMC model using a real-world case study based on Milwaukee County, Wisconsin. We study multiple threat scenarios to shed light on how mitigation strength impacts performance of the VBM process.

The structure of this paper is as follows. Section 2 summarizes the existing research on election security modeling. Section 3 summarizes the components of VBM, and Section 4 introduces the DTMC and performance measures. Section 5 details the case study of Milwaukee County, Wisconsin. Section 6 summarizes the case study findings, and the paper concludes in Section 7 with policy implications.

2 Literature review

The vast majority of election security modeling research focuses on in-person voting. A stream of papers in this area assesses the impact of operational decisions and resource allocation on election performance using methodologies such as discrete event models and model optimization [30, 29]. However, these approaches are not adaptable to address VBM, which requires its own analytical framework due to its unique operations and vulnerabilities that differ from in-person voting. An exception is Schmidt and Albert [25] who formulate an integer programming model to determine the locations of drop boxes used in VBM. However, Schmidt and Albert [25] narrowly focus on the location of drop boxes and the collection of ballots from drop boxes. In contrast, our paper focuses on the entire VBM process, including operations leading up to an election.

Research on the allocation of voting machines to polling locations for in-person voting has been extensively explored through various methodologies. One notable example is a study by Yang et al. [39] who uses discrete event simulation to model election day processes, combining queuing theory and optimization to address resource concerns. Similarly, Li et al. [10] employ simulation optimization to assess the impact of voting machine distribution on voter queue times. The significance of these studies extends to a tailored risk assessment for VBM. Schmidt and Albert [24] apply discrete event simulation to understand the effects of safety measures implemented during the COVID-19 pandemic on wait times and other election performance indicators. In addition, McIntyre [11] focus on optimizing the polling locations to reduce voter waiting times. These approaches underscore the importance of modeling and optimization in improving election processes, informing the development of risk assessment methodologies for election infrastructure. Specific to the VBM system, Scala et al. [22] develop a detailed model of the VBM process, which meticulously outlines its various components and the physical journey of ballots. The Cybersecurity and Infrastructure Security Agency (CISA) conducted a comprehensive assessment of mail-voting security for the 2020 General Election [5], contributing to efforts to identify and mitigate VBM-related risks during the pandemic.

A growing body of literature characterizes threats to the voting process using attack trees. Attack trees help identify and prioritize potential vulnerabilities in a system, making them an essential tool in cybersecurity planning and risk mitigation. Attack trees are fundamental in cyber-

security for visualizing vulnerabilities and potential attacker paths [26]. An attack tree starts with the primary goal of the attacker (the root) and branches out into different methods or steps that the attacker might employ (the leaves). This branching structure often incorporates logic gates like AND and OR to demonstrate how different actions might combine to lead to the attack goal. Terminal attack nodes, are the leaf nodes of an attack tree that initiate the attack on the system. The University of South Alabama [32] present a risk analysis report for election systems and models security threats to the VBM using attack trees that capture all possible vulnerabilities in the VBM system. Scala et al. [23] expand on the VBM threat trees and adds to tree logic enumerating all terminal attack nodes to account for the new mechanisms available, such as drop boxes and in-person absentee voting. Haseltine et al. [8] build upon this body of literature to identify mitigation strategies and policies that protect the VBM process, accounting for linkages to attack trees relevant to VBM processes. Our DTMC framework utilizes these attack trees and mitigations.

Attack and fault trees have been used for the risk analysis of in-person voting processes. Yasinisac and Pardue [40] illustrate how attack trees have been deployed to analyze risks, including malicious cyber-attacks targeting voting machines. These methodologies consider both equipment failures and cybersecurity vulnerabilities, offering a broad view of potential threats. In a similar vein, Simidchieva et al. [28] use fault trees to evaluate the in-person election process, with a particular emphasis on ballot counting and vulnerability detection. However, these papers do not differentiate between malicious and non-malicious attacks, solely focus on in-person voting, and represent risks as static by excluding temporal analysis.

Our study aims to fill gaps in knowledge by introducing a time-inhomogeneous DTMC model to support VBM risk analysis over an election cycle. The DTMC model differentiates between malicious and non-malicious threats, considers risk in a dynamic system, and evaluates the effectiveness of mitigation strategies. This DTMC modeling approach employs layered networks to model interdependent components within the VBM process. The DTMC model is uniquely tailored to address the inherent complexities of VBM, efficiently accommodating simplified process components, diverse attack scenarios, and corresponding mitigation strategies. Furthermore, the integration of VBM procedures within a cyber-physical systems (CPS) framework highlights the processes and threats that span cyber and physical components as well as the interdependence of the overall system. This is consistent with the observations of Rinaldi et al. [20], who examine the interconnected nature of modern critical infrastructure. Voting systems are integral to social and political structures and therefore require a holistic security approach to maintain their integrity [21]. Our paper aligns with these perspectives to provide a comprehensive and dynamic approach to safeguarding the voting process.

3 Markov Chain Framework

We introduce a DTMC framework to evaluate VBM performance and assess its associated risks which captures the dynamic nature of the VBM process that unfolds over several months. We

adopt a layered approach in the DTMC model, comprising a *process layer*, an *attacks layer*, and a *mitigations layer*. This layered structure reflects the physical components, process, and informational interdependencies among the ballots affected by attacks, mitigations, and recourse actions. Furthermore, the DTMC allows for a nuanced understanding of the impact of policy implementations on the VBM process. In this section, we describe these three layers and discuss VBM performance. Although exact details of VBM operations may vary slightly according to a particular municipality in the US, the overall VBM process is similar between municipalities. Therefore, our high-level model of the VBM process effectively captures the fundamental dynamics and can be used to identify insights under different settings.

3.1 Process Layer

First, we introduce seven process states that capture the movement of ballots in the process layer and define the operation of the VBM system. Each of these process states is also a state in the DTMC, and the states represent the change in physical location of the ballot over time. The voter requests a ballot in state *I*, the election office then fulfills this request in state *II* and mails an unmarked ballot to the voter. In state *III* the unmarked ballot is handled by the United States Postal Service (USPS) and is in transit to the voter. In state *IV* the unmarked ballot reaches the voter, however, it is up to the voter when the marked ballot is filled out and returned. In state *V* the voter selects the method of return for the marked ballot. Standard operation for returning a ballot is a transition to state *VI* via the USPS. Alternatively, the voter could return the ballot by drop box, if drop boxes are available. The final process state *VII* occurs when the marked ballot reaches the election office and is held until processing on election day. The ballot process is summarized by the following states:

- **I:** Ballot requested by voter.
- **II:** Unmarked ballot sent from election office.
- **III:** Unmarked ballot in-transit via USPS.
- **IV:** Voter marks ballot.
- **V:** Voter returns marked ballot via USPS or drop box.
- **VI:** Marked ballot in-transit via USPS.
- **VII:** Marked ballot processed at election office and held to be counted on election day.

3.2 Final Ballot States

At the end of the VBM process, ballots move to a final absorbing state that reflects the ballot status and is used to evaluate election performance. The final states capture all possible final states the voter ballot can take on at the end of the process, and they are defined to be mutually exclusive.

The voter ballots can be counted (C) or not counted (NC) by the election officials. There are several reasons a ballot may not be counted, and not all result from attacks to the process. Some ballots are not counted simply because they arrive at the election office after the required date for processing (L), which is typically an election day.

In traditional VBM processes the only ballot states that are recorded are not counted and counted ballots, and all ballots are assumed to be unaltered (U). Some ballots can be altered (A) by masquerade attacks. Since an altered ballot may not be observable, altered ballots could be counted or not counted. Additionally, ballots may be lost, and all lost ballots are not counted and listed as not returned (NR).

Together, a ballot can be in one of the six following final ballot states at the end of the time horizon considered in the DTMC:

- **(C,U)**: Voter ballot is received on-time unaltered in-transit, accepted, and counted on election day.
- **(NC,U)**: Voter ballot arrives on-time and unaltered, however it is rejected as incomplete.
- **(NC,L)**: Voter ballot is returned and does not arrive at the election office by election day, designated late ballot.
- **(C,A)**: Voter ballot is maliciously altered, accepted, and counted on election day
- **(NC,A)**: Voter ballot is maliciously altered, however it is rejected and not counted on election day.
- **(NC,NR)**: Voter does not return the ballot, includes ballots lost in transit and ballots never delivered [38].

Note that the preferred ballot status is for ballots to reach the (C,U) state.

3.3 Attacks Layer

The attacks layer is comprised of active vulnerabilities to the VBM process. Vulnerabilities in the VBM system are documented in attack trees by the US Election Assistance Commission [32] and have been expanded upon since the 2020 General Election [22]. The terminal nodes of these attack trees represent “access” points to additional vulnerabilities within the process. For this reason, we model each of these terminal leaf nodes of the attack trees. Attack trees, a valuable tool in cybersecurity, help assess threats to a system [26]. They depict potential vulnerabilities and attacker paths in a Boolean logic tree structure, where the root node represents the ultimate goal of an attacker. Attack trees use a combination of Boolean AND(\times) and OR($+$) logic gates to trace paths from terminal attack nodes back to the root node. Figure 1 shows an example of an attack tree that visualizes two attacks corresponding to the malicious loss ($X13$) and accidental loss ($X14$) of a ballot. In Figure 1, terminal attack nodes $X13$ and $X14$ form part of an attack path leading to

a successful insider attack, represented by root node 1 with only OR-gates along the paths. These attack paths offer a static view of threats within the VBM process, with the terminal leaf nodes X_{13} and X_{14} serving as entry points.

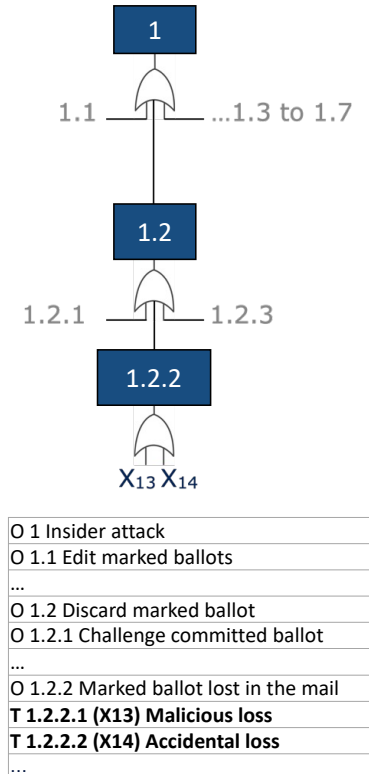

Figure 1: Example of a portion of the VBM attack tree

Haseltine et al. [8] explore the impact of attacks on the VBM process, focusing on how each attack could affect voter ballots in terms of being lost, late, or maliciously altered. Expanding upon this, here we classify attacks not only based on their impact on ballots but also on the VBM process as a whole. Terminal attack nodes are classified into three categories: *fail rate increase*, where attacks change the probability associated with an undesirable outcome; *ballot altering*, which involves direct tampering with the voter ballot; and *process-altering*, where attacks cause voter ballots to deviate from the standard physical VBM process. This broader perspective allows for a more comprehensive understanding of the attacks' implications.

Any attack that affects the probability associated with an outcome, e.g., a transition probability in the DTMC model, is considered to be a *fail-rate* increase. These attacks can be non-malicious, e.g., caused by voter errors when filling out a ballot. As a result, the election office has a higher rejection rate for returned ballots, resulting in uncounted votes. However, these attacks can also be malicious, e.g., caused by a bad actor at the election office erroneously failing ballots. For example, consider a malicious insider attack (X_9) in which a VBM ballot is erroneously deemed insufficiently filled out (errant failed signature). If the malicious attack occurs, it increases the probability that a completed ballot is rejected.

Changing the vote on a marked ballot alters the information in the original ballot we consider a “ballot-altering attack.” Masquerade attacks involve a bad actor maliciously altering a ballot. These attacks are more complex in that they create alternate ballot states in the DTMC that are needed to reflect the ballot’s change in composition. For example, a masquerade attack in which a bad actor votes on behalf of someone in a central housing situation requires several steps. The malicious actor must first register to vote on behalf of the original voter, intercept their mail, mark the ballot, and return the altered ballot to the VBM process. We designated this type of attack as ballot modifying. It is important to note that modified ballots still have the potential to be counted. For this reason, there is an alternate path for the modified ballots in the DTMC. This is later illustrated in the DTMC model attack layer in Section 4, which reflects the VBM process states in the process layer to indicate that the ballots of those states were maliciously altered during transit.

In the VBM system, there are seven distinct states that an original ballot must pass through to be counted and remain unaltered (see Section 3.1). When someone attempts to disrupt this process, it is known as a *process-altering* attack. For example, suppose an election volunteer steals the marked ballot while it is in transit to the election office. This malicious attack alters the ballot process by holding the ballot in an “attack state” outside of the normal stages of the election process until the voter is notified and uses a recourse action such as requesting a replacement ballot, or it is deemed not returned and is not counted. The notable implication of process-altering attacks is that they can delay or prevent ballots from reaching the election office.

Table 1 presents the list of terminal attack nodes to the VBM system from Scala et al. [22]. We focus on those attacks that require voter or election office recourse actions to be countered. The first column lists the updated terminal attack nodes in the VBM attack tree, while the second column identifies the specific stage in the VBM process affected by each attack. The third column indicates the final state of the ballot if the attack is successful. Table 1 delineates the intent and classification of each terminal node attack in the last two columns, offering insights into the nature of these threats. Table 1 boldface rows are considered the most significant risks to VBM. These attacks are considered significant attacks, since they introduce substantial variations in the final ballot states, thereby highlighting the relevance to our analysis.

There are malicious and non-malicious attack types. Malicious attacks are targeted and have a high local impact for a limited period of time (e.g., a day) of being active. Conversely, non-malicious attacks (e.g., voter error and accidental loss) are accidental and could occur any time in the DTMC model time horizon. For example, in the 2020 General Election, some ballots were not counted due to voters failing to sign or bundle the ballots correctly (attack *X67*). This non-malicious attack results in ballots being rejected by the election office, thus inhibiting the VBM process if not countered. We express this attack as a small probability of occurrence for each ballot over the entire evaluation period.

Table 1: Modeled VBM terminal attack nodes and their attributes

Attack tree	Terminal attack node	Final ballot state		Intent	Classification
	linkage to Process Layer	for successful attack			
T 1.2.1.1.1 (X8) Judge misinterprets rule	VII		NC, U	Malicious	Fail rate increase
T 1.2.1.1.2 (X9) Errant failed signature	VII		NC, U	Malicious	Fail rate increase
T 1.2.1.2.1 (X10) Challenge signature	VII		NC, U	Malicious	Fail rate increase
T 1.2.1.2.2 (X11) Challenge postmark	VII		NC, U	Malicious	Fail rate increase
T 1.2.1.2.3 (X12) Challenge intent	VII		NC, U	Malicious	Fail rate increase
T 1.2.2.1 (X13) Malicious loss	VI		NC, NR	Malicious	Process altering
T 1.2.2.2 (X14) Accidental loss	VI		NC, NR	Non-malicious	Process altering
T 1.5.1.1 (X28) Fail to stuff envelope	II		NC,A	Malicious	Ballot modifying
T 1.5.1.2 (X29) Send wrong or pre marked ballot	II		C,A	Malicious	Ballot modifying
T 1.5.1.3 (X30) Mis-address envelope (to voter)	II		NC,NR	Non-malicious	Process altering
T 1.5.3.1 (X36) accidentally lost in the mail room	VII		NC, NR	Non-malicious	Process altering
T 1.5.3.2 (X37) Mailbox attack	VI		NC, NR	Malicious	Process altering
T 1.7.2 (X84) Vote denied	VII		NC,U	Malicious	Process altering
T 2.3.1 (X43) Identify target residents	IV		C,A	Malicious	Ballot modifying
T 2.3.2 (X44) Register them	IV		C,A	Malicious	Ballot modifying
T 2.3.3 (X45) Intercept, mark, and return their ballot	IV		C,A	Malicious	Ballot modifying
T 2.3.4.1 (X46) Register as the voter	IV		C,A	Malicious	Ballot modifying
T 2.3.4.2 (X47) Forge the signature	IV		C,A	Malicious	Ballot modifying
T 2.4.1 (X48) Identify target	IV		C,A	Malicious	Ballot modifying
T 2.4.2 (X49) Steal blank ballot from mailbox	IV		C,A	Malicious	Ballot modifying
T 2.4.3 (X50) Receive, mark, return their ballots	IV		C,A	Malicious	Ballot modifying
T 2.4.4.1 (X51) Register as the voter	IV		C,A	Malicious	Ballot modifying
T 2.4.4.2 (X52) Forge the signature	IV		C,A	Malicious	Ballot modifying
T 2.5 (X53) Malicious "messenger ballots"	II		C,A	Malicious	Ballot modifying
T 2.8.1 (X93) Steal blank ballot from mailbox	IV		C,A	Malicious	Ballot modifying
T 2.8.2 (X94) Mark and return their ballot	IV		C,A	Malicious	Ballot modifying
T 2.8.3 (X95) Defeat signature check	IV		C,A	Malicious	Ballot modifying
T 4.1.1 (X65) Failure to sign correctly	IV		NC,U	Non-malicious	Process altering
T 4.1.2 (X66) Signature mismatch	IV		NC,U	Non-malicious	Process altering
T 4.1.3 (X67) Failure to bundle correctly	IV		NC,U	Non-malicious	Process altering
T 4.1.4 (X68) Failure to meet time requirements	IV		NC, L	Non-malicious	Process altering

3.4 Mitigations Layer

The mitigations layer in the DTMC model incorporates processes and actions designed to counteract both malicious and non-malicious threats. A mitigation is a recourse action available to counter any attacks to ballots in the VBM process. We build on previously published models of VBM mitigations to identify those that counteract attacks on the VBM process [8].

The mitigation layer connects with both the process and attack layers. We model structural mitigations both the physical pathways (arcs) and the probabilities (transitions) of a ballot’s progression. These require specific responsive measures from voters to negate the effects of attacks. The DTMC model consists of five structural mitigations $M3, M4, M5, M6, M7$; Table 2 details each mitigation. We derived these mitigations from prior work that condense countermeasures published by CISA into practical logic intertwined with the VBM process [8, 5]. Table 2 presents these mitigations, categorized according to their operational nature along with the controlling entity, election office or voter.

This paper necessitates a thorough understanding of the connections between terminal node attacks in the VBM process and the available mitigation strategies designed to counteract them. To facilitate this, we employ a framework that examines the impact of terminal node attacks on the VBM process and incorporates recourse actions available to counter these attacks. Table 3 illustrates the relationship between attacks and mitigations. In this table, an “O” indicates that

Table 2: Mitigations available for the VBM process

Label	Mitigation description	Controlling entity
M3	The ability of a voter to attain the status of their ballot. This has a high probability if automatic notifications are provided via BalloTrax/Ballot Scout.	Election office
M4	Replacement ballot package request	Voter
M5	Notify voter to send ballot back before deadline	Election office
M6	In-person absentee voting	Voter
M7	Return ballot via drop box	Voter

a mitigation strategy can counter the threat without impacting the ballot processing time. In contrast, a “D” signifies that while mitigation can counter the threat, it introduces a delay in the VBM process. For example, the scenario of a lost ballot (*X13*), a type of malicious attack, causes a delay resulting from the mitigation logic that includes the time required to notify the voter about their missing ballot followed by the time it takes for the voter to decide on an appropriate recourse action, such as *M4* or *M6*. This scenario exemplifies how Table 3 summarizes key linkages in the DTMC model introduced in the next section. Consistent with the attacks in Table 1, terminal attack nodes listed in bold are incorporated into the DTMC model and are included in the computational results.

Table 3: Linkages between terminal attack nodes and mitigations

Terminal Attack Nodes of VBM Attack Tree	M3 Automated notification of ballot status	M4 Replacement ballot voter request	M5 Notify voters to send ballot back earlier	M6 In-person absentee voting	M7 Return ballot via drop boxes
T 1.2.1.1.1 (X8) Judge misinterprets rule	D	D		D	
T 1.2.1.1.2 (X9) Errant failed signature	D	D		D	
T 1.2.1.2.1 (X10) Challenge signature	D	D		D	
T 1.2.1.2.2 (X11) Challenge postmark	D	D		D	
T 1.2.1.2.3 (X12) Challenge intent	D	D		D	
T 1.2.2.1 (X13) Malicious loss	D	D		O	O
T 1.2.2.2 (X14) Accidental loss	D	D		O	O
T 1.5.1.1 (X28) Fail to stuff envelope		D			
T 1.5.1.2 (X29) Send wrong or pre marked ballot	D	D			
T 1.5.1.3 (X30) Mis-address envelope (to voter)	D	D		O	
T 1.5.3.1 (X36) accidentally lost in the mailroom					
T 1.5.3.2 (X37) Mailbox \ Dropbox attack	D	D		O	
T 1.7.2 (X84) Vote denied	D	D			
T 2.3.1 (X43) Identify target residents	D	D			
T 2.3.2 (X44) Register them	D	D			
T 2.3.3 (X45) Intercept, mark, and return their ballot	D	D			
T 2.3.4.1 (X46) Register as the voter	D	D			
T 2.3.4.2 (X47) Forge the signature	D	D			
T 2.4.1 (X48) Identify target	D	D		O	
T 2.4.2 (X49) Steal blank ballot from mailbox	D	D		O	
T 2.4.3 (X50) Receive, mark, return their ballots	D	D		O	
T 2.4.4.1 (X51) Register as the voter	D	D			
T 2.4.4.2 (X52) Forge the signature	D	D			
T 2.5 (X53) Malicious “messenger ballots”	D	D			
T 2.8.1 (X93) Steal blank ballot from mailbox	D	D			
T 2.8.2 (X94) Mark and return their ballot	D	D			
T 2.8.3 (X95) Defeat signature check	D	D			
T 4.1.1 (X65) Failure to sign correctly	D	D			
T 4.1.2 (X66) Signature mismatch	D	D			
T 4.1.3 (X67) Failure to bundle correctly	D	D			
T 4.1.4 (X68) Failure to meet time requirements			O	O	

4 DTMC Model

In this section, we introduce a DTMC model of the VBM system based on a multi-layer configuration of the process, attacks, and mitigations layers. The DTMC model captures the stochastic movement of ballots through various stages from a ballot request to the counting of ballots. This approach allows us to analyze how different factors influence overall election performance. A crucial aspect of the DTMC model is its ability to delineate the interaction between the terminal attack nodes, the mitigation layer, and the VBM process.

The time-inhomogeneous DTMC operates over a finite time horizon starting at time step $t = 1$ and continues until the final time step T . The time between time steps is one day, with the state reflecting the system’s state at the end of day t . Let $t = 1$ capture the earliest time election officials process requests for absentee ballots. The election is held at time step $T - 1$, under the assumption that ballots are not accepted after an election day. The model can easily be adapted to consider accepting ballots postmarked by election day by adding extra time steps.

On election day, there are transition probability arcs re-positioned to move a ballot to its final post-election status in the last period, $t = T$, to evaluate the performance measures. Given a random process V_t with n finite states, the one-step transition probability of the process moving from state i in time step t to state j in a single time step is

$$P_t(i, j) = P(V_{t+1} = j | V_t = i) \quad \forall i, j \in \{1, \dots, n\}. \quad (1)$$

We define a transition probability matrix P_t for each time step ($t = 1, 2, \dots, T - 1$) to calculate the ballot states at the end of each time step [27]. Figure 2 illustrates the DTMC model state diagram for $t < T - 1$, showing the final ballot states along with three distinct layers: the process layer, the attack layer, and the mitigation layer. The DTMC model comprises 30 finite states $S \in V_t$, categorized into six recurrent final ballot states and 24 transient states. Next, we describe the DTMC states and transition probabilities, starting with the process layer and then adding the attack and mitigation layers.

The voting process initiates in the “I” state within the process layer, where voters begin the process by requesting a ballot. The ballot then navigates through various states in the process layer until it reaches one of the final ballot states. Table 1 details the interactions and connections between these states in the VBM process layer and the attacks layer. In Figure 2, different shapes represent distinct Markov states of the VBM system. Triangles depict attacks while circles depict the physical states of the ballots. Triangles labeled in black denote malicious attacks, whereas those in gold represent non-malicious attacks. When an attack is active, ballots transition from the process layer state to one of the triangular attack states. The “mitigations layer” encompasses recourse actions to counter attacks. Both $M5$ and $M7$ are illustrated in the process layer as these are *process-altering* mitigations. Mitigation $M5$ affects the rate of ballot returns from voters, and $M7$ enables voters to return their ballot in a drop box.

Additionally, Figure 2 uses line styles to convey information about the arc transition probabili-

ties in the DTMC. Solid lines indicate transitions with non-zero probabilities at all steps, except at the final time step $T - 1$. In contrast, dotted and dashed lines represent transitions with non-zero probabilities only at specific time steps, such as those associated with transient malicious attacks. The complexity of the model leads to overlapping lines in the figure; intersections marked by a dot signal a connection to the intersecting line. In the model, masquerade attacks change a ballot's status and add a hidden attribute. Process layer states are mirrored in the attacks layer and labeled with an 'A' in Figure 2 to indicate the altered status of these ballots. The DTMC model allows

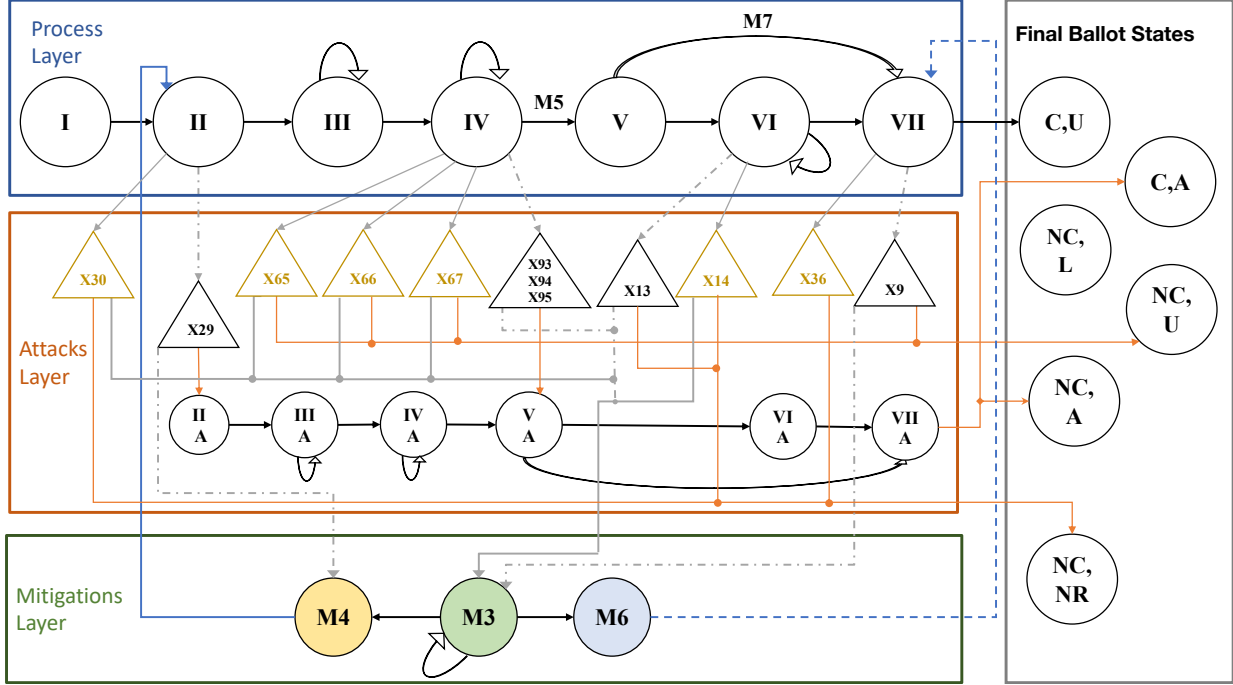

Figure 2: Layered Network for time intervals $1 \leq t < T - 1$

us to study VBM system performance as reflected by the final states of ballots over the course of an election cycle. We can determine the number of ballots that end up in the final desired state of “Counted, Unaltered” (C, U) and the other final ballot states.

At the end of the time horizon, the ballots move to the final ballot states. Figure 3 shows the non-zero transition probabilities on election day at time step $T - 1$. If ballots are not returned to the election office, they are “not counted, not returned” (NC, NR). These six final ballot states are recurrent in the DTMC, and all others are transient. If ballots are returned to the election office at $t = T$ they are “not returned, late”(NC, L).

Next, we summarize the transitions. Let P_t capture the transition probability matrix immediately after the time steps $t = 1, 2, \dots, T - 1$. Voters can request ballots at different times. Let β_t capture the number of ballots requested at time $t = 1, 2, \dots, T - 1$, which reflects the distribution of times when voters request absentee ballots. For the ballots requested at time t , let α_t be the vector of the probability mass function for the starting states of the ballot, where all the ballots

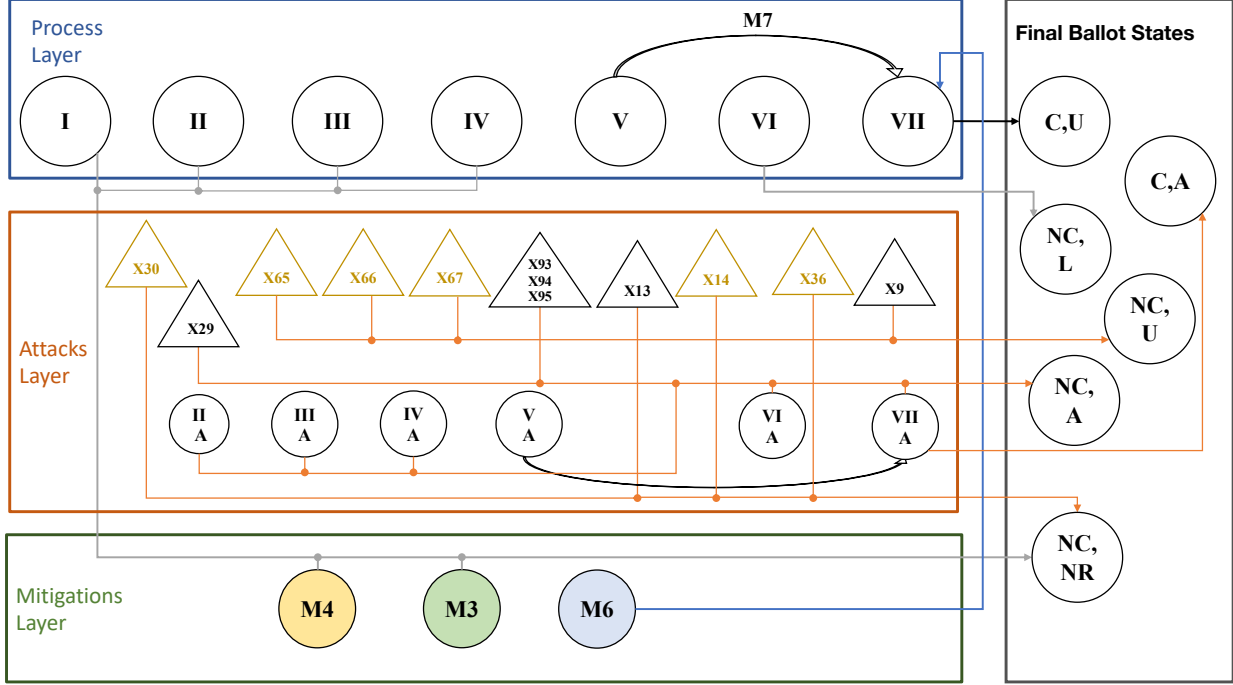

Figure 3: Layered Network for VBM on Election Day at time interval $t \geq T - 1$

are initiated in state I , that is, $\alpha_t(I) = 1$ and $\alpha_t(s) \geq 0$ for all other states $s \neq I$. For a ballot requested at time t , we can compute the vector of state probabilities at the end of the time horizon ω_t at time step T after all ballots have been evaluated and transitioned to one of the ballot status states:

$$\omega_t = \alpha_t \prod_{t'=t}^{T-1} P_{t'}, t = 1, 2, \dots, T - 1. \quad (2)$$

Then, we can compute the overall distribution of final ballot statuses as $\sum_{t=1}^{T-1} \beta_t \omega_t$ that reflects the expected number of ballots in each final ballot state.

5 Wisconsin 2020 General Election Case Study

We conduct a case study based on data from the 2020 General Election in Milwaukee County, Wisconsin. In 2020 Milwaukee County, the largest county in Wisconsin, had 939,489 residents and 478 voting wards [31, 4, 14]. Milwaukee County election officials used multiple absentee voting mechanisms during the 2020 General Election, including VBM with designated drop boxes and in-person absentee voting. The state of Wisconsin allowed absentee voting with “no excuses” and sent voter reminders to return ballots [16]. At that time, the county had 550,132 registered voters and experienced a turnout of 83.67 percent [36].

We assembled a data set for Milwaukee County using detailed, publicly reported information regarding absentee voting rates [37, 13]. The Wisconsin Elections Commission reports a daily tally

of the following events for each county prior to the election [33]:

1. absentee ballot requests,
2. ballots mailed out by an election office,
3. absentee ballots returned by mail, and
4. in-person absentee ballots cast.

Using this data, we determined the daily number of absentee ballots requested, β_t , for $t = 1, 2, \dots, T - 1$, with 94.1 percent of these ballots being returned. The procedures and recourse actions available to voters during the General Election on November 3, 2020 are represented in Table 2 as mitigations. All requested ballots correspond to the starting state of the DTMC state I . Additional data were obtained from the MIT Election Data + Science Lab and the United States Office of the Inspector General [15, 18]. The case study begins with establishing transition probabilities for each arc in the process for every time interval $t = 1, 2, \dots, T$ in the DTMC model.

5.1 Time

In the VBM process, ballot states of the DTMC model transitions on a daily basis. The case study begins on September 17, 2020 ($t = 1$), the first day ballots are mailed to voters, and ends after election day, November 4, 2020 ($T = 49$). The DTMC transition probabilities are time-dependent in accounting for procedure changes over the VBM timeline. For example, some mitigations are not available at all times due to VBM procedure, and malicious attacks occur at various times. However, many of the transition probabilities are homogeneous across time intervals. As a result, we partition the time horizon into four segments with transition probabilities that are time-homogeneous within an interval.

In the first interval, absentee voting opens and ballots are mailed to voters. The second interval begins when in-person absentee voting opens for the election. To reflect this procedure, mitigation $M6$ (related to in-person absentee voting) is unavailable during the first time interval. In the third time interval, ballots are no longer mailed to voters requesting absentee voting. During this interval, there is no longer a connection between the process states I and II . Instead, the connection from state I changes to $M6$, indicating that voters can only vote in-person absentee during this period. The fourth-time interval is election day and the days following, during which ballots are processed. Ballots that have not reached the USPS or the election office by election day are not counted. The exact final destination of the ballots depends on their location on election day. The model configuration in Figure 3 outlines all arc connections from the voter requesting a ballot, I of the process layer to one of the “final ballot states.” In summary, the case study defines the time intervals as follows:

- interval 1 starts on September 17, 2020 ($t = 1$ to $t = 34$),
- interval 2 starts on October 21, 2020 ($t = 35$ to $t = 42$),

- interval 3 starts on October 29, 2020 ($t = 43$ to $t = 47$), and
- interval 4 starts on November 3, 2020 ($t = 48$ to $t = 49$).

5.2 Transition probabilities

We define the transition probability matrices as follows. We first define the transition probabilities for the *baseline model* that only considers non-malicious attacks. Non-malicious attacks are represented as consistent threats with time-inhomogenous probabilities of occurrence. Later, we consider malicious attacks with a duration of one day.

Table 4 outlines the transition probabilities for each arc active in the baseline model. The first and second columns define the two DTMC states associated with a non-zero transition probability. The next column provides a brief functional description of the ballot state transition that the arc represents. The columns labeled Interval 1, 2 and 3 represent the values of associated transition probability across time intervals 1, 2, and 3. We omit interval 4, since these transition probabilities are 0 or 1 with arcs illustrated in Figure 3. The justification column reports a reference for each transition probability value and denotes which arcs were adjusted through calibration. The arc configuration aligns with the model shown in Figure 2.

We discuss several transition probabilities. The transition probability from process state *III* to *IV* is 0.938, which reflects the proportion of election mail that is processed on-time as reported by the USPS Inspector General [19]. The rest of the ballots remain in state *III*. The transition from state *IV* to *V* reflects the return of completed ballots by voters (that is, the voter rate of ballot return). This transition captures the proportion of voters who return the marked ballot within a day of receiving it in the mail, which is determined as a part of the model calibration since this value is not directly recorded. MIT Election Data + Science Lab [15] provide the values for utilization of drop boxes over USPS to return ballots. Transitions from state *V* to state *VII*, which occur with a probability of 0.515, represents the proportion of ballots returned by drop boxes. [15] Transitions at the end of the time interval move ballots to their final ballot states with probability 1.0. These probabilities can be gleaned from Figure 3. All other transition probabilities are zero. We calibrated the DTMC using historical data from the WEC 2020 General Election report [38]. This involved adjusting the voter rate of ballot return, the arc probability from node *IV* to *V*, to align the output of (C,U) and (NC,U) ballots with the observed ballot return rate seen in aggregate by the state of Wisconsin. Following calibration, we validate the model’s predictive accuracy by testing it against independent data validation points for Milwaukee County. This ensures blind prediction input data such that our model fits historical data and ensures the model is capable of making accurate predictions in varying scenarios.

Table 4: Arc transition probabilities

From node	To node	Function	Interval 1	Interval 2	Interval 3	Justification
I	II	Voter requests ballot to election office	1	1	1	All voter requests show being received by election office
II	III	Unmarked ballot sent from election office	1	0.2	0	All ballot requests filled by the election office
II	M6	Ballots requests are deferred to in-person absentee	0	0.8	1	WI policy for 2020 General Election [33]
II	X30	Ballot envelope mis-addressed to voter (undelivered)	0.0343	0.0343	0.0343	Calibration, Wisconsin Elections Commission [38]
III	IV	Unmarked ballot in transit via USPS	0.938	0.938	0.938	Office of Office of Inspector General [18]
III	III	Unmarked ballot remains at USPS past one cycle	0.062	0.062	0.062	Office of Office of Inspector General [18]
IV	IV	Voter waits one day to return ballot	0.947	0.797	0.947	Calibration, Wisconsin Elections Commission [38]
IV	V	Voter returns marked ballot	0.05	0.79	0.79	Calibration, Wisconsin Elections Commission [38]
IV	X65+X66+X67	Ballot subject to non-malicious attack of voter error voter error	0.000162	0.000162	0.000162	Calibration, Wisconsin Elections Commission [38]
V	VI	Marked ballot returned via USPS	0.485	0.485	0.485	MIT Election Data + Science Lab [15]
V	VII	Marked ballot returned via Dropbox	0.515	0.515	0.515	MIT Election Data + Science Lab [15]
VI	VII	Marked ballot in transit and received at election office	0.938	0.938	0.938	Office of Inspector General [18]
VI	X14	Marked ballot lost at USPS, non-malicious	0.0343	0.0343	0.0343	Calibration, Wisconsin Elections Commission [38]
VI	VI	Marked ballot remains at USPS past one cycle	0.061	0.061	0.061	Office of Office of Inspector General [18]
VII	(C,U)	Marked ballot processed at election office	0.966	0.966	0.966	Ballots are be counted and unaltered if not subject to attack
VII	X36	Marked ballot lost at election office, non-malicious	0.0343	0.0343	0.0343	Calibration, Wisconsin Elections Commission [38]
M4	II	Ballot replacement request	1	1	1	Once mitigation is reached, request are be made to election office
M3	M4	Voter is notified ballot has problem and chooses replacement	0.5	0.33	0.33	Equal probability for active mitigations
M3	M6	Voter is notified ballot has problem and chooses in-person vote	0	0.33	0.33	Equal probability for active mitigations
M3	M3	Voter is notified ballot has problem and chooses no recourse action	0.5	0.34	0.34	Equal probability for active mitigations
M6	VII	In-person absentee voting	1	1	1	Ballot successfully submitted
II-A	III-A	Modified ballot sent to the voter	1	1	1	WI timeline for absentee voting [34]
III-A	IV-A	Modified ballot received by the voter	0.9	0.9	0.9	Altered ballot received by the voter
III-A	III-A	Modified ballot remains in transit beyond one cycle	0.1	0.1	0.1	Attacked ballots movement low
IV-A	IV-A	Modified ballot is not filled out in one cycle	0.1	0.1	0.1	Approximation (fast return for malicious intent)
IV-A	V-A	Modified ballot returned	0.9	0.9	0.9	Approximation (fast return for malicious intent)
V-A	VI-A	Modified ballot returned via USPS	0.485	0.485	0.485	MIT Election Data + Science Lab [15]
V-A	VII-A	Modified ballot returned via Dropbox	0.515	0.515	0.515	MIT Election Data + Science Lab [15]
VI-A	VII-A	Modified ballot returned to election office on-time	1	1	1	Office of Office of Inspector General [18]
VII-A	(C,A)	Modified ballot counted	0.5	0.5	0.5	Equal probability of being counted unless other mitigations are in place
VII-A	(NC,A)	Modified ballot rejected at election office	0.5	0.5	0.5	Equal probability of being counted unless other mitigations are in place
X14	M3	Voter notified of non-malicious attack of lost ballot	0.0265	0.0265	0.0265	Calibration, Wisconsin Elections Commission [38]
X14	(NC,NR)	Marked ballot lost in process	0.974	0.974	0.974	Inverse of M3 availability
X36	(NC, NR)	Ballot lost in election office	1	1	1	No monitoring available, no recourse
X65+X66+X67	M3	Voter made aware of errors in ballot package	0.0265	0.0265	0.0265	Calibration, Wisconsin Elections Commission [38]
X65/X67	(NC,A)	Marked ballot rejected at election office	0.974	0.974	0.974	Inverse of M3 availability
X93-X95	V-A	Masquerade attack leading altered ballot path	0.10	0.10	0.10	Test various strengths of attack on various days
X93-X95	M4	Mitigation M4 availability	0.90	0.90	0.90	Test various strengths of attack on various days
X9	(NC,A)	Malicious challenge of ballot signature successful	0.974	0.974	0.974	Test various strengths of attack on various days
X9	M3	Voter notified of failed ballot submission	0.0265	0.0265	0.0265	Calibration, Wisconsin Elections Commission [38]
X29	III-A	Malicious incomplete ballot sent to voter leading to altered ballot path	0.10	0.10	0.10	Test various strengths of attack on various days
X29	M4	Voter requests replacement ballot	0.90	0.90	0.90	Test various strengths of attack on various days

Table 5: Baseline values for mitigation deployment level

Mitigation	Mitigation strength	Justification
M3	0.0265	Automatic voter notifications of ballot status were not implemented
M4	0.900	Voters had option of requesting replacement ballots
M5	0.740	Region used ballot return reminders
M6	0.400	In-person absentee was implemented
M7	0.520	Survey of the Performance of American Elections Dataverse [3]

5.3 Calibration

We calibrated the model using Wisconsin state-level data to align the recorded values of the ballots returned on various days with the calculated number of ballots counted and unaltered (C, U) final ballot state of the DTMC model. To accomplish this, we set the *voter rate of ballot return* to reflect the influence of mitigation $M5$ (reminders); the arc transition probability from node IV to node V reflects the voter rate of ballots to return in intervals 2 and 3.

Figure 4 illustrates the cumulative number of ballots returned by day (solid line) compared to the expected number of ballots returned in the DTMC model (dotted line) using the calibrated return rates. The comparison of actual and modeled returned ballots for Milwaukee County is aligned with actual daily ballots returned (blue) and the baseline of the DTMC model for daily ballots returned (dashed). Note that all mitigations are not active in all time intervals. For example, the mitigation $M5$ for reminders to return ballots was not implemented until time $t = 35$ (interval 2). Figure 4 shows that the modeled baseline model aligns closely with real-world data.

We then consider the mitigations of the model to determine a starting point for policies active in the 2020 Wisconsin General Election. We study the availability of mitigations $M3$, $M4$, $M5$, $M6$, and $M7$. Mitigation strength refers to the effect of each mitigation on the magnitude of the associated arc transition probabilities. Table 5 lists the inputs associated with mitigation strength in the baseline model. Low strength (less than 0.05) is associated with a minimal impact of that mitigation on the VBM system. Wisconsin voters were able to view ballot notifications manually through myvote.wi.gov, Wisconsin did not implement automatic ballot notification in 2020, so this value is low to reflect that few voters manually checked their ballot statuses. We set mitigation $M3$ strength to 0.0265, which resulted in a mean absolute deviation of 0.24-percent from the observed number of (NC, U) ballots. Next, we set mitigation $M4$ to 0.90 to represent the ability of voters to request replacement ballots. We set mitigation $M5$ to 0.74 to represent the sent and advertised reminders to return ballots in the late second interval. In Table 4 we see the arc from node IV to node V increases in interval 2 to account for the increased rate of ballot return caused by implementation of mitigation $M5$. Next, we set mitigation $M6$ to 0.40 to represent the rate voters choose to submit an absentee ballot in person. Finally, we set the strength of $M7$ to the average

Table 6: Model validation using WI Election Commission (WEC) data

Validation point	WEC ballot status	Corresponding DTMC final ballot states	WEC ballot counts	WEC ballot counts scaled to Milwaukee County	DTMC ballot counts
v1	Ballots returned and counted	(C,U)+(C,A)	1,969,274	324,896	324,792
v2	Ballots not returned	(NC, NR)	85,586	20,349	20,371
v3	Ballot rejected by election office	(NC,U)+(NC,A)	3,225	532	559
v4	Ballot not returned before polls closed	(NC,Late)	1,045	176	173
v5	All sent ballots	County specific sum of all ballot states	2,059,130	325,547	325,351

use in the state of Wisconsin [15]. This results in a mean absolute deviation of 0.25-percent from the observed number of (NC,U) ballots.

The calibration of the baseline DTMC model also requires consideration of non-malicious attacks; we model as part of normal system operations. The *ballot rejection rate* of the model is associated with the arc transition probability from node *IV* to $(X65 + X67 + X68)$. It correlates directly with the number of ballots rejected by the election office due to voter error. We set the ballot rejection rate to 0.000162 to closely match the observed number of returned ballots that were unaltered and not counted (NC,U). Next, we vary the impact of the remaining non-malicious attacks, representing the ballots that never returned to the election office. Recall terminal attack node *X14* represents the accidental loss of ballots in the mail. The terminal attack node *X30* is the misaddressing of ballots to the voter, and *X36* represents the accidental loss of ballots in the election office. These non-malicious attacks all result in the same penalty, and the ballots impacted are considered not counted and not returned (NC,NR). Unlike the ballot rejection rate of the election office, there is a lack of evidence to support the different magnitudes for the non-malicious attacks *X14*, *X30*, *X36*. These non-malicious attack strength values are equivalent for all periods $t = 1, \dots, T - 1$ [35]. Therefore, we set the terminal attacks *X14*, *X30*, *X36* to equal strength. As a result, the following arcs have the same transition probability of 0.0343: arc from *IV* to *X14*; arc from *II* to *X30*; arc from *VII* to *X36*. These arcs result in a mean absolute deviation of 0.14-percent from the observed (C,U) ballots.

5.4 Validation

To validate the DTMC, we align the model outputs with five validation points from the 2020 WEC report scaled to Milwaukee County by ratio of ballots returned [38]. The validation points are as follows:

- **v1:** Captures all returned and counted ballots. WEC reports these values for Milwaukee County on each day of the election cycle.
- **v2:** Captures all ballots sent and not returned to the election office. WEC reports these values for Milwaukee County on each day of the election cycle.
- **v3:** Reflects the ballots returned to the election office and rejected due to non-malicious attacks (*X65*, *X66*, *X67*). WEC reports the state level for the rejection rate of ballots; population ratios are used to scale to Milwaukee County.

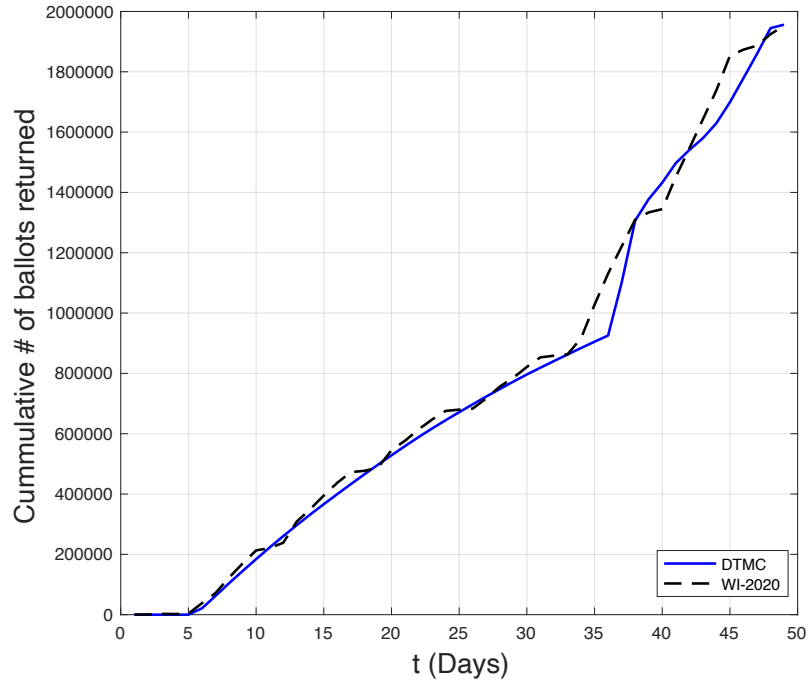

Figure 4: Comparison of recorded and modeled returned ballots for the state of Wisconsin for the 2020 General Election. The graph shows daily ballots returned in blue and the DTMC model baseline for daily ballots returned as a dashed line.

- **v4:** Reflects all ballots deemed late as of day 48 of the election cycle. Again, WEC reports the state level for late ballots; population ratios are used to scale for Milwaukee County.
- **v5:** Captures the sum of all sent ballots. WEC reports these values for Milwaukee County on each day of the election cycle.

Table 6 summarizes the validation points and relates them to the final ballot states of the model. The last two columns of Table 6 show the number of ballots under each validation point, comparing real world ballot counts “WEC ballot counts scaled to Milwaukee” and the DTMC model ballot counts. The validation process, aligning the DTMC model with real-world data from the WEC report, reinforces the model’s reliability in reflecting absentee voting behaviors and provides valuable insights into vote-by-mail dynamics in Wisconsin. The last column of Table 6 shows the DTMC model output values for the given validation points. Comparative analysis aligned the model’s final ballot states with the WEC report’s metrics. Once calibrated and validated the model, most transition probabilities were established for all time intervals. Milwaukee County data points are then used to establish a baseline model that can be used to consider multiple scenarios.

Table 7: Baseline DTMC model values and final ballot states

Scenario	Election office rejection rate	X_{14}, X_{30}, X_{36} attack strength	Final Ballot States (Expected number of ballots)					
			(C,U)	(NC,U)	(C,A)	(NC,L)	(NC,NR)	(NC,A)
Baseline	0.000162	0.0343	324,792	559	0	173	20,371	0
Baseline that varies election office rejection rate from node IV to $(X_{65} + X_{67} + X_{68})$	0.0000707	0.0343	325,091	245	0	174	20,386	0
	0.000111	0.0343	324,958	385	0	174	20,379	0
	0.000172	0.0343	324,759	594	0	173	20,369	0
	0.000424	0.0343	323,933	1,464	0	173	20,325	0
	0.000818	0.0343	322,653	2,812	0	172	20,258	0
Baseline that varies non-malicious attack strength associated with X_{14}, X_{30}, X_{36}	0.000162	0.00202	339,228	559	0	198	5,911	0
	0.000162	0.0192	331,493	559	0	184	13,660	0
	0.000162	0.0384	323,025	559	0	171	22,141	0
	0.000162	0.0576	314,732	560	0	158	30,445	0
	0.000162	0.0939	299,469	560	0	140	45,728	0

6 Computational Results

This section discusses the baseline DTMC model results for the Milwaukee County cawe study. We then study the impact of several types of malicious attacks on the established baseline. We report the expected number of ballots in each of the final ballot states—rounded to the nearest ballot—under multiple scenarios.

6.1 Baseline model

We first analyze the VBM system under normal conditions with non-malicious attacks in the baseline model introduced in Section 5. Non-malicious attacks (see Table 4) are included in the baseline model, since they are an uncontrolled, continuous part of the VBM process. Additionally, we perform a sensitivity analysis of four of the non-malicious attacks by varying their corresponding probabilities of occurring.

Table 7 summarizes the expected number of ballots in each final ballot state: counted and unaltered (C,U), not counted and unaltered (NC,U), correctly counted but altered (C,A), not counted due to late arrival (NC,L), not counted due to not being returned (NC,NR), and not counted and altered (NC,A). Table 7 also reports a sensitivity analysis that varies the election office rejection rate and three other non-malicious attack transition probabilities used in the model. The election office rejection rate varies based on ballots returned and rejected by the election office on election day due to non-malicious attacks X_{65}, X_{66} , and X_{67} , according to subject matter expert testimony [1]. The non-malicious attack strength of attacks X_{14}, X_{30} , and X_{36} represent ballots not returned due to either not being delivered to the voter or being discarded at the election office before counting the valid returned ballots on election day [38].

The top row of Table 7 represents the baseline model, and it reports the expected number of ballots in each final ballot state. Each subsequent row represents a different scenario with varying attack parameters. The incremental increase of the rejection rate associated with the arc transition probability from node IV to $(X_{65} + X_{67} + X_{68})$ by a probability of 0.00001 increases the number of (NC,U) ballots by 6-percent (35 total ballots), suggesting that efforts to reduce the rejection rate can decrease the number of ballots that are not counted. Higher attack strengths associated with X_{14}, X_{30}, X_{36} increase the number of ballots not returned (NC,NR). For example, when the

attach strength increases from 0.0343 to 0.0576, the number of (NC,NR) ballots increase by 10,074. Additionally, we note that the election office rejection rate ($X_{65}+X_{66}+X_{67}$) for Milwaukee County is substantially lower than that of the other non-malicious attacks. These insights underscore the need for additional attention to unreturned (NC,NR) ballots in the VBM process and maintaining minimal non-malicious attack strengths to ensure that ballots are returned and counted.

6.2 Malicious attack scenarios given baseline

Next, we consider introducing malicious attacks to the baseline. We focus on malicious attacks X_9 , X_{13} , and X_{29} . Malicious attacks are modeled to last a single day during the 49-day time horizon to reflect feasible real-world election interference events, and we vary the attack strength of each attack to consider different scenarios. Malicious attacks therefore, modify the transition probability matrix (P_{t^*}) for a single day associated with the attack t^* . This approach allows us to assess the impact of attack timings and the mitigation strategies for countering attacks.

6.2.1 X9: Malicious attack to challenge the signature of a valid ballot

Malicious X_9 attack captures bad actors in an election office erroneously rejecting marked ballots by challenging their signatures. This scenario, with a base arc transition probability of 0.055, is set to affect roughly one of 19 precincts in Milwaukee. Referencing Fig. 2, malicious attack X_9 impacts process state VII , where ballots are collected and verified by the election office. On a specific day, this could lead to a significant number of ballots being improperly discarded.

Table 8 details the impact of the X_9 attack, showing variations in the expected number of ballots across the final ballot states under varying attack strengths and days. The top section reports the scenario of a medium-strength attack on different days. The following four sections of Table 8 select a day in the interval and vary the attack strength. These comparisons show the impact of attack strength versus attack day. We pay particular attention to ballot state (NC,U), since attack X_9 causes ballots to not reach this state. Recall that there are 559 ballots in the (NC,U) final ballot state (see Table 7). Table 8 reports how the attack day and attack strength affects the ballot outcomes. In the top section we find Day 38 to be particularly critical, in that 2,415 ballots end in the (NC,U) final ballot state. This increase in affected ballots is caused by increased ballot inflow due to active mitigations M_5 and M_6 , initiated on day 36 (October 21, 2020). This finding underscores a vulnerability when attack strength is minimal but timed with peak ballot presence, highlighting critical periods when attacks have a larger scope of impact.

6.2.2 X13: Malicious attack discard ballot in transit via USPS

Malicious X_{13} attack represents bad actors in a postal office who discard completed ballots at the sorting or storage point. Referring back to Fig. 2, we see that malicious attack X_{13} directly impacts process state VI where the voter returns the completed ballot via USPS. In Milwaukee

Table 8: Attack X9: The malicious attack of erroneously rejecting of ballots

Scenario	Day of malicious attack	Malicious attack strength	Final Ballot States (Expected number of ballots)					
			(C,U)	(NC,U)	(C,A)	(NC,L)	(NC,NR)	(NC,A)
X9 active at medium strength varying attack days	10	0.055	324,341	933	0	173	20,449	0
	30	0.055	324,495	779	0	173	20,449	0
	36	0.055	324,524	751	0	173	20,449	0
	37	0.055	323,092	2,180	0	173	20,451	0
	38	0.055	322,857	2,415	0	173	20,451	0
	39	0.055	324,094	1,180	0	173	20,449	0
	40	0.055	324,286	988	0	173	20,449	0
	45	0.055	324,106	1,161	0	173	20,457	0
Vary attack strength X9 with attacks in interval 1	48	0.055	324,053	1,221	0	173	20,449	0
	10	0.050	324,375	899	0	173	20,449	0
	10	0.055	324,341	933	0	173	20,449	0
	10	0.075	324,205	1,069	0	173	20,450	0
	10	0.100	324,035	1,239	0	173	20,450	0
	30	0.050	324,515	759	0	173	20,449	0
	30	0.055	324,495	779	0	173	20,449	0
	30	0.075	324,415	859	0	173	20,449	0
Vary attack strength X9 with attacks in interval 2	30	0.100	324,315	959	0	173	20,449	0
	40	0.050	324,325	949	0	173	20,449	0
	40	0.055	324,286	988	0	173	20,449	0
	40	0.075	324,130	1,144	0	173	20,449	0
Vary attack strength X9 with attacks in interval 3	40	0.100	323,935	1,339	0	173	20,450	0
	45	0.050	324,161	1,106	0	173	20,456	0
	45	0.055	324,106	1,161	0	173	20,457	0
	45	0.075	323,884	1,380	0	173	20,460	0
Vary attack strength X9 with attacks in interval 4	45	0.100	323,607	1,653	0	173	20,464	0
	48	0.050	324,114	1,161	0	173	20,449	0
	48	0.055	324,053	1,221	0	173	20,449	0
	48	0.075	323,813	1,462	0	173	20,449	0
Vary attack strength X9 with attacks in interval 4	48	0.100	323,512	1,763	0	173	20,449	0

Table 9: Attack X13: Ballot maliciously discarded in transit via USPS

Scenario	Day of malicious attack	Malicious attack strength	Final Ballot States (Expected number of ballots)					
			(C,U)	(NC,U)	(C,A)	(NC,L)	(NC,NR)	(NC,A)
X13, are active at medium strength varying attack days	10	0.033	324,495	559	0	173	20,551	0
	36	0.033	324,602	559	0	173	20,502	0
	37	0.033	323,059	559	0	173	21,219	0
	38	0.033	324,300	559	0	173	20,642	0
	40	0.033	324,544	559	0	173	20,529	0
	45	0.033	324,649	559	0	173	20,480	0
Vary attack strength X13 with attacks in interval 1	10	0.025	324,521	559	0	173	20,525	0
	10	0.030	324,505	559	0	173	20,541	0
	10	0.040	324,473	559	0	173	20,574	0
	10	0.065	324,392	559	0	173	20,654	0
	30	0.025	324,601	559	0	173	20,494	0
	30	0.030	324,592	559	0	173	20,503	0
	30	0.040	324,573	559	0	173	20,522	0
	30	0.065	324,525	559	0	173	20,570	0
Vary attack strength X13 with attacks in interval 2	40	0.025	324,564	559	0	173	20,508	0
	40	0.030	324,551	559	0	173	20,521	0
	40	0.040	324,526	559	0	173	20,546	0
	40	0.065	324,464	559	0	173	20,609	0

Table 10: Attack X29: Intercept and pre-mark ballot to voter

Scenario	Day of malicious attack	Malicious attack strength	Final Ballot States (Expected number of ballots)					
			(C,U)	(NC,U)	(C,A)	(NC,L)	(NC,NR)	(NC,A)
X29 are active at medium strength varying attack days	7	0.055	324,086	558	332	173	20,416	332
	8	0.055	324,466	559	132	173	20,436	132
	10	0.055	324,495	559	116	173	20,437	116
	20	0.055	324,528	559	99	173	20,439	99
	30	0.055	324,573	559	75	173	20,441	75
	40	0.055	325,990	560	99	175	20,516	109
Vary attack strength X29 with attacks in interval 1	20	0.025	324,630	559	45	173	20,444	45
	20	0.050	324,545	559	90	173	20,440	90
	20	0.075	324,460	559	135	173	20,435	135
	20	0.100	324,375	559	180	173	20,431	180
	30	0.025	324,651	559	34	173	20,445	34
	30	0.050	324,586	559	68	173	20,442	68
	30	0.075	324,521	559	102	173	20,439	102
	30	0.100	324,457	559	136	173	20,435	136
Vary attack strength X29 with attacks in interval 2	40	0.025	326,097	560	45	175	20,522	50
	40	0.050	326,007	560	90	175	20,517	99
	40	0.075	325,918	560	134	174	20,512	149
	40	0.100	325,828	560	179	174	20,507	198

County, a large-scale attack affects one of the 36 USPS offices for a day [12]. Consequently, there is a probability of 0.033 that ballots in process state *VI* are impacted by the *X13* attack.

Table 9 summarizes the impact of attack *X13*, showing variations in the expected number of ballots across different final states under varying attack strengths and days. The top section reports the scenario of a medium strength attack on different days. The following two sections of Table 9 selects a day in the interval and varies the attack strength to determine the impact of attack strength versus attack day. Attack *X13* affects the number of ballots that are not returned, leading to an increase in the (NC,NR) final ballot state. The highest number of (NC,NR) ballots occurs when there is a malicious attack on day 37 of the election cycle. There are 21,219 ballots expected to not be returned (NC, NR), an 848 additional ballots not returned when compared to the baseline.

6.2.3 Masquerade Attacks, Ballot Modifying

We then consider malicious attack *X29*, which alters voters' original ballots, impacting process states *II*. The consequence of this attack leads to altered ballots that are both counted and uncounted (final ballot states (C,A) and (NC,A)). The arc probability strengths from attack *X9* are reflected here, since there exists no known reference of an executed masquerade attack.

We assume that there is an equal probability that the altered ballot are counted or uncounted. The analysis regarding attack *X29* underscores the vulnerability of the voting process to pre-altered ballot distributions. This manipulation targets the early stages of ballot circulation, redirecting ballots from the process layer state *II* to the attack layer state *II, A*.

Table 10 summarizes the results associated with various days and strengths of attack *X29*. The first column lists the scenarios considered, and the next two columns report the attack day and strength associated with different scenarios. The remaining columns report the expected number of ballots in each of the final ballot states. The final ballot states (C, U) and (C, A) reflect the impact of attack *X29*. Table 10 shows the variations in the intensity of the attack during two distinct intervals, namely intervals 1 and 2. Intervals 3 and 4 are not studied, since ballots are not mailed

to voters in these intervals. The attack day greatly affects the impact of the attack on the VBM process, affecting up to 664 ballots on a day 7 attack. Attacks carried out in the initial stages of the election have a large impact, since many ballots are mailed at these times.

Overall, these results reveals a clear trend: initiating an attack in a high-demand phase of the election cycle results in a higher number of affected ballots.

6.3 Worst-Case Scenario Modeling

We build on the attack scenarios in Section 6.2 to create a “worst-case scenario” to evaluate various policy implementations in the VBM process to severe conditions as well as the impact on mitigations. The worst-case scenario features the simultaneous execution of the following three malicious attacks within the election cycle: X_{13} on day 37, X_{29} on day 7, and X_9 on day 38. The following arc probabilities are all set to 0.10 on these days: arc from node IV to X_{13} on day 37; arc from node II to X_{29} on day 7; arc from node VII to X_9 . We also consider a sensitivity analysis that evaluates the impact of mitigation strength and associated strength against the worst-case attack scenario. Referencing Table 3 in Section 3.4, four mitigations counter the attacks in the worst-case scenario (see Table 3):

- X_9 is countered by $(M3, M4, M6)$ ¹
- X_{13} is countered by $(M3, M4, M6, M7)$ ²
- X_{29} is countered by $(M3, M4)$

Table 11 reports final ballot states associated with various mitigation scenarios, reflected by the first five columns. Then, it outlines the expected number of ballots in each final ballot state in the remaining six columns.

We first vary drop box availability ($M7$) from its base value of 0.520 using an availability range from 0.1 to 0.95. We do not consider $M7$ to have zero availability, since voters can return their absentee ballots directly to their local municipality election administration office. The remaining mitigations ($M6, M4, M3$) vary in availability, ranging from 0.01 to 0.95 to capture a wide range of operating conditions based on current federal laws and reports of mitigation effectiveness [2].

The first row of Table 11 shows the impact of the worst-case malicious attack scenario on the DTMC model for Milwaukee County. We see 8,950 fewer ballots counted and unaltered (C,U) than the baseline. Further, we see 1,208 altered ballots in final ballot states (C,A) and (NC,A). The number of ballots that are not counted increases significantly, with 3,593 (NC,U) ballots compared to 559 in the baseline. The results in Table 11 show a substantial impact in the performance of the VBM process when compared to the baseline results with no malicious attacks in Table 7. Next, we vary mitigation strength to find which mitigations might be effective in countering the affects of the

¹ $M3$: Automatic voter notification system, $M4$: Increased security measures, $M6$: In-person absentee voting

² $M7$ represents dropboxes available in the region

worst-case scenario. The goal is to align the worst-case with the baseline through only modifying mitigation strengths.

Next, we vary mitigation strength. Drop box $M7$ availability significantly impacts the number of ballots in the final ballot states. Increasing the availability of $M7$ to 0.95 increases the counted ballots (C,U) to 324,867, which is higher the 324,792 (C,U) ballots in the baseline scenario without malicious attacks. Reducing $M7$ availability to less than 0.10 results in 17,776 (NC,U) ballots, the highest across all worst-case scenarios. However, $M7$ does not counter masquerade attacks to reduce the number of altered ballots (C,A) or (NC,A).

The following eight rows in Table 11 examine the availability of mitigation $M6$ associated with in-person absentee. Changes in $M6$ availability has substantially less impact on final ballot states than mitigation $M7$ availability. Similar to $M7$, the availability of mitigation $M6$ fails to counter masquerade attacks by reducing the number of altered ballots (C,A) or (NC,A).

Next, we examine varying mitigations $M3$ and $M4$ simultaneously to reflect their interdependency. We find that deploying automatic ballot notifications ($M3$) with the same availability as $M4$, at 0.90, results in 325,584 counted (C,U) ballots, an increase of 9,742 ballots as compared to the baseline, worst-case performance in the first row of Table 11. An $M3$ availability of 0.90 results in 62 expected (C,A) ballots. Lastly, since $M3$ and $M6$ can function interdependently, we examine the impact of simultaneously varying $M3$ and $M6$. When deployed at 0.90 availability, we observe 325,485 (C,U) ballots, similar to the previous observations. Additionally, we observe fewer ballots not returned, with 17,243 (NC,NR) ballots compared with 20,371 (NC,NR) ballots in the Milwaukee baseline without malicious attacks. We conclude that in-person absentee voting gives voters a powerful recourse option to counter malicious and non-malicious attacks.

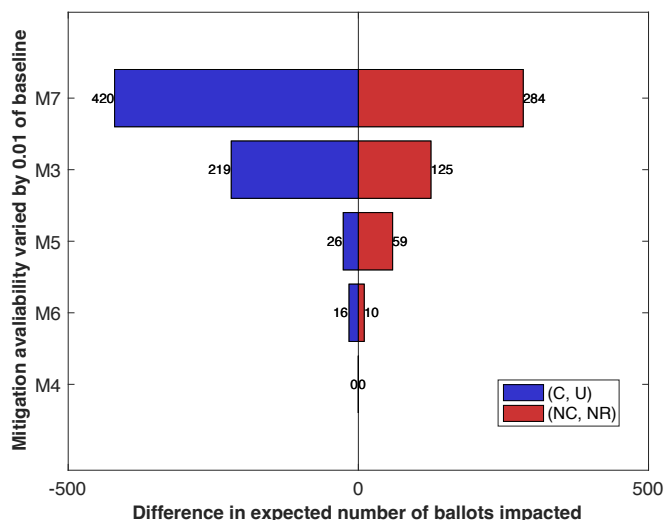

Figure 5: Results of a sensitivity analysis that evaluates the impact of mitigations $M3$, $M4$, $M5$, $M6$, and $M7$ on the DTMC model’s final ballot outputs in the presence of multiple malicious attacks. We compare the changes in the expected number of (C, U) and (NC, NR) ballots to the baseline.

Table 11: Policy performance for a worst-case election cycle

Scenario	M3 available	M4 available	M6 available	M7 available	Final Ballot States (Expected number of ballots)					
					(C,U)	(NC,U)	(C,A)	(NC,L)	(NC,NR)	(NC,A)
Milwaukee County baseline performance for worst case (X13, day 37) + (X29, day 7) + (X9, day 38)	0.027	0.900	0.400	0.520	315,842	3,593	604	391	22,913	604
Vary drop box M7 availability for worst case	0.027	0.900	0.400	0.100	307,016	4,865	604	735	28,901	604
	0.027	0.900	0.400	0.200	309,118	4,562	604	653	27,475	604
	0.027	0.900	0.400	0.520	315,842	3,593	604	391	22,913	604
	0.027	0.900	0.400	0.750	320,671	2,897	604	203	19,637	604
	0.027	0.900	0.400	0.850	322,769	2,594	604	122	18,213	604
	0.027	0.900	0.400	0.950	324,867	2,291	604	41	16,789	604
Vary in-person absentee M6 for worst case	0.027	0.900	0.010	0.520	316,160	3,198	604	423	23,099	604
	0.027	0.900	0.100	0.520	316,086	3,289	604	416	23,056	604
	0.027	0.900	0.200	0.520	316,005	3,390	604	407	23,009	604
	0.027	0.900	0.300	0.520	315,923	3,492	604	399	22,961	604
	0.027	0.900	0.400	0.520	315,842	3,593	604	391	22,913	604
	0.027	0.900	0.500	0.520	315,760	3,694	604	382	22,865	604
	0.027	0.900	0.750	0.520	315,557	3,948	604	362	22,745	604
	0.027	0.900	0.950	0.520	315,393	4,150	604	345	22,650	604
Vary Ballot Trax/Scout implementation M3 with mail-in availability M4	0.010	0.010	0.400	0.520	315,661	3,652	614	389	23,016	614
	0.027	0.027	0.400	0.520	315,842	3,593	604	391	22,913	604
	0.050	0.050	0.400	0.520	316,099	3,508	590	393	22,766	590
	0.400	0.400	0.400	0.520	319,963	2,236	372	423	20,558	372
	0.500	0.500	0.400	0.520	321,078	1,868	310	432	19,921	310
	0.600	0.600	0.400	0.520	322,197	1,499	248	441	19,281	248
	0.800	0.800	0.400	0.520	324,451	753	124	459	17,992	124
	0.900	0.900	0.400	0.520	325,584	378	62	468	17,344	62
	0.950	0.950	0.400	0.520	326,153	189	31	472	17,018	31
Vary Ballot Trax/Scout implementation M3 with in-person absentee availability M6	0.010	0.900	0.010	0.520	315,984	3,250	614	422	23,205	614
	0.027	0.900	0.027	0.520	316,146	3,214	604	422	23,092	604
	0.050	0.900	0.050	0.520	316,379	3,162	590	422	22,931	590
	0.400	0.900	0.400	0.520	319,963	2,236	372	423	20,558	372
	0.500	0.900	0.500	0.520	321,030	1,921	310	424	19,889	310
	0.600	0.900	0.600	0.520	322,115	1,582	248	426	19,222	248
	0.800	0.900	0.800	0.520	324,343	837	124	430	17,900	124
	0.900	0.900	0.900	0.520	325,485	430	62	433	17,243	62
	0.950	0.900	0.950	0.520	326,063	218	31	434	16,916	31

Next, we study the sensitivity of the DTMC model mitigation strength. The two final ballot states we study are the desired final ballot state (C,U) and the unreturned ballots (NC,NR) since these two final ballot states are the most impacted by mitigations. However, other ballot states are impacted by mitigations to a lesser degree. We perform a one-way sensitivity analysis by changing each mitigation strength by ± 0.01 from its baseline value (see Table 2). Figure 5 shows a tornado graph illustration of the results. The blue half of Fig. 5 on the left represents the difference in the number of correctly counted and unaltered ballots when the mitigation strength decreases. The red half is the difference in the number of ballots that are not counted and not returned, which occurs when mitigation strength increases. The tornado graph shows that the DTMC model is most sensitive to mitigations *M7* and *M3*. In contrast, mitigations *M4* and *M6* (independently) do not significantly affect the outputs in a significant manner. However, their impact can be larger when their availability is considered within the context of other mitigations (see Table 11).

7 Conclusions

VBM process and policy are rapidly evolving in the United States. Our research presents a quantitative tool designed to assess the risks and impacts of mitigations within VBM systems. We introduce a discrete-time Markov Chain modeling framework, which we apply to a case study

based on the 2020 General Election in Milwaukee County to evaluate the security and effectiveness of VBM processes. Our findings highlight the critical role of dynamic mathematical modeling in computational risk analysis for VBM systems. This layered approach effectively organizes the complex interactions among cyber, physical, and human elements in VBM, providing insight into VBM vulnerabilities. Our analysis, which leverages various ballot outcomes and real-world data, highlights the model’s ability to assess voting risks.

Singular mitigations, such as drop boxes, can bolster the VBM system, while other mitigations must be combined to reduce risk. A crucial observation is that mitigation $M3$ (dependent on $M4$ or $M6$) is the only mitigation capable of effectively countering ballot-altering malicious attacks. The variation of each mitigation policy set changes the VBM process’s resilience to the worst-case scenario. These changes mark quantifiable metrics for evaluating VBM security and highlight the need for an integrated and adaptive mitigation approach to ensure the integrity of the VBM process.

Our research highlights the fact that risk in VBM process is dynamic and must be managed through a systems approach. We note that different malicious attacks may have different scopes of impact based on the timing of the attacks. Our findings suggest that mitigations that provide voters with information and recourse actions are crucial for VBM security. In particular, drop boxes enable voters to cast a second ballot when their first ballot is affected by a malicious or non-malicious attack.

Additionally, ballot tracking programs ($M3$) can significantly affect VBM performance. Both drop boxes and ballot tracking programs provide broad protection against attacks. Two notable examples of ballot tracking programs that are currently available are BalloTrax and BallotScout. BalloTrax allows voters to track the status of their mail-in ballots, providing real-time updates when ballots are collected, received, and accepted by election offices [9]. Similarly, BallotScout integrates with USPS to provide voters with detailed information on their ballots’ whereabouts throughout the election process [7].

There are several limitations of our study that provide insight into topics for future research. First, this analysis considers malicious attacks that occur on a single-day and is limited by a lack of historical data regarding malicious attacks. Future research could diversify attack scenarios and incorporate a broader range of data to enhance the model’s sensitivity to resource constraints and varying electoral processes. Additionally, future research could account for resource constraints and system congestion.

Acknowledgments

This work was in part funded by the National Science Foundation Award 2000986. The views and conclusions contained in this document are those of the authors and should not be interpreted as necessarily representing the official policies, either expressed or implied, of the National Science Foundation.

References

- [1] Barry C. Burden. The experiences of municipal clerks and the electorate in the November 2020 General Election in Wisconsin, Sept 2021. URL <https://thompsoncenter.wisc.edu/wp-content/uploads/sites/509/2021/09/Burden-2020-Wisconsin-Election-Report-PUBLIC.pdf>.
- [2] Bipartisan Policy Center. The 2020 voting experience: Lessons learned and recommendations for reform, 2021. URL https://bipartisanpolicy.org/download/?file=/wp-content/uploads/2021/04/EPP-Voting-Experience_RV1.pdf. Accessed: 2024-09-02.
- [3] J. Blessing, J. Gomez, P. McCoy, and T. Ngyuen. Security survey and analysis of vote-by-mail systems. *Computers and Society, Cryptography and Security MIT*, Sept. 2020.
- [4] City of Milwaukee Common Council. Final voting ward demographics. Accessed on: Aug. 4, 2020. [Online]. Available: <https://city.milwaukee.gov/ImageLibrary/Groups/ccCouncil/2012PDF/FinalVotingWardDemographics-Ju.xls>, 2012.
- [5] Cybersecurity and Infrastructure Security Agency(CISA). Mail-in voting in 2020 infrastructure risk assessment and infographic, July 2020. URL <https://www.cisa.gov/publication/election-mail-risk>.
- [6] M. De Witte. Examining effects, challenges of mail-in voting. *Stanford News*, Sept. 2020.
- [7] Democracy Works. Ballotscout. <https://www.democracy.works/ballotscout>, 2021. Accessed: 2024-05-21.
- [8] C. Haseltine, S. Wang, and L. Albert. Dynamic cyber-physical system security planning using attack graphs. In *Proceedings of the IISE Annual Meeting*, Seattle, WA, May 2022. Institute of Industrial and Systems Engineers.
- [9] i3logix. Ballottrax. <https://www.ballottrax.com/>, 2024. Accessed: 2024-05-21.
- [10] J. Li, T. T. Allen, and K. Akah. Could simulation optimization have prevented 2012 central Florida election lines? In *2013 Winter Simulations Conference (WSC)*, pages 2088–2096, Washington, DC, USA, 2013. IEEE.
- [11] C. McIntyre. “What queueing means; polling places Covid-19?” - MIT Election Lab, Aug. 2020. URL <https://electionlab.mit.edu/sites/default/files/2020-08/WhatQueueingMeansPollingPlacesCOVID19.pdf>.
- [12] Milwaukee County. Municipalities, June 2023. URL <https://county.milwaukee.gov/EN/Municipalities>.

- [13] Milwaukee Elections Commission. November 3, 2020 - general election. Nov. 6, 2020, Accessed on: June 5, 2021 [Online]. Available: [https://city.milwaukee.gov/election/ElectionInformation/ElectionResults/2020/November, 2020](https://city.milwaukee.gov/election/ElectionInformation/ElectionResults/2020/November,2020).
- [14] Milwaukee OpenData. Voting wards 2020. Accessed on: Aug. 6, 2020. [Online]. Available: https://data.milwaukee.gov/dataset/voting-wards/resource/01139d6b-b65a-4d63-89da-b87f3986ff0d?inner_span=True, April 6, 2020, 2020.
- [15] MIT Election Data + Science Lab. Voting by mail and absentee voting, Mar. 2021. URL <https://electionlab.mit.edu/research/voting-mail-and-absentee-voting>.
- [16] National Conference of State Legislatures. Report voting outside the polling place: Absentee, all-mail and other voting at home options. Updated on: July 12, 2022. [Online]. Available: [https://www.ncsl.org/elections-and-campaigns/voting-outside-the-polling-place, 2022](https://www.ncsl.org/elections-and-campaigns/voting-outside-the-polling-place,2022).
- [17] National Conference of State Legislatures. Voting outside the polling place: Absentee, all-mail and other voting at home options. Accessed on: June 21, 2023. [https://www.ncsl.org/research/elections-and-campaigns/voting-outside-the-polling-place.aspx, 2022](https://www.ncsl.org/research/elections-and-campaigns/voting-outside-the-polling-place.aspx,2022). <https://www.ncsl.org/research/elections-and-campaigns/voting-outside-the-polling-place.aspx>.
- [18] Office of Inspector General. United States Postal Service performance of election and political mail during the November 2020 general election. Audit report, United States Postal Service, Washington, D.C., Mar. 2021.
- [19] Office of Inspector General. United states postal service performance of election and political mail during the November 2020 General Election. Audit report, United States Postal Service, Mar. 2021.
- [20] S. Rinaldi, J. Peerenboom, and T. Kelly. Identifying, understanding, and analyzing critical infrastructure interdependencies. *IEEE Control Systems Magazine*, 21(6):11–25, 2001. doi: 10.1109/37.969131.
- [21] R. G. Saltman. Accuracy, integrity and security in computerized vote-tallying. *Commun. ACM*, 31(10):1184–1191, oct 1988. ISSN 0001-0782. doi: 10.1145/63039.63041. URL <https://doi.org/10.1145/63039.63041>.
- [22] N. Scala, I. Bloomquist, Y. Mezgebe, and B. Jilcha. A process map and risk assessment for mail-based voting. In A. Ghate, K. Krishnaiyer, K. Paynabar, eds., editor, *Proceedings of the 2021 Institute of Industrial and System Engineers (IISE) Annual Conference*, Towson, MD, 2021.

- [23] N. M. Scala, P. L. Goethals, J. Dehlinger, Y. Mezgebe, B. Jilcha, and I. Bloomquist. Evaluating mail-based security for electoral processes using attack trees. *Risk Analysis*, 42(10):2327–2343, 2022.
- [24] A. Schmidt and L. A. Albert. Designing pandemic-resilient voting systems. *Socio-Economic Planning Sciences*, 80:101174, 2022. ISSN 0038-0121. doi: <https://doi.org/10.1016/j.seps.2021.101174>. URL <https://www.sciencedirect.com/science/article/pii/S003801212100166X>.
- [25] A. Schmidt and L. A. Albert. The drop box location problem. *IISE Transactions*, 56(4):424–436, 2023. doi: 10.1080/24725854.2023.2213754. URL <https://doi.org/10.1080/24725854.2023.2213754>.
- [26] B. Schneier. Attack trees: Modeling security threats. *Dr. Dobb’s Journal*, December 1999.
- [27] J. Shen. *Merge Times and Hitting Times of Time-inhomogeneous Markov Chains*. Dissertation, Duke University, Durham, NC, 2013.
- [28] B. I. Simidchieva, S. J. Engle, M. Clifford, A. C. Jones, S. Peisert, and M. Bishop. Modeling and analyzing faults to improve election process robustness. In *In Proceedings of the 2010 USENIX/ACCURATE Electronic Voting Technology Workshop*, 2010. URL https://escholarship.org/uc/item/0cg3b5vb#article_main.
- [29] C. Stewart. 2016 Survey of the performance of American elections. In *2020 Survey of the Performance of American Elections*. Harvard Dataverse, 2021. doi: 10.7910/DVN/Y38VIQ/SXXGGV. URL <https://doi.org/10.7910/DVN/FSGX7Z>.
- [30] C. Stewart III and S. Ansolabehere. Waiting to vote. *Election Law Journal*, 14(1):47–53, 2015.
- [31] United States Census Bureau. QuickFacts Milwaukee city, Wisconsin. Accessed on: Aug. 5, 2020. [Online]. Available: <https://www.census.gov/quickfacts/fact/table/milwaukeeecitywisconsin/PST045219>, July 2019.
- [32] University of South Alabama. “Election operations assessment; Threat trees and matrices and Threat Instance Risk Analyzer (TIRA)”. Technical report, U.S. Election Assistance Commission (EAC), Washington, D.C., 2009. URL PDF:https://www.eac.gov/sites/default/files/document_library/files/Election_Operations_Assessment_Threat_Trees_and_Matrices_and_Threat_Instance_Risk_Analyzer_%28TIRA%29.pdf.
- [33] Wisconsin Elections Commission. Absentee ballot report, Oct. 2020. URL https://elections.wi.gov/statistics-data/absentee-statistics?combine=field_subject_target_id=Allpage=12.
- [34] Wisconsin Elections Commission. Voting by mail: Note on absentee ballot return, Oct. 2020. URL <https://elections.wi.gov/voters/voting-mail#230548828-2254551794>.

- [35] Wisconsin Elections Commission. Wec releases analysis of November 2020 election data. <https://elections.wi.gov/news/wec-releases-analysis-november-2020-election-data>, 2020. [Online; accessed 28-December-2023].
- [36] Wisconsin Elections Commission. 2020 general election voting and registration statistics report, el-109f. Report, Nov 2020. URL https://elections.wi.gov/statistics-data/voting-statistics?combine=2020&field_subject_target_id=All. Accessed: 1-18-2024.
- [37] Wisconsin Elections Commission. Absentee ballot report - November 3, 2020 General Election. Accessed on: June 5, 2021 [Online]. Available: <https://elections.wi.gov/node/6862>, 2020.
- [38] Wisconsin Elections Commission. November 3, 2020 Election Data report. White Paper, Feb 2021. URL <https://elections.wi.gov/sites/default/files/legacy/2021-01/D.%2520November%25202020%2520Election%2520Data%2520Report.pdf>. Accessed: 1-17-2024.
- [39] M. Yang, M. J. Fry, and W. D. Kelton. Are all voting queues created equal? In *Proceedings of the 2009 Winter Simulation Conference (WSC)*, pages 3140–3149. IEEE, 2009.
- [40] A. Yasinisac and J. Pardue. A process for assessing voting system risk using threat trees. *Journal of Information Systems Applied Research*, 2010.