

Architecture Proposal for 6G Systems Integrating Sensing and Communication

Peter Gersing¹⁾, Mark Doll²⁾, Joerg Huschke³⁾, Oliver Holschke⁴⁾

¹⁾GPP Communication, Oberhaching, Germany

²⁾Nokia Bell Labs, Stuttgart, Germany

³⁾Ericsson, Herzogenrath, Germany

⁴⁾Deutsche Telekom AG, Berlin, Germany

November 2024

Abstract: Integrating sensing functionality into 6G communication networks requires some changes to existing components as well as new entities processing the radar sensing signals received by the communication antennas.

This whitepaper provides a comprehensive overview of the 6G design proposal for ISaC (Integrated Sensing and Communication). The whitepaper has been created by the architecture group of the KOMSENS-6G project. It represents an intermediate state of the work, as the KOMSENS-6G project is still ongoing. The proposal should serve as a basis for further discussions and alignment across innovative 6G projects.

Introduction: The KOMSENS-6G project develops a potential 6G ISaC architecture, along with use cases, protocols and the processing of sensing data. The ISaC service is already in discussions in 3GPP, a feasibility study identified a set of use cases and derived first requirements [1,2]. The existing 3GPP architecture is taken as a basis to propose the 6G architectural concepts for integrating “Sensing” services in communication networks.

This whitepaper addresses the ISaC architecture mainly on logical level. Some implementation and deployment aspects are being included as far as they are relevant to further discussions.

The KOMSENS-6G project is focusing on the network-based sensing, whereas sensing via the UE (User Equipment) is out of scope.

The KOMSENS-6G SysML Model: The architecture group has developed a SysML¹ model (System Design and Modelling Language) of the envisioned ISaC architecture for 6G networks. SysML allows the definition of the system structure as well as the system behavior, including interfaces, message-sequences, data formats and more. Modeling the system supports the consistency of the architecture concepts by serving as a single point of truth. The diagrams of this whitepaper are generated from the KOMSENS-6G SysML Model.

Logical System Architecture for ISaC: Receiving and processing reflected signals (sensing) by communication antennas is the new sensing feature which is to be integrated into the 6G communication systems. The basis for the logical architecture shown in Figure 1 is the current 3GPP 5G system architecture [3], to which we propose modifications to integrate sensing (ISaC). The integration

¹ The SysML language is a standardized graphical language to support the specification of the system structure and the system behavior. The standard is maintained by the OMG (Object Management Group) – <https://www.omg.sysml.org/>.

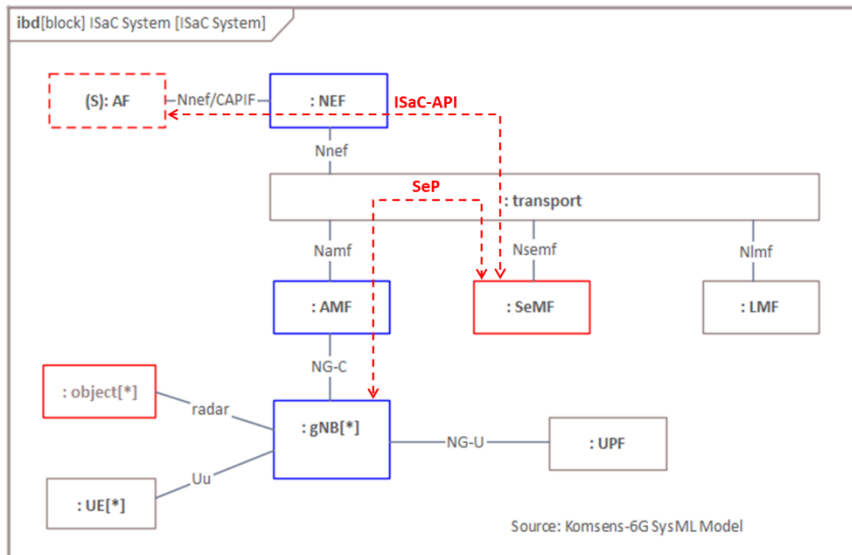

Figure 1: Logical Architecture for ISaC.

of ISaC can be accomplished by enhancing selected existing components (blue) and adding new ISaC components (red). Further architectural options deviating from the baseline have been discussed in the project recently and are being addressed alongside the discussion of the baseline that is following hereafter.

The sensing service will be provided to users via a new ISaC-API (Application Programming Interface).

The new protocols for sensing as shown in Figure 1 as red dashed lines with arrows on both ends are:

- the ISaC-API for exposing the sensing service to an application (AF), and
- the SeP (Sensing Protocol) for the communication between the core (SeMF) and the RAN (gNB).

To support ISaC-API and SeP, the NEF (Network Exposure Function), which interfaces the core with applications like a Sensing AF (Application Function) using the sensing service, respectively the AMF (Access and Mobility Management Function), which interfaces the core with the RAN (Radio Access Network) control plane, are extended. The RAN's base stations (gNB, next Generation NodeB) are enabled to process sensing signals. The new SeMF (Sensing Management Function) in the core implements all remaining sensing tasks that are preferably centralized and manages the overall sensing operation.

Note that we do not propose to integrate sensing into 5G. We use the 5G terminology here solely as placeholders for future 6G architecture functional entities, as those have not yet been defined.

With most sensing processing done in the RAN, the current architecture proposes to transport the reduced rate of sensing data using the CP (Control Plane). The alternative option is an introduction of additional plane named DP (Data Plane) for the transport of sensing data, mitigating limitations and challenges related to scalability and performance of the CP, and enabling more flexible deployment of processing functions between RAN and core network. It will be subject of further studies to compare these two options.

RAN Deployment Architecture: The RAN architecture in current networks is mostly using self-contained gNBs that are distributed in the geographical coverage area, where each gNB consists of Radio Units (RU), each with a connected antenna, referred to as TRP (Transmission and Reception Point), and digital units for processing, as shown in Figure 2. This architecture will still be widely used in 6G networks, and the sensing architecture therefore considers this option.

Yet, sensing and other new 6G features including the application of ML (Machine Learning) and AI (Artificial Intelligence) will require more processing in the RAN. As a result, the design of today's 5G RAN may evolve into a configuration with more processing power in the "Edge Cloud" connecting more RUs via fiber at a wider range of up to 10–30 km (see Figure 2).

The Cloud RAN [4,5] approach of moving RAN functionality to cloud-based edge servers offers notable advantages specifically for sensing, as it will make use of the increased processor performance by the

time 6G networks will be rolling out. It will allow an incremental introduction of sensing services as the technology matures and business cases evolve.

Sensing service from 6G is expected to be extensively applied, as it provides information about the location, velocity, geometry and the surroundings of objects. This is expected to lead to a substantial amount of data that is generated by sensing receiving nodes. These data need to be conveyed over existing/new interfaces and may be postprocessed and/or fused from several receiving nodes at a central unit responsible for a certain geographical area. Furthermore, for bi-/multistatic sensing (see next section), pairs or clusters of gNBs need to be coordinated such that the receiving gNBs switch to sensing receiving mode at the exact time when the sensing transmission occurs. All these aspects suggest that the sensing architecture needs to provide powerful control and data processing, and a sufficiently high bandwidth and low latency interconnections between gNBs.

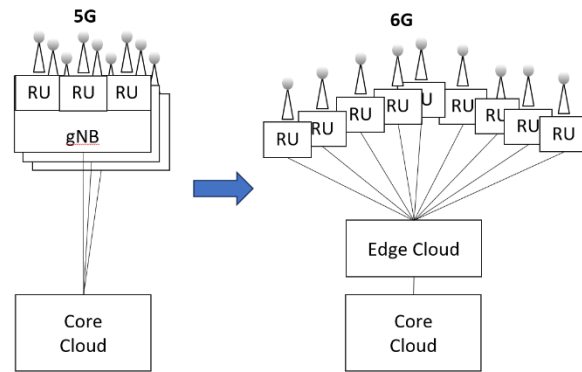

Figure 2: Evolution of the Deployment Architecture.

Furthermore, for bi-/multistatic sensing (see next section), pairs or clusters of gNBs need to be coordinated such that the receiving gNBs switch to sensing receiving mode at the exact time when the sensing transmission occurs. All these aspects suggest that the sensing architecture needs to provide powerful control and data processing, and a sufficiently high bandwidth and low latency interconnections between gNBs.

Sensing Modes: There are two major variants of sensing: monostatic sensing where the sensing TX and RX are co-located, and bistatic sensing where the TX and RX are on different sites. In monostatic sensing, the self-interference from the TX spilling over into the RX is a serious challenge that requires additional hardware efforts. Accordingly, instead of a strictly monostatic setup with a single TRP acting as both TX and RX, a quasi-monostatic setup with two separate TRPs for TX and RX closely co-located at the same site can be used. In bistatic sensing the interference level at the RX can be controlled by the separation to the TX and is manageable without major hardware efforts.

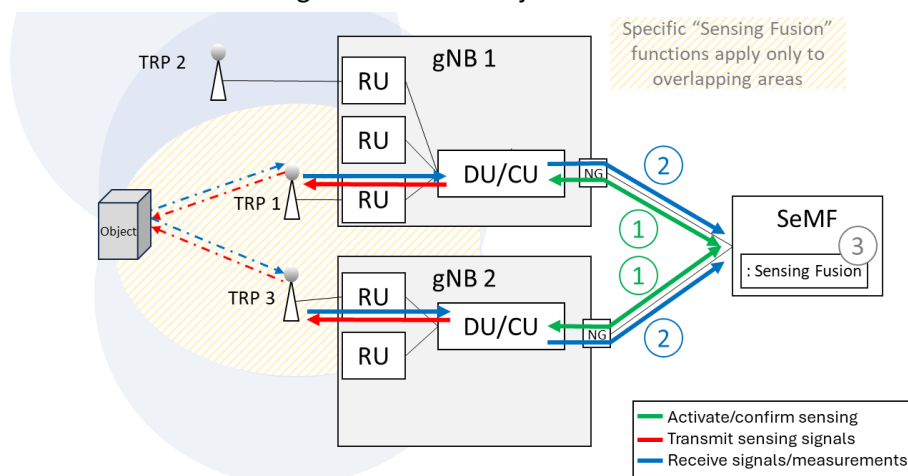

Figure 3 Multi-monostatic sensing.

For multi-monostatic sensing multiple TRPs are being used, measuring in monostatic mode concurrently in an overlapping area as illustrated in Figure 3.

In multi-monostatic sensing, each gNB is individually configured by the SeMF through parallel independent signaling procedures. First, the SeMF activates selected TRPs for sensing. Then accordingly each activated TRP transmits its own distinct sensing signal. From the received signal (reflected sensing signal, i.e., the dash dot line with arrows), each gNB computes the sensing results and reports them back to the SeMF. The SeMF collects all sensing results, and its "Sensing Fusion" function combines them into a more accurate sensing measurement result of the whole area.

A sub-variant of bistatic sensing is multistatic (or multi-bistatic) sensing, illustrated in Figure 4, where there is one sensing TX (part of gNB 1) sending the sensing signal, which is reflected and received by multiple RXs. This may also involve a combination of a (quasi-)monostatic and a bistatic transmission

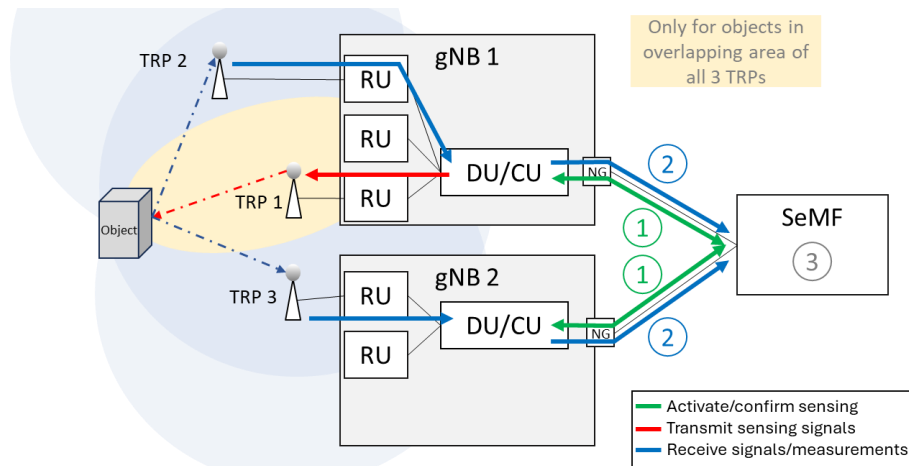

Figure 4: Multistatic (multi-bistatic) sensing.

where the reflected TX signal may be received by one RX on the same site and by additional RXs at neighboring sites. The signaling follows the same principle as in Figure 3, though here it forms a joint procedure in which no sensing occurs if configuration of either TX or RX gNB fails. Like in multi-monostatic, multiple concurrent multi-bistatic sensing operations are possible, i.e. there can be multiple TX transmitting with overlapping coverage, if orthogonal the TX signals are configured.

RAN Logical Architecture: Enhancing the RAN for sensing requires processing of the reflected TX (transmit) signals received on the same frequency. The logical RAN architecture with ISaC enhancements is shown in Figure 5. Existing communication functionality is maintained as is. The RU

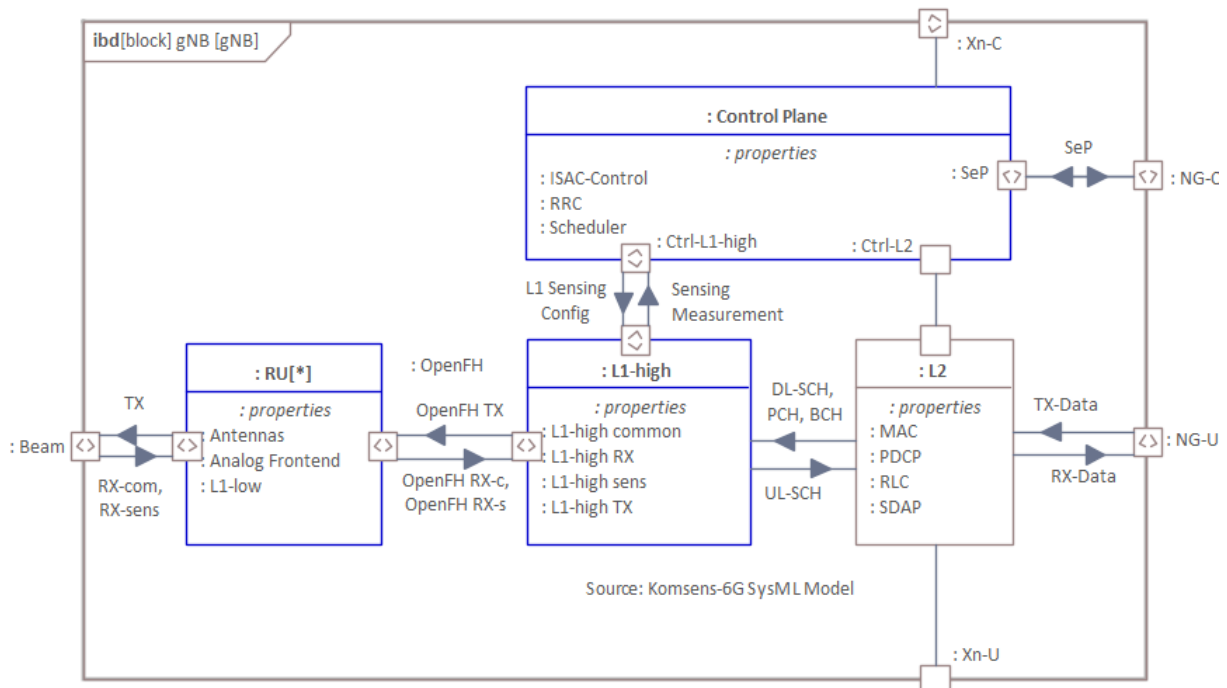

Figure 5: RAN Architecture for ISaC.

connects via the OpenFH (O-RAN Open Fronthaul [6]) interface to the digital processing part of the RAN. The “OpenFH TX” and the “OpenFH RX-c” message represent the existing OpenFH messages for communication. For sensing the “OpenFH RX-s” message is being added, which may closely resemble the RX-c message if OFDM (Orthogonal Frequency Division Multiplexing) radar like sensing (see section Sensing Signal Processing below) is used.

Control Plane

The gNB architecture shown in Figure 5 includes the new sensing control function “ISaC-Control”. The sensing functionality of the RAN is requested and controlled by the SeMF via SeP over the NG-C interface. Sensing processing follows the same processing as communication up to “L1-high”, wherein the sensing signal is processed separately by “L1-high sens”, and from which all requested sensing measurement results are then extracted and forwarded via SeP to the SeMF.

The Radio Resource Control (RRC) is an established protocol running between the gNB and the UE. In the context of sensing it is involved when UEs are acting as sensing transmitter or receiver, which is out of scope for KOMSENS-6G.

The “Scheduler” performs dynamic allocation of radio resources among all active users and services, multiplexing the limited resources among them. In doing so, the scheduler needs ways to trade off the performance between sensing and communication demand. For ISaC we can distinguish these options:

- 1) Communication and sensing each use their own signals and are multiplexed
- 2) Communication signals are reused as sensing signals.
- 3) Communication signals are reused for sensing opportunistically where this is possible, and inserting sensing signals where reusing communication signals is insufficient. This can be regarded as a combination of case 1) and case 2).

The scheduler can make use of these options, also depending on policies or priorities between communication and sensing.

A resource allocation pattern that is uniform—in particular periodic—in time and frequency, has advantages regarding processing complexity. The scheduler can aggregate the requirements from multiple sensing requests and may be able to fulfill it by a more efficient (smaller) resource allocation than the sum of the allocations for serving each request individually.

In TDD (Time Division Duplex) systems sensing transmissions would be preferably scheduled in downlink slots. In bi-/multistatic sensing, the receiving TRPs may belong to different gNBs. In this case the sensing schedule needs to be signaled also to the RX-gNB as shown in Figure 6.

As sensing resource allocation is preferably periodic, the SeMF can determine required resource allocation characteristics and signal them to all involved gNBs, whose schedulers then consider it during resource allocation. Such preconfigured sensing signals (case 1) in the list above) have the advantage that the configuration information

completely defines the sensing signal for the receiver.

Instead of relying on dedicated preconfigured sensing signals, in case 2) downlink data transmissions are reused. As the RX-gNB does not know the TX signal in advance, it must receive it from the TX-gNB either directly over the air, typically over a LOS (Line-of-Sight) path, or via backhaul as depicted in Figure 6 (in monostatic sensing the TX signal is readily available as it is the same gNB).

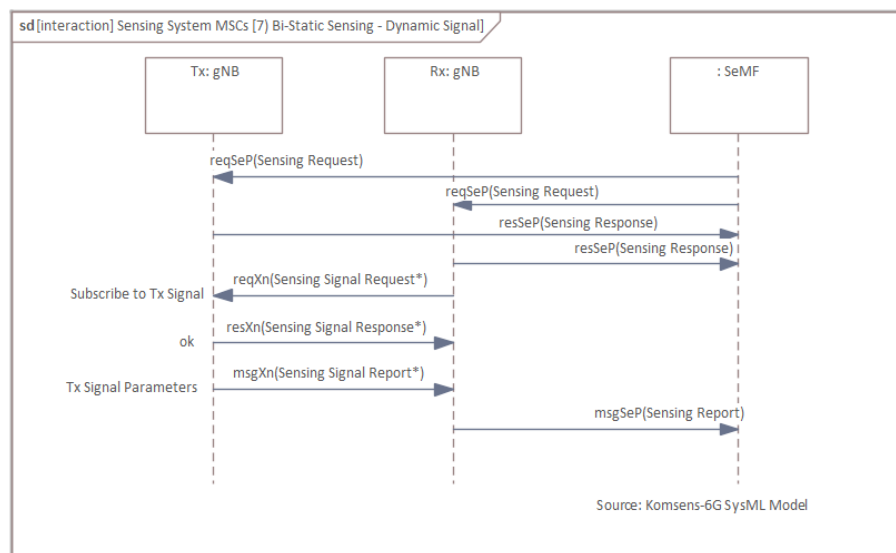

Figure 6 Bistatic sensing on dynamic signals.

Over the air only works with communication signals using wideband precoding (as any per sub-band precoding weights cannot be inferred from the received signal), and decoding may fail, depending on SINR (Signal-to-Noise and Interference Ratio) in relation to the MCS (Modulation and Coding Scheme) used for the communication signal. Via backhaul requires a sufficiently high bandwidth interconnection for conveying the TX signal, e.g., as frequency domain IQ samples, at the time of transmission, and with the interconnection being sufficiently low latency or the sensing receiver having sufficient receive IQ sample buffer space for buffering the received (sensing) signal until the TX signal has arrived over backhaul.

Since communication is predominantly scheduled dynamically, reusing communication signals for sensing is opportunistic in nature. At times when there is no ongoing communication in direction of interest for sensing, a sensing signal needs to be transmitted to fulfill the sensing request, leading to case 3). The overall sensing schedule may still be determined by the SeMF and the sensing TX-gNB scheduler can then decide whether it sends a communication signal or a known sensing reference signal on a scheduled sensing resource. In bi-/multistatic sensing, the RX-gNBs could receive the sensing schedule from the SeMF and their schedulers would have to switch to RX mode in the sensing resources and would have to schedule their communication around them.

If the sensing transmission and reception is supposed not to follow a semi-statically configured schedule from the SeMF, dynamic scheduling flexibility can be provided. While no issue in monostatic sensing, in bi-/multistatic sensing the scheduler in the TX-gNB must inform the RX-gNBs with sufficient time ahead due to inherent delay between two gNBs to switch to sensing RX mode. Since this typically has an impact on the RX scheduler, the dynamic scheduling could imply some brief handshake between the TX-gNB and RX-gNB before the actual sensing transmission starts. Such delay-critical signaling between TX-gNB and RX-gNB needs to use a direct RAN-internal low-delay interface like a 6G evolution of the Xn interface or a link to a control unit in the RAN.

The described time critical coordination of high number of gNBs may suggest having a part of the control functionality in the RAN instead of the CN. To what extent coordination functionality should be moved to the RAN will be further investigated.

Sensing Signal Processing

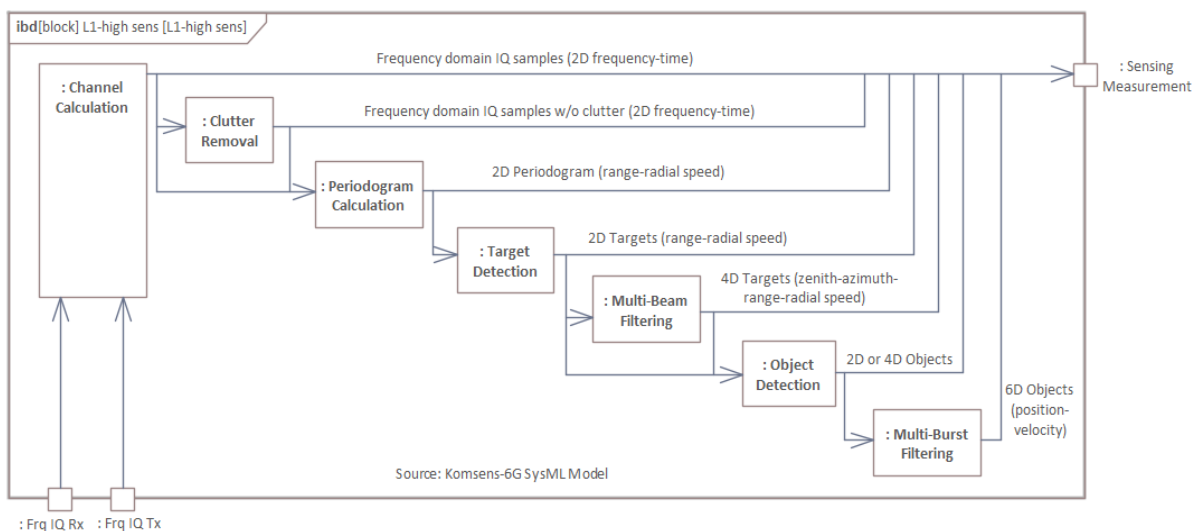

Figure 7: Architecture of "L1-high sens" with processing options.

The "L1-high" in Figure 5 includes a new component "L1-high sens" for the digital processing of the sensing signal. Figure 7 outlines the details of "L1-high sens" in case of an OFDM based radar [7] sensing.

"Channel Calculation" calculates the effective radio channel, independent of the actual transmitted sensing signal, to be captured in the output IQ (Inphase Quadrature) samples.

From the effective radio channel, “Clutter Removal” removes major channel components identified as being clutter, i.e., as being channel components of no interest. The clutter removal also enables detection of weak targets that otherwise may be masked by possibly stronger clutter channel components. It is an optional feature that can be skipped, e.g., when the (semi-)static environment is to be sensed.

Next, “Periodogram Calculator” computes a complex-valued 2D periodogram, i.e., a complex-valued 2D matrix with range and radial or bistatic speed (calculated from delay and Doppler) as dimensions. To reduce computational effort, prior to periodogram calculation, the input IQ samples may be reduced by cropping (reducing the achievable resolution) and/or decimation (reducing the unambiguous value range) in frequency and/or time.

The “Target Detection” extracts targets by searching for local power maxima within the periodogram. Up to this point, a single sensing burst, i.e., a (continuous) coherent receive signal, is used as input. The following “Multi-Beam Filtering” filters in space, using multiple sensing bursts from different receive beams to provide a location estimate for each target in from of an estimated azimuth (AoA) and zenith (ZoA) angle of arrival.

Before filtering in time, an “Object Detection” needs to identify which target point in the 2D or 4D point cloud stems from the same object as a respective target point in prior point clouds, possibly taking into account prior results from “Multi-Burst Filtering” to improve correct mapping of target points to objects. Object detection may group multiple targets into a set of points, if they are deemed to stem from a single physical object like a human or car. For each detected object, “Multi-Burst Filtering” updates the object’s estimated position and velocity in 3D space with the current sensing sample. Specifically, the direction of travel is determined.

The spatial filtering may be skipped, e.g., in case of simple TRPs like small cells that typically lack beam steering capability, or when the use case does not require it, or when timely reporting of sensing measurements is more important. 2D targets may then be reported as is, or “Object Detection” may identify and possibly group targets based on proximity, specifically if subsequent filtering in time is to be done.

Not all the above processing steps need to be performed all the time and/or on all parts of the periodogram and/or for all targets, depending on how “ISaC-Control” has configured “L1-high sens”. Channel estimation may have been done already in the RU. The gNB may leave object detection and tracking to the SeMF, reporting (possibly spatially filtered) target point clouds to the SeMF. Specifically, if “L1-high sens” processing stops prior to “Target Detection”, the created high volume periodogram data or IQ sample stream may motivate a dedicated DP for forwarding such data and possibly a part of the sensing data processing and fusion happening in a processing node in the RAN.

In an edge cloud deployment, some or all of the processing steps may be realized as one or more VNFs (Virtual Network Function), specifically target and object detection, and spatial and temporal filtering. Furthermore, all presented functions may be partly or fully realized through AI/ML (Artificial Intelligence/Machine Learning), e.g., as a DNN (Deep Neural Network) that inputs IQ samples and outputs 2D or 4D target point clouds, or even readily identified and tracked objects.

TRP and RU: For the RU the main challenge is the interference of concurrent strong TX signals with the low power RX (received sensing) signals. Three different RU architectures are considered to cover different deployments: TDD as shown in shown in Figure 8, FDD (Frequency Division Duplex) as shown in Figure 9 and “Sniffer” (separate RX-only TRP) as shown Figure 10, each adding the necessary functions (marked in red) for sensing. When receiver and transmitter are co-located, there is high self-interference, thus, for SIC (Self-Interference Cancellation) following options are proposed:

- antenna isolation and/or shielding of RX from TX antenna array,
- analog signal cancellation on RF (radio) or BB (baseband) frequency, i.e., prior or after RF down-conversion,

- digital signal cancellation in time or frequency domain, i.e., prior or after FFT (Fast Fourier Transform), allowing better signal compression for transport over the OpenFH interface.

In bi-/multistatic sensing, self-interference can be avoided by pausing all communications on RUs acting as sensing receivers with the drawback of increasing the overhead of sensing, but with the advantage that legacy TDD RUs can be used as sensing receivers without modifications.

The impact of interference from adjacent carriers and neighboring cells still needs to be analyzed.

RU for TDD

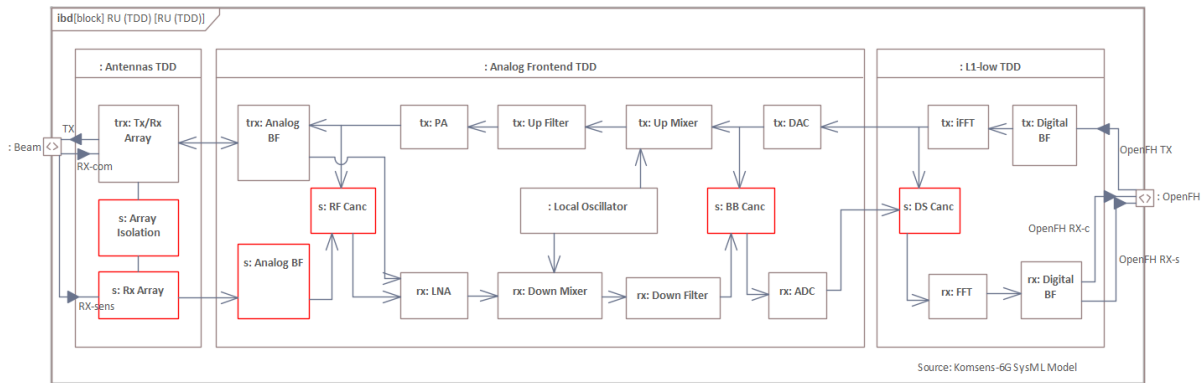

Figure 8: ISaC Radio Unit Architecture for TDD.

Figure 8 depicts the internal architecture of an ISaC-capable TDD RU. All newly introduced functions for sensing are highlighted in red. In TDD operation, when a TRP acts as sensing transmitter, the same RX path can be used for both sensing and communication: During the uplink (UL) part of the TDD period, the RX path is used for communication, and during the downlink (DL) part it is used for sensing. The “s: RX Array” (s: sensing) used solely for sensing may be realized as part of the “trx: TX/RX Array” (trx: transmit and receive) for communication, which is reconfigured for sensing such that one part acts as TX array for transmitting sensing signals and user data, and another part as RX array for receiving sensing signals. The RU may solely employ analog beamforming (BF) as it is typical for mm-wave frequencies. An RU with hybrid or fully digital beamforming typical for cm-wave frequencies additionally or exclusively has a second respectively its only beamforming function within “L1-low TDD” before the iFFT and after the FFT, respectively. “L1-low TDD” must have enough processing power for processing received signal, not only during the UL part but additionally during the DL part of the TDD period.

While the above introduced means of self-interference mitigation (in red) are strictly necessary only for monostatic sensing, bi-/multistatic sensing also benefits as communication on the RUs acting as sensing receiver then can continue during sensing.

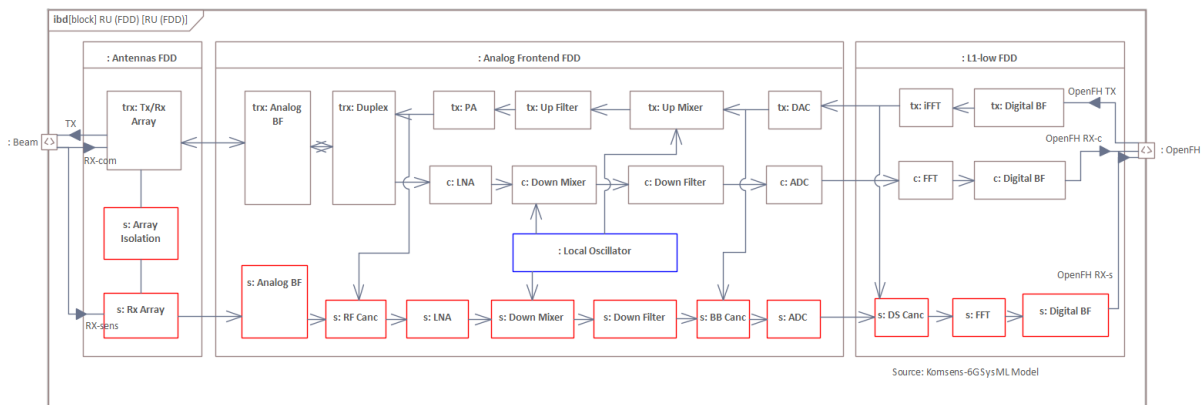

Figure 9: ISaC Radio Unit Architecture for FDD.

RU for FDD

For FDD, as shown in Figure 9, the logical architecture of the RU comprises an additional RX path to enable monostatic (both TX and RX in one RU), as well as bistatic (TX and RX in different RUs) sensing. While both RX paths, communication (c) and sensing (s), comprise logical components of the same type, the communication path operates on UL frequency, while the sensing RX path operates on DL frequency, the same frequency as the TX path. Accordingly, the same self-interference mitigation techniques as for TDD are needed for the sensing RX path (but not for the communication RX path)—except the RU is only used for bi-/multistatic sensing and during sensing reception all communication is paused.

Sniffer RU

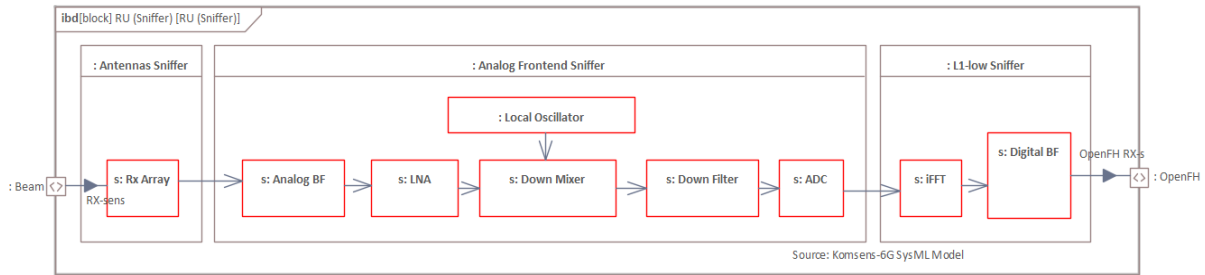

Figure 10: ‘Sniffer’ (receive only) ISaC Radio Unit Architecture

When an RU is used only for receiving (sensing) signals, it can be operated in ‘sniffer’ mode, see Figure 10. The sniffer RU may be a standard TDD RU with its TX path deactivated, or the RU is purpose-built without TX path. As the TX path is either inactive or even missing, interference cancellation is not required. The “Sniffer” is applicable to a quasi-monostatic setup, i.e., where a second co-located TRP acts as sensing transmitter, and where the sniffer RU respectively its RX antenna can be placed such that the required isolation from the TX antenna of the co-located TRP is achieved.

Core Function SeMF: The “Sensing Management Function” is added to the core functions to anchor all new functions required for the integration of sensing, see Figure 11. It offers its services to other core functions via the Nsemf interface.

The SeMF provides the “ISaC-API” to expose the sensing service to external applications. The SeMF controls the RAN sensing functions via the SeP. Both, ISaC-API and SEP communication interfaces have been described as part of the architecture proposal.

The SeMF contains several subfunctions, namely:

- **ISaC-API Engine** manages the communication with the sensing-application on the user side.

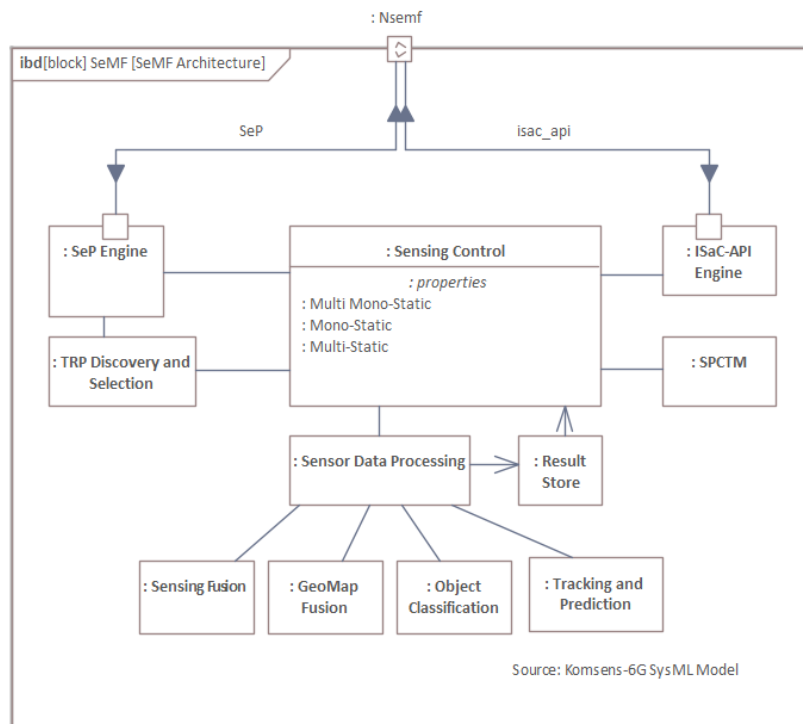

Figure 11: Core Architecture of the Sensing Management Function (SeMF).

- **SeP Engine** manages the communication with the RAN via the NG interface.
- **Sensing Policy, Consent & Transparency Management (SPCTM)** manages the privacy aspects of sensing.
- **Sensing Control** manages all network actions for any Sensing Trigger received from the API.
- **TRP Discovery and Selection** discovers available TRPs and activates the TRPs for sensing in the requested area as needed.
- **Sensing Data Processing** processes the received sensing data according to the request.
- **Sensing Fusion** uses sensing information from multiple TRPs to obtain the requested sensing result.
- **GeoMap Fusion** combines existing (available) 3D models with the sensing information.
- **Object Classification** identifies the type of object (building, car, human, etc.).
- **Tracking and Prediction** identifies moving objects, tracks and predicts object movements.
- **Result Store** stores object locations and updates with every scan. Includes results from data processing before passing it on to the application function (AF). The Result Store can also serve multiple API-requests for the same area w/o initiating a sensor scan for each request.

As subfunctions become more refined, selected subfunctions may become separate entities like sensing processing (the last six subfunctions above), with own interfaces to core and RAN, possibly using a new DP for sensing, and which may be co-located with the SeMF or be deployed in an edge cloud or in the RAN, especially if the gNBs are only tasked to preprocess sensing signals, creating large volumes of sensing measurement data.

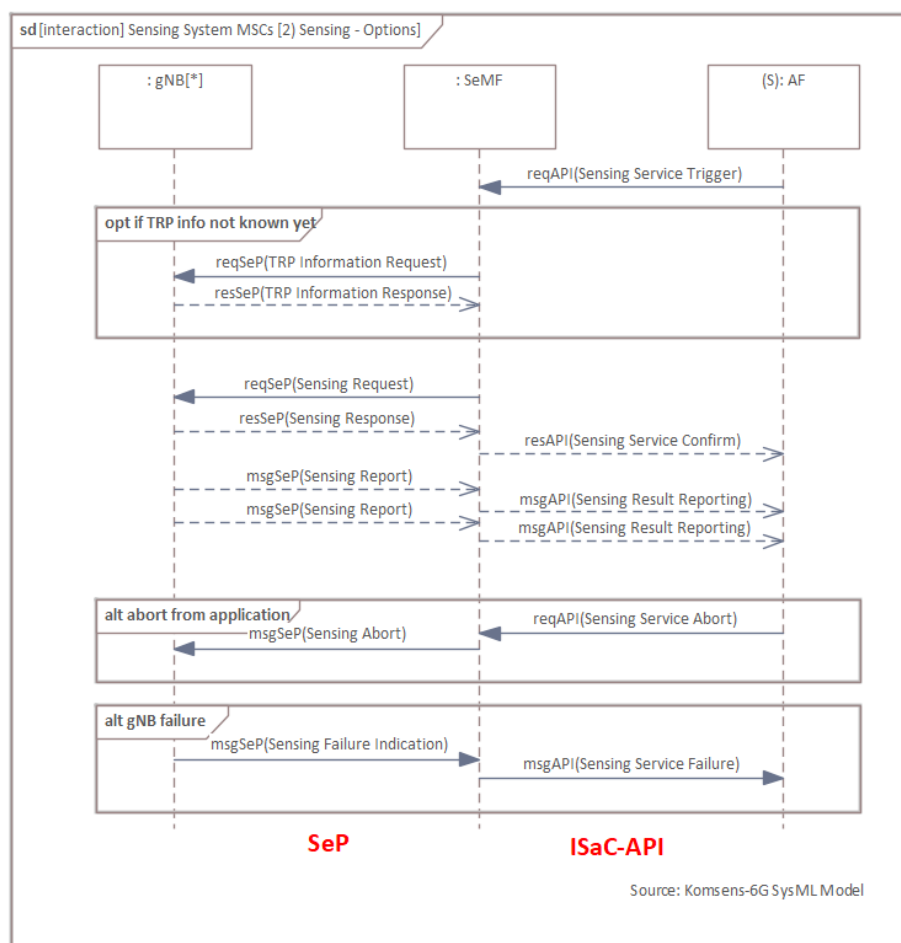

Figure 12: Message Sequence of Sensing Service.

Signaling Flow and Protocols: A typical message flow for processing a sensing request from a sensing AF is shown in a sequence diagram in Figure 12. If the TRP information is not yet known, it is retrieved

from the RAN. When the TRP information is available, a sensing request is passed to the gNB. The sequence can end by providing sensing results or by termination via API or gNB failure indication. Note that more message sequences are available for the SeP as well as for the ISaC-API, defining successful and unsuccessful operations in the KOMSENS-6G SysML Model but are not included in this whitepaper.

The SeP

The “Sensing Protocol” has been designed to enable the SeMF core function to control the sensing functions in the RAN. The SeMF uses SeP to activate desired TRPs for sensing, and request sensing-related information and measurements from TRPs. Figure 13 shows the BDD (Block Definition Diagram) defining the set of SeP messages and their highest level IEs (Information Element). Further details of the IEs are specified in the KOMSENS-6G SysML Model.

Table 1: Procedures for capability retrieval and sensing operation.

Procedure Name	Initiating Message	Successful Outcome Response message	Unsuccessful Outcome Response message
TRP Information Exchange	TRP Information Request	TRP Information Response	TRP Information Failure
Sensing	Sensing Request	Sensing Response	Sensing Failure

SeP consists of two sets of procedures, one for the SeMF to request information about TRP properties and capabilities (1st row in Table 1, and Figure 13) and the other to carry out the actual sensing measurement operations.

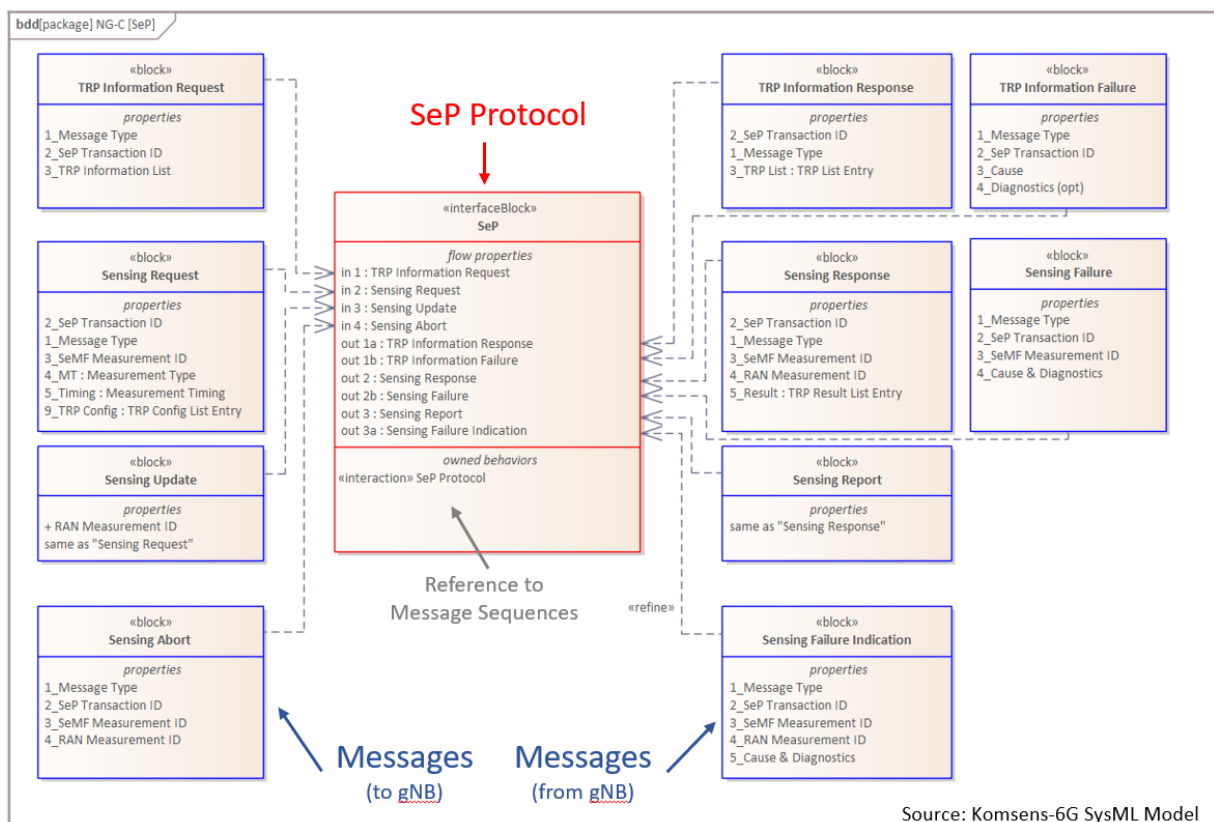

Figure 13: Sensing Protocol (SeP) Messages and Parameters.

With “Sensing Request” the SeMF activates sensing operation in the RAN with the configuration given in IEs “TRP Config List Entry”. The contacted gNB either fully acknowledges the request with “Sensing Response”, providing its own “RAN Measurement ID” for later reference and reporting of results, or (fully) rejects it with “Sensing Failure”, then including “Cause & Diagnostics” providing the reason for the rejection. The case when a gNB may only be able to partially acknowledge a request with possibly

modified measurement configuration(s) is still to be defined. When the SeMF has requested an immediate one-shot (aka on demand) measurement in “Measurement Timing”, “Sensing Response” already carries the sensing measurement results in IEs “TRP Result List Entry”, and the sensing measurement operation is terminated with this message.

“Sensing Update” enables the SeMF to modify an ongoing (periodic) sensing measurement operation as identified by the tuple of “SeMF Measurement ID” and “RAN Measurement ID” within the prior acknowledged configuration, with details still to be defined. “Sensing Report” is used for periodic reporting of sensing measurements, either until the configured sensing duration (provided before in “Measurement Timing”) has been reached or the sensing measurement operation is terminated by the SeMF with a “Sensing Abort”. This message is also used in case a failure occurs on SeMF side. Conversely, “Sensing Failure Indication” allows the RAN to abort an ongoing sensing measurement operation in case of a failure on RAN side.

The ISaC-API

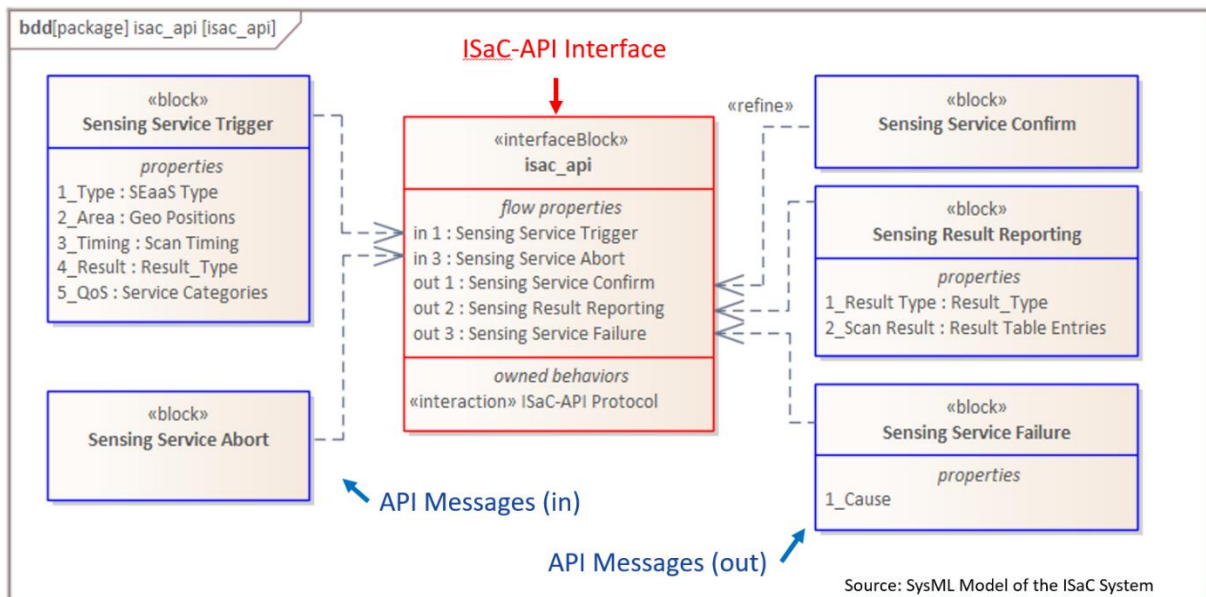

Figure 14: ISaC-API Messages and Parameters.

The sensing service is exposed through an ISaC-API that has been defined within the KOMSNES-6G project. The ISaC-API (illustrated in Figure 14) defines functionalities such as triggering sensing, results reporting, service abort or failure. The ISaC-API has been checked against top use cases of KOMSENS-6G to validate the completeness of the functionalities.

Security and Privacy Aspects: Although this white paper focuses on a functional view w.r.t. the ISaC architecture we want to give a very short introduction of the security and privacy controls envisioned for the ISaC architecture. More details will be given in a follow-up white paper dedicated to security and privacy. If the sensing targets involve human beings, data protection regulations such as the GDPR (General Data Protection Regulation) apply since the sensing data contain personal data.

The SPCTM (Sensing Policy, Consent & Transparency Management) is the responsible component for governing the access to the sensing data. Therefore, access control mechanisms need to be defined, which ensure that the access to sensing data is in line with the policies set in the 6G ISaC system. The sensing policy covers aspects such as who is allowed to access which sensing data with which frequency for which purposes etc. The policy decision includes consent aspects, e.g., if sensing at a given location is allowed or not (e.g., if the owner of a property has given their consent for sensing). While the sensing is executed, transparency information is made available (e.g., by means of cell broadcast) to inform human sensing targets according to the obligations outlined in the GDPR. SPCTM includes mechanisms

for data minimization, which ensure that the sensing data exposed to the application function contains only the minimal necessary data for the given purpose and use case.

Summary: The KOMSENS-6G project has identified a first set of functions to realize an ISaC system in future 6G mobile communication systems. The proposed architecture is lean to minimize impact on other functionalities and implementation complexity. All core functions related to sensing are consolidated in a single new core network function named SeMF. The sensing service is exposed via the ISaC-API provided by the SeMF. On the RAN side, baseband processing is amended by a second dedicated processing chain “L1-high sens” for sensing besides the existing “L1-high comm” for communication services, and an extended resource (de)mapping for (de)multiplexing frequency IQ samples among both pipelines. In a Cloud RAN deployment, “L1-high sens” may be initially realized with existing communication-only gNBs by implementing most of the sensing-related processing as VNFs running on the edge cloud. “L1-high sens” is complemented by the new “ISaC-Control” control layer function. It represents the RAN-side endpoint of the SeP, by which the SeMF controls sensing operations in the RAN and receives the sensing measurements back from the RAN. For monostatic sensing a second RU in receive-only configuration (“Sniffer RU”) can be used, which is physically separated from a co-located communication RU acting as sensing transmitter. For bi-static sensing communication transmissions can be paused, while sensing signals are received. Future ISaC-capable RUs may support concurrent transmission and reception on the same carrier through suitable self-interference mitigation. Mechanisms to suppress interference from other carriers/sectors/sites are needed in all sensing modes.

Outlook: The KOMSENS-6G project will refine and complete both ISaC-API and SeP as well as RAN-internal signaling for synchronization and coordination, by the end of the project. Furthermore, the introduction of a DP (Data Plane) into the future 6G architecture may be relevant not just to sensing but to further research projects in and outside of the 6G platform.

Acknowledgement: This work has been supported by the Federal Ministry of Education and Research of the Federal Republic of Germany as part of the KOMSENS-6G project (16KISK). We would like to thank Stefan Köpsell from Barkhausen Institute for his input on security and privacy aspects of sensing.

References:

- [1] 3GPP, "Feasibility Study on Integrated Sensing and Communication," 22.837 V19.4.0, June 2024. [Online]. <https://www.3gpp.org/DynaReport/22837.htm>
- [2] 3GPP, "Service requirements for Integrated Sensing and Communication; Stage 1," TS 22.137 V19.1.0, February 2024. [Online]. <https://www.3gpp.org/DynaReport/22137.htm>
- [3] 3GPP, "System architecture for the 5G System (5GS); Stage 2," TS 23.501 V19.0.0, June 2024. [Online]. <https://www.3gpp.org/DynaReport/23501.htm>
- [4] Ericsson. (2022) Cloud RAN Acceleration Options. [Online]. <https://www.ericsson.com/4ae403/assets/local/ran/doc/cloud-ran-acceleration-technology-positioning-paper.pdf>
- [5] Nokia. (2023) Cloud RAN: A Guide to Acceleration Options. [Online]. <https://onestore.nokia.com/asset/f/213050>
- [6] O-RAN Alliance, "O-RAN Working Group 4 (Open Fronthaul Interfaces WG): Control, User and Synchronization Plane Specification," O-RAN.WG4.CUS.0-R003-v15.00, June 2024. [Online]. <https://specifications.o-ran.org/specifications>
- [7] Martin Braun, *OFDM Radar Algorithms in Mobile Communication Networks*. Karlsruhe, Germany: Karlsruhe Institute of Technologie (KIT), 2014. [Online]. <https://publikationen.bibliothek.kit.edu/1000038892>