

Josephson effects in a superconductor-normal metal mesoscopic structure with a dangling superconducting arm.

R.Shaikhaidarov⁺, A.F.Volkov^{*†}, H.Takayanagi⁺, V.T.Petrashov^{*}, P.Delsing[‡]

⁺*NTT Basic Research Laboratories,*

3-1 Wakamiya, Morinosato, Atsugi-shi, Kanagawa 243-0198, Japan

^{*}*Theoretische Physik III, Ruhr-Universitaet Bochum*

Universitaetsstrasse 150, D-44780 Bochum, Germany

[†]*Institute of Radioengineering and Electronics of the Russian*

Academy of Sciencies, Mokhovaya str.11, Moscow 103907, Russia.

^{*}*Royal Holloway University of London*

Egham, Surrey TW20 0EX, U.K.

[‡]*Department of Microelectronics and Nanoscience, Chalmers University of Technology*

SE-412 96 Goteborg, Sweden

(November 1, 2018)

We studied a mesoscopic cross-like normal metal structure connected to two superconducting (S) and two normal (N) reservoirs. We observed the Josephson effect under unusual conditions when there is no current through one of the two S/N interfaces. The potential difference between the S reservoirs was zero unless the voltage applied between S and N reservoirs exceeded a critical value although the electric potential in the N wire connecting the superconductors varied in a nonmonotonic way. The observed effects are discussed theoretically.

PACS number: 74.50.+r, 73.23.-b, 85.25.-j

The first studies of transport in superconductor-normal metal (S/N) mesoscopic structures were focused on the dependence of the normal metal conductance G_N on the phase difference φ between the superconductors S. It was established that G_N is a periodic function of the phase difference φ ¹⁻⁶. The other problem - the effect of a current in the normal wire on the critical Josephson current I_c (see Fig.1) - has been studied recently. Amongst other findings obtained in the course of these studies there are two remarkable effects. The first one is the so-called sign reversal effect. The critical current I_c changes sign in the structure similar to the one shown in Fig.1 if the current flowing between the N reservoirs exceeds a certain value. This effect was studied in a Nb/Au mesoscopic structure with a short mean free path (diffusive regime)⁷. The sign reversal effect was analyzed theoretically in Refs.⁸⁻¹⁰ (ballistic regime) and in Refs.¹¹⁻¹⁴ (diffusive regime). Another interesting effect was observed in a diffusive Al/GaAs mesoscopic structure¹⁵. It was found that an additional current driven through the doped semiconductor GaAs results in a non-monotonic behavior of the critical current in the Al/GaAs/Al Josephson junction I_c . The current I_c first decreases with increasing V_N , then increases and reaches a maximum value I_m when the voltage between the semiconductor and superconductors V_N is of the order Δ/e . This effect was analyzed theoretically in Refs.^{12,16}.

In both cases mentioned above an additional current was passed through the normal wire. However the critical current was measured as the critical current in an ordinary Josephson S/N/S junction; i.e. as a maximum current flowing through both S/N interfaces at zero voltage between the superconductors. It turns out that Josephson-like effects can be observed in multiterminal structures under rather unusual conditions when there is no current through one S/N interface. Consider the structure shown in the Fig. 1. Reservoirs S' and one N' are disconnected from the external circuit and the current flows from the right N reservoir to the upper S reservoir. In this structure Josephson-like effects also arise. The prediction was made in Ref.¹¹ and briefly discussed in Ref.¹⁷, but up to now it was not observed experimentally. In this paper we report on experimental studies of the effect, discuss its physical nature and present results of theoretical analysis.

First we discuss the physics of the effects using a simple phenomenological model. Later the main features of this model will be reproduced on the basis of a microscopic approach. For simplicity we consider a structure similar to that shown in Fig.1 in which the left N' reservoir is absent. The currents in the normal wires can be written as follows

$$I_{1,2} = I_S + I_{qp1,2} \quad (1)$$

$$I = (V_0 - V_N)/R_h(\varphi) \quad (2)$$

Here $I_S = I_c \sin \varphi$ is the supercurrent in which the critical current is a function of the electric potential V_N , the second term in Eq.(1) is the quasiparticle current: $I_{qp1,2} = \pm(V_{S,S'} - V_0)/R_{1,2}(\varphi)$, V_0 is the potential at the crossing point, $V_{S,N}$ are the potentials at the S and N reservoirs, the potential at the S' is set equal to zero (the potential V_N is negative if V_S is positive). The resistances of horizontal and vertical arms $R_h, R_{1,2}$ are functions of the phase difference φ ; in the case of a weak proximity effect they can be represented in the form $R_{1,2}(\varphi) = R_{1,2} - \delta R_{1,2} \cos \varphi$. Consider first the dc effect when $V_S = \hbar \partial_t \varphi / 2e = 0$. The current through the dangling superconducting arm is zero; this means that $V_0 = -I_c R_2 \sin \varphi$, i.e. the quasiparticle current is compensated by the supercurrent. Excluding V_0 from Eqs. (1-2) and assuming that $R_1 = R_2$, we obtain

$$V_N = -(R_h(\varphi) + R_1(\varphi)/2) \cdot 2I_c(V_N) \sin \varphi \quad (3)$$

$$I = I_1 = 2I_c(V_N) \sin \varphi \quad (4)$$

Eq.(3) determines a relation between φ and V_N and Eq.(4) describes the form of the I-V curve if the phase difference φ is expressed as a function of V_N . Therefore the phase difference in this structure is not arbitrary, but is governed by the voltage V_N . Particularly in the case of the small voltage V_N , we obtain for the phase difference $\varphi \cong -V_N/(2I_c R_0)$ and for the current $I = -V_N/R_0$, where $R_0 = (R_h + R_1)/2$. In the limit of high voltages the resistance of the structure increases to the value $(R_h + R_1)$. The critical voltage V_{cr} is defined as a maximum voltage $|V_N|$ above which a finite voltage arises between the superconductors. This value can be found from Eq.(3) as a maximum $|V_N|$ for which a solution of Eq.(3) exists. Then, as follows from Eq.(4), the effective critical current I_{cr} is equal to

$$I_{cr} = 2I_c(V_{cr}) \sin \varphi(V_{cr}) \quad (5)$$

If the voltage V_N or the current I exceeds the critical value, one needs to solve Eqs.(1-2) taking into account a finite voltage V_N between the superconductors. These equations cannot be reduced to a dynamic equation for the phase φ which describes a single Josephson S/N/S junction. However in this paper we will not discuss ac Josephson effects in the structure under consideration.

The analysis of the situation, when a current I is passed between a normal reservoir and one of the superconductors, carried out on the basis of this simple model shows the following features. For $|V_N| < V_{cr}$ the potential difference between superconductors remains zero, therefore a vertical line on the $I(V_S)$ curve should arise; a nonlinear part with a finite slope on $I(V_N)$ curve should appear. For $|V_N| > V_{cr}$ a kink appears on the current-voltage characteristics. This picture is confirmed by the present experimental data and by a theoretical analysis carried out with the help of a microscopic theory (quasi-classical Green's function technique).

The sample geometry is shown schematically in Fig.1. The structure we studied consists of two crossed, 50 nm thick and 110 nm wide Ag wires with 50 nm thick and 500 nm wide Al leads attached to the vertical wire and 350 nm thick and 20 μm wide Ag reservoirs attached to the horizontal wire. Electron beam lithography and lift-off technique were used to produce samples. In order to ensure high transparency interfaces, we cleaned the Ag films before the evaporation of the Al film via Ar sputtering. The interface resistance was estimated to be of the order of the normal state resistance of the sample. We determined the mean free path $l = 37$ nm and the diffusion constant $D = 124$ cm²/s from the measured resistance of Ag wire. The phase breaking length $L_\varphi = 1.5$ μm was obtained from magnetoresistance measurement of a coevaporated Ag wire at the base temperature. The length of the normal part $L_{NN'}$ and the distance between the superconductors $L_{SS'}$ were 1.3 μm and 0.5 μm respectively. The coherence length of the normal metal is equal to $\xi_T = \sqrt{\hbar D/k_B T} = 1.3$ μm at the base temperature 50 mK.

We performed measurements as follows. The current I was passed between the normal reservoir N and superconducting reservoir S (see Fig.1). The reservoirs N' and S' were not connected to the measurement circuit. We measured the voltage V_1 between the N' and S reservoirs and the voltage V_2 between the superconductors. The results of measurements are presented in Fig.2. The solid line represents Josephson-like effects in the S/N/S structure with the dangling arm. The potential difference between superconductors is equal to zero when the current is less than critical I_{cr} (solid line) despite the finite potential difference between the crossing point and superconductors (dashed line). As we mentioned before, the quasiparticle current I splits into two currents I_{qp1} and I_{qp2} at the crossing point flowing towards superconductors. The supercurrent I_s , equal to the quasiparticle current I_{qp2} , flows between superconductors in the opposite direction to I_{qp2} . In other words, when the current I is passed from N to S, the phase difference adjusts in such a way that the potential difference between the superconductors and net current through the dangling arm are equal to zero. This means that the quasiparticle current in the horizontal N wire creates the condensate current in the vertical N wire. We would like to stress that contrary to the case of the conventional dc Josephson effect, the electric potential along the vertical N wire is not constant, but decreases from a maximum at the crossing point to zero at the superconductors due to the quasiparticle current. The dotted line of Fig.2 represents the current-voltage characteristic of S/N/S' junction measured in a conventional way, when current is passed between superconductors (S and S') and voltage V_2 (see Fig.1) is measured. The critical current $I_c|_{V_N=0}$ (dotted line) is less than I_{cr} (solid line).

Here we present results of the analysis based on a microscopic theory. This analysis qualitatively confirms the main features of the phenomenological approach given

above. We use the well developed quasiclassical Green's function technique. (The application of this technique to the study of transport in S/N mesoscopic structures is reviewed, for example, in¹⁸.) We consider the diffusive limit and restrict ourselves to the consideration of the dc case ($V_S = 0$). We solve equations for distribution functions f_\pm which describe the symmetric and antisymmetric parts of population of the electron and hole-like branches of the quasiparticle spectrum. In the one-dimensional model assumed by us, these equations can be solved exactly and formulae for the potential V_N and current I can be written in terms of the retarded (advanced) Green's functions $\hat{F}^{R(A)}$ which obey the Usadel equation. In the general case these formulae are rather cumbersome. Here we present expressions for the currents in the simplest case when the S/N interface resistance $R_{S/N}$ is larger than the resistance of the normal wire $R_{S/N} = 1/(\sigma L_S)$. In this case, excluding V_0 we obtain for the current I_2 .

$$I_2 = I_c \sin \varphi + I_+ + I_- \cos \varphi \quad (6)$$

Where I_2 is the current in the upper vertical arm. All the functions depend on V_N and have the form

$$I_\pm = (eR_{S/N})^{-1} \int_0^\infty d\varepsilon [Im(F_S)Im(F_S T_\pm/\theta_S) f_{eq\pm}], \quad (7)$$

$$I_c = (eR_{S/N})^{-1} \int_0^\infty d\varepsilon [Im(F_S)Re(F_S T_-/\theta_S) f_{eq+} + Re(F_S)Im(F_S T_-/\theta_S) f_{eq}], \quad (8)$$

where $F_S = \Delta/\sqrt{(\varepsilon + i\gamma)^2 - \Delta^2}$ is the retarded Green's function in the superconductors, $T_\pm = \tanh \theta \pm \tanh \theta_S$, $\theta = \theta_S + \theta_N$, $\theta_{S,N} = \sqrt{-2i\varepsilon/\varepsilon_{S,N}}$, $\varepsilon_{S,N} = D\hbar/L_{S,N}^2$ is the Thouless energy, $f_{eq} = \tanh(\varepsilon/2k_B T)$, $f_{eq\pm} = [\tanh((\varepsilon + eV_N)/2k_B T) \pm \tanh((\varepsilon - eV_N)/2k_B T)]/2$ are the distribution functions in the N reservoir. For the current in the lower vertical arm we have the same expression with opposite quasiparticle current $I_1 = I_c \sin \varphi - (I_+ + I_- \cos \varphi)$. The critical voltage is determined from the equation $I_1 = -I_+ + \sqrt{I_c^2 + I_-^2} \sin(\varphi + \theta) = 0$ as a maximum value of V_N for which a solution of this equation for φ exists (we note that I_+ increases with increasing V_N), where $\cos \theta = I_c/\sqrt{I_c^2 + I_-^2}$. We find $I_+(V_{cr}) = \sqrt{I_c^2(V_{cr}) + I_-^2(V_{cr})}$ and the critical current is

$$I_{cr} = 2I_c^2(V_{cr})/\sqrt{I_c^2(V_{cr}) + I_-^2(V_{cr})}. \quad (9)$$

The critical current corresponds to the phase difference φ_c determined by the relation:

$$\sin \varphi_c = I_c(V_{cr})/\sqrt{I_c^2(V_{cr}) + I_-^2(V_{cr})}. \quad (10)$$

Fig.3 shows the experimental results and theoretical calculations of temperature dependence for the critical

current I_{cr} and the Josephson critical current $I_c|_{V_N=0}$. Where $\gamma = 0.1\Delta$, $\Delta(0) = 1.76k_B T_c$, $T_c = 1.4$ K, $D = 140$ cm²/s and $R_{S/N} = 3.75$ Ω . The diffusion coefficient and the interface resistance estimated from resistance measurement were 124 cm²/s and 0.7 Ω respectively. The discrepancy of fitting parameters and estimated values can be attributed to the fact that in our samples $R_S \cong R_{S/N}$, while in our model interface resistance dominates over sample resistance. Nevertheless the theoretical curves show qualitatively the same behavior as the experimental ones. We note that these formulae are a good approximation even if $R_S \cong R_{S/N}$. We plot a guideline $I^* = 2I_c|_{V_N=0}$ for comparison. At temperatures below 500 mK, I_{cr} deviates from I^* . There are two reasons for that: first, the reduction of the critical current I_{cr} by the voltage V_N ; second, the reduction of resistances R_h , $R_{1,2}$ related to the proximity effect. The latter means that the phase difference which corresponds to I_{cr} does not reach $\pi/2$ ($\varphi_c < \pi/2$) (see eq. 3,10). At high temperatures the curves coincide $I_{cr} \cong I^*$ since both corrections are negligible.

The S/N/S junction we have studied could be driven to the π -state by additional bias voltage applied between normal reservoirs N and N' (see V_{contr} of Fig.1). At a certain value of the bias, the current-phase relationship changes in such a way that at zero current, phase difference is equal to π^7 due to the change in the electron distribution function. It turns out that Josephson-like effects can be observed in an S/N/S junction driven to π -state, with no current through one S/N interface. First we performed measurements similar to ones reported in Ref.⁷. We measured the I - V curves of S/N/S junction with additional bias voltage V_{contr} applied between normal reservoirs N and N'. The dependence of critical current $I_c(V_{contr})$ was similar to the one observed by Baselmans et al. The critical current decreased with increasing V_{contr} and disappeared at $V_{contr}^* = 180$ μ V. It reappeared again at higher voltages reaching a maximum value at $V_{contr}^{**} = 288$ μ V (see Fig.4 circles). To ensure the change of phase-current relationship at V_{contr}^* we measured the resistance of the horizontal wire depending on current flowing through the S/N/S junction. At additional bias voltages less than V_{contr}^* the resistance had a minimum at zero current, while at additional bias voltages more than V_{contr}^* it had a maximum. We then performed measurements as follows. We passed a current between N and S measuring the potential difference between superconductors S and S'. Additional voltage bias V_{contr} was applied between normal reservoirs N and N'. The dependence of the critical current $I_{cr}(V_{contr})$ was similar to $I_c(V_{contr})$ (See Fig.4 squares). We plot current-voltage characteristics at V_{contr}^{**} on the insert to Fig.4. We can conclude that despite different current-phase relationship for π -junction, the qualitative picture of current distribution remains the same: the quasiparticle current in the dangling arm is compensated by the supercurrent and the potential difference between superconductors is equal to zero.

In summary, we have studied the Josephson-like effects in an Al/Ag mesoscopic structure with a dangling superconducting arm. Experimental data on currents are in qualitative agreement with theoretical results. The study of this effect may yield additional information on the relaxation mechanism of the distribution function and reveal new peculiarities on the $I(V_N)$ curve at voltages larger than the critical voltage V_{cr} .

We would like to thank V.Shumeiko for useful discussions. One of the authors (AFV) is grateful to NEDO for the financial support and to Prof. H.Takayanagi for hospitality. We acknowledge the financial support of the NEDO International Joint Research Grant. VTP acknowledges financial support from the EPSRC (Grant No. GR/L94611).

-
- ¹ V.T. Petrashov, V.N. Antonov, P. Delsing, and T. Claeson, Phys. Rev. Lett. **70**, 347, (1993); Phys. Rev. Lett. **74**, 5268 (1995). V.T. Petrashov, Proc. of 21st Intern. Conf. on Low Temp. Physics; Czechosl. Journ. of Phys. **46**, 3303 (1996).
 - ² P.G.N. Vegvar, T.A. Fulton, W.H. Mallison, and R.E. Miller, Phys. Rev. Lett. **73**, 1416 (1994).
 - ³ H. Pothier, S. Gueron, D. Esteve, and M.H. Devoret, Phys. Rev. Lett. **73**, 2488 (1994).
 - ⁴ H. Courtois, Ph. Gandit, D. Mailly, and B. Pannetier, Phys. Rev. Lett. **76**, 130 (1996); P. Charlat, H. Courtois, Ph. Gandit, D. Mailly, A.F. Volkov, and B. Pannetier, Phys. Rev. Lett. **77**, 4950 (1996).
 - ⁵ S.G. den Hartog, B.J. van Wees, Yu.V. Nazarov, T.M. Klapwijk, Phys. Rev. **B 56**, 13738 (1997).
 - ⁶ V. Antonov and H. Takayanagi, Phys. Rev. **B 56**, R8515 (1997)
 - ⁷ J.J. Baselmans, A.F. Morpurgo, T.M. Klapwijk and B.J. van Wees Nature **397**, 43 (1999).
 - ⁸ B.J. Van Wees, K.-M. H. Lenssen, C.J.P.M. Harmans, Phys. Rev. **B 44**, 470 (1991).
 - ⁹ G. Wendin, V. S. Shumeiko, J. of Physics and Chemistry of Solids **65**, 1773 (1995), Phys. Rev. **B 53**, R6006 (1996), Superlattices and Microstructures **25**, 983 (1999).
 - ¹⁰ Li-Fu Chang and P.F. Bagwell, Phys. Rev. **B 55**, 12678 (1997)
 - ¹¹ A.F. Volkov, Phys. Rev. Lett. **74**, 4730 (1995); JETP Lett, **61**, 565 (1995);
 - ¹² A.F. Volkov and H.Takayanagi, Phys. Rev. **B 56**, 11184 (1997).
 - ¹³ S.K. Yip, Phys. Rev. **58**, 5803 (1998)
 - ¹⁴ F.K. Wilhelm, G. Schoen and A.D. Zaikin, Phys. Rev. Lett. **81**, 1682 (1998).
 - ¹⁵ J.Kutchinsky et al. Phys. Rev. Lett. **83**, 4856 (1999).
 - ¹⁶ A.F.Volkov and V.V.Pavlovskii, JETP Lett. **64**, 670 (1996), R.Seviour and A.F.Volkov, Phys. Rev **B 61**, R9273 (2000)
 - ¹⁷ S.Gueron, Th'ese de Doctorat de l'Universit'e Paris 6, 1997
 - ¹⁸ C.J. Lambert and R. Raimondi, J. Phys. Cond. Matter **10**,

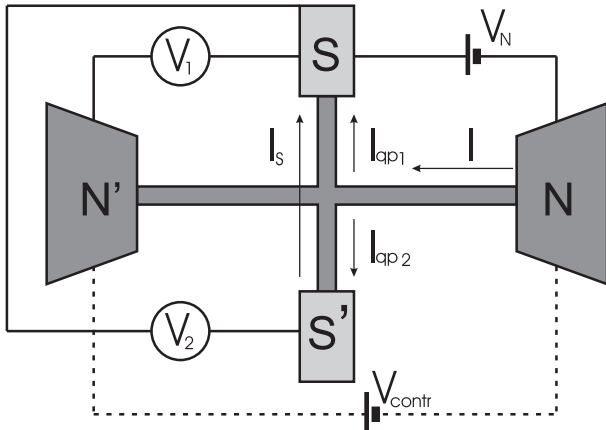

FIG. 1. Sample and measurement circuit schematic. S,S' and N,N' are superconducting and normal reservoirs. Arrows show currents: $I = I_{qp1} + I_s$, $I_s = -I_{qp2}$.

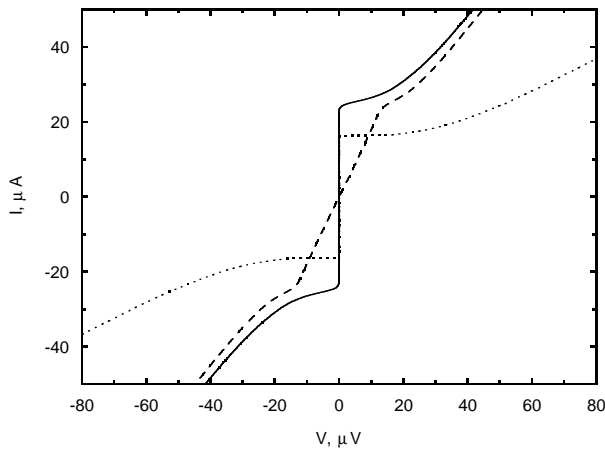

FIG. 2. Current-voltage characteristics of S/N/S structure with dangling arm. Measurement current is passed between reservoirs N and S for solid and dashed lines. Solid line corresponds to the voltage V_2 measured between superconductors S and S'. Dashed line corresponds to the voltage V_1 measured between reservoirs N' and S (See Fig.1). Dotted line represents an experimental I - V curve of S/N/S' junction.

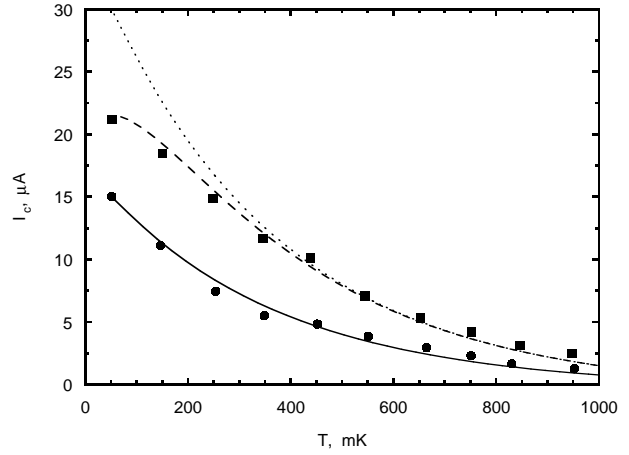

FIG. 3. Experimental and theoretical temperature dependencies of critical currents. Circles show the temperature dependence of the critical current measured in a conventional way and squares show the same dependence for the structure with a dangling arm. Calculated temperature dependencies of critical currents are shown by lines. Solid line is $I_c|_{V_N=0}$; dashed line is I_{cr} ; dotted line is guideline $I^* = 2I_c|_{V_N=0}$.

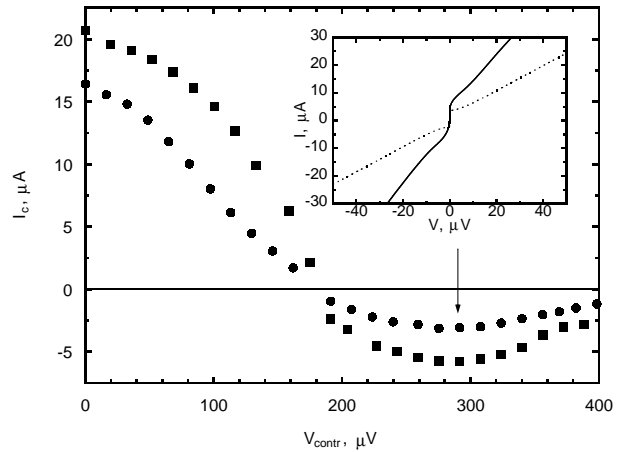

FIG. 4. Critical currents I_c and I_{cr} versus additional bias voltage applied between normal reservoirs measured at temperature 50 mK. Circles and squares show I_c and I_{cr} respectively. Inset: current-voltage characteristics measured at additional bias voltage shown by arrow. Dotted line represents the I - V curve of S/N/S' junction. Solid line corresponds to the measurement with a dangling arm.