

# Measuring Rashba spin orbit interaction strength without magnetic field

T. P. Pareek

Harisch Chandra Research Institute, Chaatnag Road, Jhansi, Allahabad - 211019, India

We propose a multi-terminal(Non-magnetic) mesoscopic electrical transport measurement for measuring Rashba spin orbit strength. The method proposed is different from the usual magneto transport measurements, which require magnetic fields for e.g. Shubnikov-de Hass oscillations or weak anti-localization measurements. Our methods uses three terminal mesoscopic device, in which one of the terminal acts as a voltage probe. We show that the Voltage measured at the non-magnetic voltage probe depends on the strength of Rashba spin-orbit interaction.

PACS numbers: 72.25-b,72.25.Dc, 72.25.Mk

A central theme of spintronics research is to realize Datta-Das spin field effect transistor(Spin-FET) or its equivalent which would allow manipulation of spin at mesoscopic level[1]. Datta-Das Spin-FET relies on the Rashba spin-orbit interaction which can be controlled by applying a gate voltage [2]. Accordingly it is know as gate controlled spin-orbit interaction. The key idea is application of gate voltage on the top of device causes changes in asymmetry of confining potential and hence controls Rashba-spin-orbit (RSO) interaction which is dependant on the interface electric field. This gate control of RSO interaction have been experimentally verified in many two dimensional narrow gap III-IV semiconductor heterostructures for e. g. in InAs/AlSb [3], in GaSb-InAs-GaSb quantum wells [4] and in  $\text{In}_x\text{Ga}_{1-x}\text{As}/\text{In}_{0.52}\text{Al}_{0.48}\text{As}$  heterostructures by Nitta and Das *et al.* [5]. Experimentally, Shubnikov-de Hass (SdH) oscillation are measured as a function of magnetic field and applied gate voltage. Zero field spin splitting manifest itself as a beating pattern in SdH oscillation due to two close frequency components with similar amplitudes arising from spin-split levels. The spin splitting at zero field is extracted from finite field data by linear extrapolation [7]. However due to finite magnetic field, Zeeman splitting is always present which makes it ambiguous to extract the spin orbit parameter. Further the top gate voltage also changes the concentration of charge carriers in spin sub bands. This affects the beating pattern in SdH oscillation which crucially depends on the difference of carrier concentration between tow spin sub-bands. In-fact SdH oscillations vanishes for higher values of top gate voltage, since the carrier concentration in the channel saturate without filling the second sub-band [8]. The spin-orbit coupling parameter thus can not be extracted beyond a certain gate voltage. Hence the measurement of Rashba spin-orbit parameter with SdH oscillation is not free of ambiguities as was pointed out recently [9],[10] [11].

In light of above discussion, it is clear that it would be interesting and highly desirable if one can design an experiment which would allow to measure the spin-orbit parameter with out the application of magnetic field. We propose and show in this letter that mesoscopic multi-terminal charge transport measurement provides such a way to measure sin-orbit interaction. To under-

stand our proposal we recapitulate briefly the generalized Landauer-Büttiker theory for multi-terminal spin-charge transport developed by us recently [12]. For spin quantization axis to be along  $\hat{\mathbf{u}}$ , pointing along  $(\theta, \phi)$  where  $\theta$  and  $\phi$  are usual spherical angles, the net spin and charge currents flowing through terminal  $m$  are given by;

$$I_m^q = I_m^\sigma + I_m^{-\sigma} \equiv \frac{e^2}{h} \sum_{n \neq m, \sigma, \alpha} \{(T_{nm}^{\alpha\sigma} V_m - T_{mn}^{\sigma\alpha} V_n)\} \quad (1)$$

$$\begin{aligned} I_m^s &= I_m^\sigma - I_m^{-\sigma} \\ &\equiv \frac{e^2}{h} \sum_{n \neq m, \alpha} \{(T_{nm}^{\alpha\sigma} - T_{nm}^{\alpha-\sigma})V_m + (T_{mn}^{-\sigma\alpha} - T_{mn}^{\sigma\alpha})V_n\} \end{aligned} \quad (2)$$

where  $I_m^q$  is charge current and  $I_m^s$  is spin current flowing in terminal  $m$ .  $T_{nm}^{\alpha\sigma}$  are spin resolved transmission coefficients from terminal  $m$  to  $n$  and  $V_m$  is applied potential at terminal  $m$ .

Now let us consider the special case where the voltages at terminal 1 and 2 are respectively  $V_1=0$  and  $V_2$  and terminal third is a voltage probe, i.e,  $I_3^q = 0$  (see Fig.1, here we would like to stress that we consider a Y shaped three terminal conductor since it is symmetric with 120 deg rotation hence the effect due to geometrical asymmetry would be minimized which will not be the case if one considers other three terminal geometries for, e.g., a T shaped conductor). With this condition one can determine the voltage,  $V_3$ , at third terminal using the set of equation (1) and is given by [13],

$$\frac{V_3}{V_2} = \frac{T_{32}}{T_{13} + T_{23}} \quad (3)$$

where  $T_{nm}$  are total transmission coefficient (summed over spin indices) from terminal  $m$  to  $n$ .

It is know from studies in mesoscopic physics that the presence of third lead can change the conductance, since it acts as a scatterer[13]. Hence in similar way if the scattering is changed within the sample that should also reflect in three terminal measurement. This is seen clearly from (3) that the voltage  $V_3$  at third non-magnetic terminal depends on the ratio of transmission coefficients  $T_{32}$

and  $T_{13} + T_{23}$ . Presence of spin-orbit interaction does lead to spin conserved and spin flip scattering which in turn changes spin resolved transmission coefficient  $T_{nm}^{\alpha,\sigma}$ , and , hence the total transmission coefficient. Accordingly the voltage  $V_3$  at third terminal will show changes as one varies spin-orbit interaction strength through top gate voltage. **In other words  $V_3$  will show dependence on the gate voltage.** So by calibrating these changes one can extract the Rashba spin-orbit parameter. We would like to stress that we do not need to apply magnetic field which is the case for SdH oscillation as well for weak localization measurement. Hence this method will not have the difficulties which was the case for other methods as discusses in introduction.

Here we would like to point out that In Ref.[12] we had studied the problem of how to measure the spin currents when terminal third is Ferromagnetic. Third terminal being Ferromagnetic selectively allowed electrons whose spins were parallel to the magnetization of lead, and, hence it was sensitive to the spin currents flowing. Further in ref. [12] spin currents and corresponding voltage were studied as a function of quantization axis for a fixed spin-orbit interaction strength. Since the origin of spin-orbit interaction was due to presence of impurity which is fixed for a given sample and can not be changed. While Rashba interaction can be changed through an external gate voltage, which is the topic of study in present manuscript. Further in this article all leads are non-magnetic and there is no magnetic filed either. Since we are interested in the strength of spin-orbit interaction which depends on the ratio of total transmission coefficient in different leads.Hence in present study topic of investigation is charge transport when all the leads are non-magnetic and how can one use it to measure strength of spin-orbit interaction which is easier to measure experimentally as well is different from spin current study as was done in Ref. [12]. Since leads are non-magnetic they are insensitive to different component of spin currents in other words even though the spin currents flowing across  $x$ ,  $y$  and  $z$  axis will be different but the voltage measured at third lead will be same and measures the strength of spin-orbit interaction.

To obtain quantitative results we perform numerical simulation on a Y-shaped conductor shown in Fig. 1(we have discussed above that Y-shaped conductor being most symmetric among the three terminal devices which would minimized any spurious results due to geometrical asymmetry). We model the conductor on a square tight binding lattice[14] with lattice spacing  $a$  and we use the corresponding tight binding model including Rashba spin orbit interaction given by

$$H_{Rashba} = \alpha(\sigma_x k_y - \sigma_y k_x) \quad (4)$$

where  $\sigma$ 's are Pauli matrices and  $k_x$  and  $k_y$  are momentum vector along  $x$  and  $y$  axis respectively and  $\alpha$  is Rashba spin-orbit interaction parameter. For the calculation of spin resolved transmission coefficient , we use the recursive green function method. Details of this can be

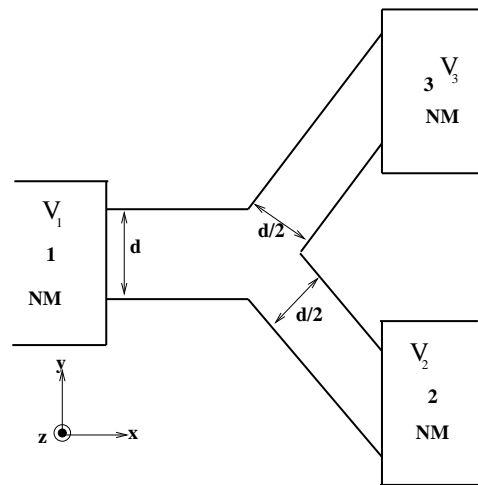

FIG. 1: Y-shaped three terminal junction with applied voltages  $V_1$ ,  $V_2$  and  $V_3$  as depicted. Terminal third (labeled 3) is a voltage probe and draws no charge current . All three terminals are non-magnetic.

found in Ref.[14]. The numerical result presented takes the quantum effect and multiple scattering into account and is exact at the single particle level. For the model of disorder we take Anderson model, where on-site energies are distributed randomly within  $[-U/2, U/2]$ , where  $U$  is the width of distribution.

To present quantitative results we measure energy in units of hopping parameter  $t$  for tight binding model, we set it equal to 1 above the band bottom. Dimensionless Rashba coupling is defined as  $\lambda_{rso} = \alpha/2*t*\lambda_f$ , where  $\lambda_f$  is Fermi energy. Experimentally observed values of these parameters are are  $E_f \approx 80 - 120meV$ , corresponding  $\lambda_f \approx 70 - 200A^\circ$  and the RSO coupling  $\alpha$  varies between  $0.4 \times 10^{-11}eV - m$  to  $1.2 \times 10^{-11}eV - m$  [3, 4, 5, 6]. Accordingly our dimensionless Rashba coupling parameter  $\lambda_{rso}$  varies between 0.005 to 0.04. In our numerical simulation we have varied  $\lambda_{rso}$  upto 0.05.

In Fig.2 we show charge current( $I_q^1 = -I_q^2$  flowing between terminal one and two and voltage at the third terminal (which is voltage probe, i.e., $I_q^3 = 0$ ) for ballistic system. We see that varies as spin orbit coupling is varied. Since the system is ballistic , hence the scattering occurs only due to spin-orbit interaction and accordingly the  $V_3/V_2$  and  $I_q^1$  shows variation. We notice that both charge current and voltage depends quadratically on the spin-orbit coupling strength  $\lambda_{rso}$ . This is expected since only non zero scattering matrix element due to RSO are of second order in perturbation theory. Hence we see that in a three terminal geometry one can extract Rashba parameter just by measuring charge current or equivalently voltage. We stress that in two terminal though the conductance will show variation as a function of Rashba parameter , but these variation will be overshadowed due

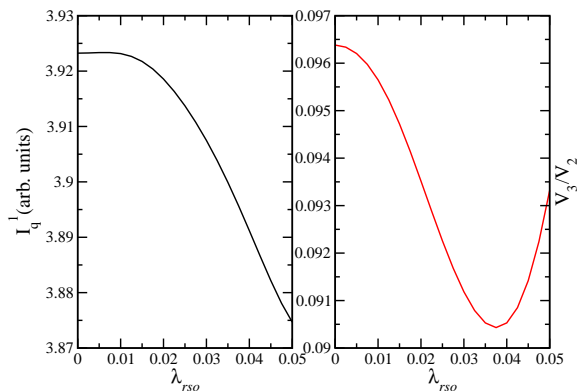

FIG. 2: Charge current and voltage versus spin-orbit interaction strength  $\lambda_{rso}$  for  $E_f=1.0t$  and  $U=2.0t$ .

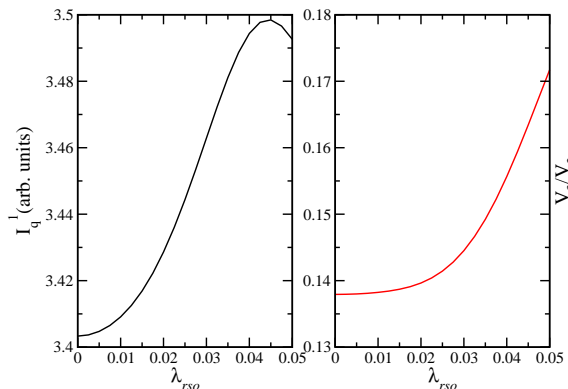

FIG. 3: Charge current and voltage versus spin-orbit interaction strength  $\lambda_{rso}$  for  $E_f=1.0t$  and  $U=0.5t$ .

to beating pattern arising out of band mismatch at the contact between reservoirs and the system, which give rise to potential well at the contacts. Due to multiple reflections in this potential well the conductance will show beating pattern arising out of interference between two Rashba split spin sub-bands [17]. Hence a two terminal measurement will suffer from the same difficulties and ambiguities as was the case for SdH oscillation. Therefore a three terminal measurement is necessary and useful.

In Fig. 3, Fig. 4 and Fig. 5 we present results for diffusive regime corresponding to Anderson disorder strength  $U=0.5t$ ,  $1t$  and  $2t$ , respectively. For a given sample since disorder strength is fixed hence variations in charge current and voltages are just due to change in RSO strength as is seen in the Figures. However for large values of  $\lambda_{rso}$  there are qualitative changes between voltages and currents. This is so since we have not performed disorder average, hence for a given distribution asymmetry is introduced between different branches of Y-shaped conductor, which reflects in the qualitative difference between voltages and charge current. The asymmetry introduced for a given distribution of impurities can be reduced by per-

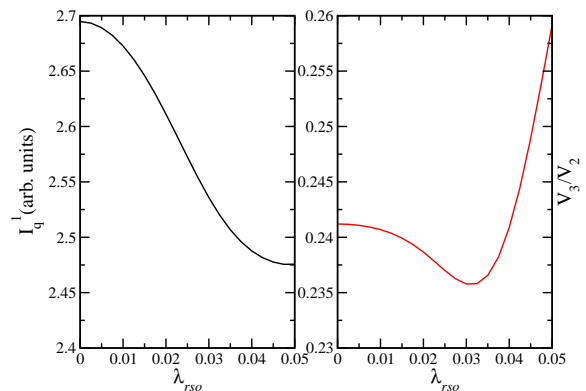

FIG. 4: Charge current and voltage versus spin-orbit interaction strength  $\lambda_{rso}$  for  $E_f=1.0t$  and  $U=1.0t$ .

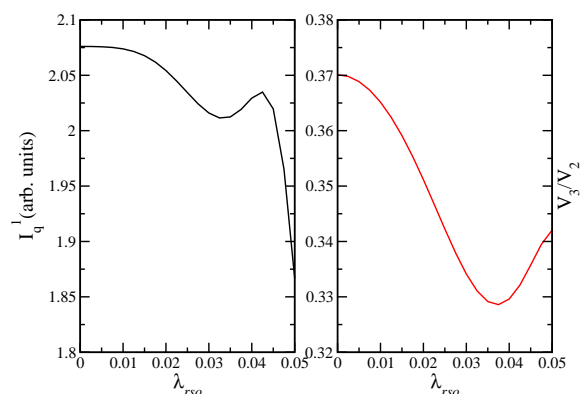

FIG. 5: Charge current and voltage versus spin-orbit interaction strength  $\lambda_{rso}$  for  $E_f=1.0t$  and  $U=2.0t$ .

forming disorder averages and hence the RSO strength can be calibrated for diffusive case as well.

Finally we discuss about the observability of this effect. We see that for experimentally accessible regime of  $\lambda_{rso}$  the current and voltage changes respectively by 60% and 10%. These changes are large enough to be observable in experiments. Further since changes in current  $I_q^1$  is an order of magnitude larger compared to the changes in voltage, hence through charge measurement it will be easier to observe this effect and correspondingly measure Rashba spin orbit interaction strength.

In conclusion we have proposed and shown that Rashba spin orbit interaction can be measured in absence of magnetic field just by measuring charge current or voltages in a three terminal mesoscopic device. We have discussed advantages of this method over the standard SdH oscillation measurement for which applied magnetic field is essential. Further the effect for charge current is of the order of 60% and for voltage it is of the order of 10%.

Hence by just measuring charge current in a three terminal mesoscopic system one can extract Rashba spin orbit

interaction strength. We hope that this will open up new opportunities in the field of spintronics.

- 
- [1] S. Datta and B. Das, Appl. Phys. Lett. **56**, 665(1990).  
 [2] Yu. A. Bychkov and E. I. Rashba, Sov. Phys. JETP Lett. **39**, 78 (1984).  
 [3] J. P. Heida, B. J. van Wess, T. M. Klapwijk and G. Borghs, in *Proceedings of the 23rd International conference on the Physics of semiconductors* edited by M. Scheffler and R. Zimmermann (World Scientific, Singapore, 1996) Vol. 3, pp. 2467.  
 [4] Luo, H. Munekata, F. F. Fang, and P. J. Stiles, Phys. Rev. B **38**, 10142 (1988).  
 [5] J. Nitta, T. Akazaki, H. Takayanagi and T. Enoki, Phys. Rev. Lett **78** 1335 (1997).  
 [6] B. Das, C. D. Miller, S. Datta, R. Reifenberger, W. P. Hong, P. K. . Bhattacharya, J. Singh, and M. Jaffe, Phys. Rev. B. **39**, 1411(1989).  
 [7] G. Lommer, F. Malcher, and U. Rössler, Phys. Rev. Lett. **60**, 728(1988).  
 [8] G. Engels, J. Lange, Th. Schäpers, and H. Lüth, Phys. Rev. B. **55** R1958 (1997).  
 [9] S. Keppeler and R. Winkler, Phys. Rev. Lett. **88** 046401 (2002).  
 [10] S. A. Tarasenko and N. S. Averkiev Pis'ma Zh. Exsp. Teor. Fiz. **75**, 669 (2002) [JETP Lett. **75**, 552 (2002)].  
 [11] N. S. Averkiev, M. M. Glazov and S. A. Tarasenko, cond-mat/0412021.  
 [12] T. P. Pareek, Phys. Rev. Lett. **92**, 076601 (2004).  
 [13] T. P. Pareek, Sandeep K. Joshi and A. M. Jayannavar Phys. Rev. B **57**, 8809 (1998).  
 [14] T. P. Pareek, Phys. Rev. B. **66**, 193301 (2002). T. P. Pareek and P. Bruno, Phys. Rev. B. **65**, 241305 (2002).  
 [15] G. Schmidt *et al.*, Phys. Rev. B. **64**, R121202 (2001).  
 [16] S. Datta, *Electronic transport in mesoscopic systems*, (Cambridge University press, Cambridge, 1997).  
 [17] T. P. Pareek, manuscript under preparation.  
 [18] M. Büttiker, IBM J. Res. Develop. **32** 63 (1988).