

# Supersensitive avalanche silicon drift photodetector.

Z. Ya. Sadygov\*, M. K. Suleimanov, T. Yu. Bokova  
*Joint Institute for Nuclear Research, Dubna, Russia*  
\*) *E-mail: sadygov@cv.jinr.ru*

## ABSTRACT

Physical principles of performance and main characteristics of a novel avalanche photodetector developed on the basis of MOS(metal-oxide-silicon) technology is presented. The photodetector contains a semitransparent gate electrode and a drain contact to provide a drift of multiplied charge carriers along the semiconductor surface. A high gain(more than  $10^4$ ) of photocurrent was achieved due to the local negative feedback effect realized on the  $Si - SiO_2$  boundary.

Special attention is paid to the possibilities of development of a supersensitive avalanche CCD (charge coupled device) for detection of individual photons in visible and ultraviolet spectral regions. Experimental results obtained with a two-element CCD prototype are discussed.

## INTRODUCTION

For last decades, researchers have sought solid-state alternatives to photomultiplier tubes(PMT) to be used for application in physical experiments and medical tomography. However, there is not yet any adequate solid-state analog comparable to commercial PMT to detect week light pulses consisting of a few photons at room temperature. During last years, we have investigated possibilities to made relatively cheap APDs on the basis of MRS(metal-resistive layer- semiconductor) structures fabricated on low resistive silicon wafers [1,2]. The main peculiarity of the MRS APDs is a local negative feedback (LNF) effect which results in a self-stabilized avalanche process in the semiconductor. These LNF APDs have been developed for use in red and infrared spectrum regions. Recently, we reported some characteristics of another design of LNF APD's having a high sensitivity in visible and ultraviolet spectral regions [3]. This report is devoted to physical principles of performance and main characteristics of a novel design of the LNF APD.

## DEVICE DESIGN AND PRINCIPLES OF OPERATION

The new LNF APD contains a semitransparent titanium layer (gate electrode) separated from the semiconductor surface by a silicon oxide layer and a guard-ring(drain electrode) to provide a drift of multiplied charge carriers along the  $Si - SiO_2$  boundary (see Fig.1). The titanium gate and drain electrode can be provided with individual or common(key  $K_1$  is closed) aluminum contacts for voltage supply.

Avalanche multiplication of photocurrent occurs in the p-n junction(under the gate electrode) where the breakdown potential is specially reduced due to an additional ion-implantation. The voltage applied to the LNF APD is distributed between the depletion layer of the semiconductor and the oxide layer. The hole carriers to be caused by avalanche process in a given microregion of the p-n junction is collected in a small area of the  $Si - SiO_2$  boundary, reducing the value of voltage drop in this microregion of the semiconductor. As a result each start avalanche process is self-switched in a few nanoseconds in the given microregion. A drift of the hole charge carriers from the avalanche region to the drain contact is provided by a high resistive layer during about 100 ns after switching of the given avalanche process. The parameters(thickness and surface resistivity) of this resistive layer are field-dependent, and so the LNF effect can be adjusted by the gate potential. Such character of avalanche process is called the local negative feedback effect.

## MAIN PECULIARITIES OF DEVICE PERFORMANCE

Fig.2 shows the measured gain of photocurrent versus negative bias on the drain electrode. The LNF APD sample had a photosensitive area of 1mm diameter. An initial pulsed photocurrent with a duration of 0.4ms and an amplitude of 6nA was used in these measurements. One can see that the character of avalanche process in the LNF APD is fully defined by the gate potential. At fixed gate biases, a situation can be achieved where gain becomes independent of drain potential. This peculiarity of the tested device indicates the unique possibility of building multichannel avalanche photodetectors with a high spatial uniformity of gain.

Another type of operation of this device is connected with a pulsed third level supply of the gate electrode (for example,  $V_g = -69.5V, -55V, -45V$  at  $V_d = -63V = \text{const}$ ). Under these conditions, a CCD (charge coupled device) type performance of the LNF APD was realized. A high gain of about  $10^4$  was obtained. A light emitted diode with a wavelength of 450nm and a pulse duration of 50ns was used as a signal for detection.

The amplitude distributions of the signals detected by the LNF APD are presented in Fig.3 for light pulses which contain one photon in average. The photomultiplier FEU-130 (made in Russia) was used to count the average number of photons in light pulses. One can see that a single photon detection mode with a high efficiency was realized at room temperature. If we take the threshold amplitude equal to the 150-th channel, then the detection efficiency of the LNF APD is about 25%.

#### PERSPECTIVES

As shown above there are real possibilities of development of a super sensitive multichannel photodetectors as well as an avalanche type CCD for single photon detection in visible and ultraviolet spectrum regions. To our mind, these unique properties of the presented LNF APDs would be good prospects for future applications in high energy physics, high speed photonics and medical tomography.

#### REFERENCES

1. Z.Sadygov et.al. Proc. SPIE- The Intern. Soc. for Opt. Eng., 1621, (1991), 158-168.
2. Z.Sadygov et.al. IEEE Trans. Nucl.Sci., 43, 3, (1996), 1009-1013.
3. Z.Sadygov. Russian patent N2086027, application of May 30-th, 1996.
4. N.Bacchetta, Z.Sadygov et.al.. Nucl.Instr.and Meth, A387, (1997), 225-230.

#### FIGURE CAPTIONS

Figure 1. Simplified structure of the LNF APD. 1- thick Al electrodes; 2- semitransparent Ti gate electrode; 3- dielectric layer ( $SiO_2$ ); 4-surface drift layer; 5- p-Si layer; 6- n-Si layer with additional ion-implantation; 7- n-Si wafer; 8- p-Si guard (drain) ring.

Figure 2. Photocurrent gain as a function of drain voltage. 1-  $V_g = -68.5V = \text{const}$ ; 2-  $V_g = -69.0V = \text{const}$ ; 3-  $V_g = -69.5V = \text{const}$ ; 4-  $V_g = V_d$  (key  $K_1$  is closed).

Figure 3. Amplitude spectrum of LNF APD output pulses. 1- dark condition; 2- single-photon mode; 3- double-photon mode

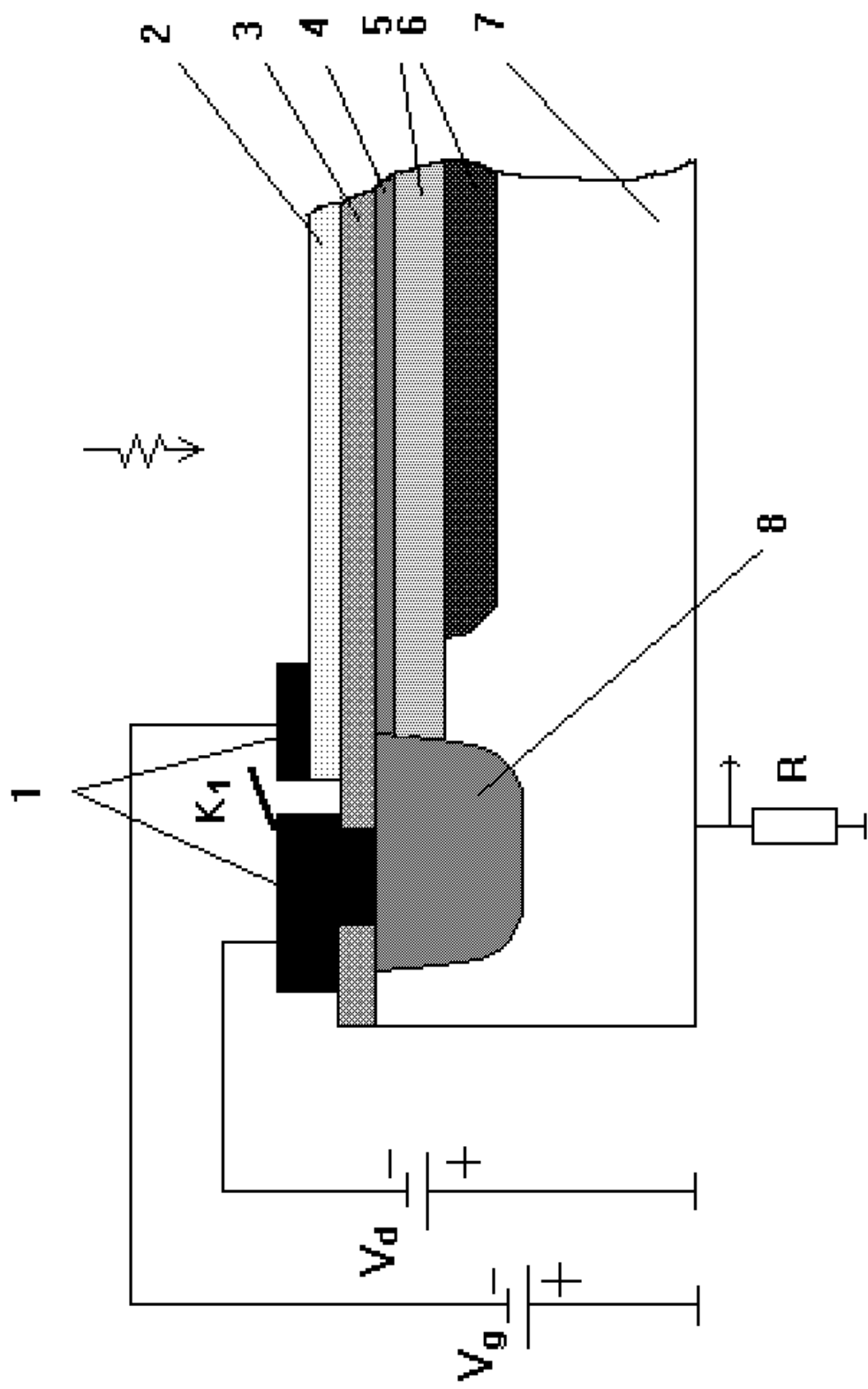

Fig. 1

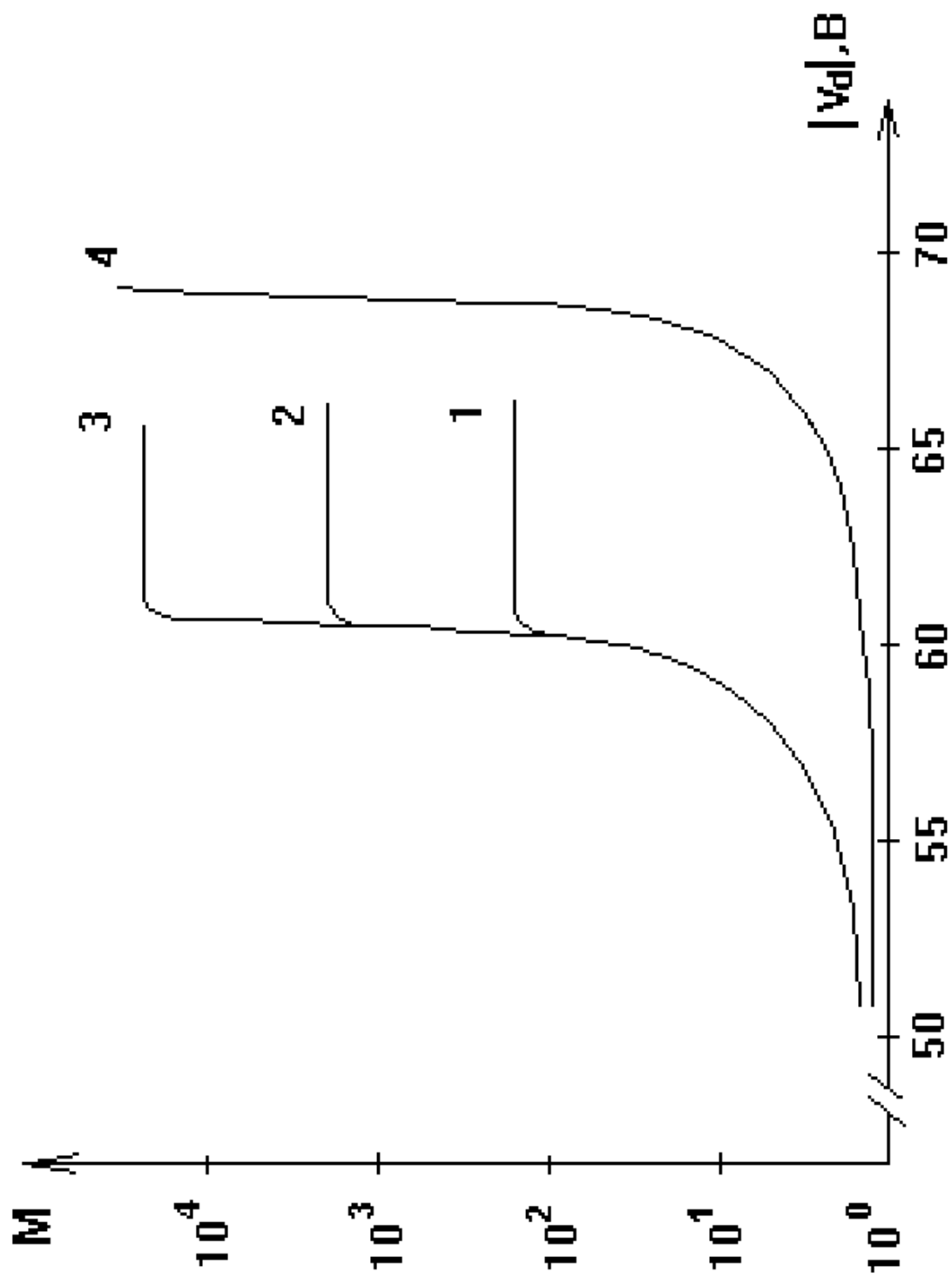

Fig. 2

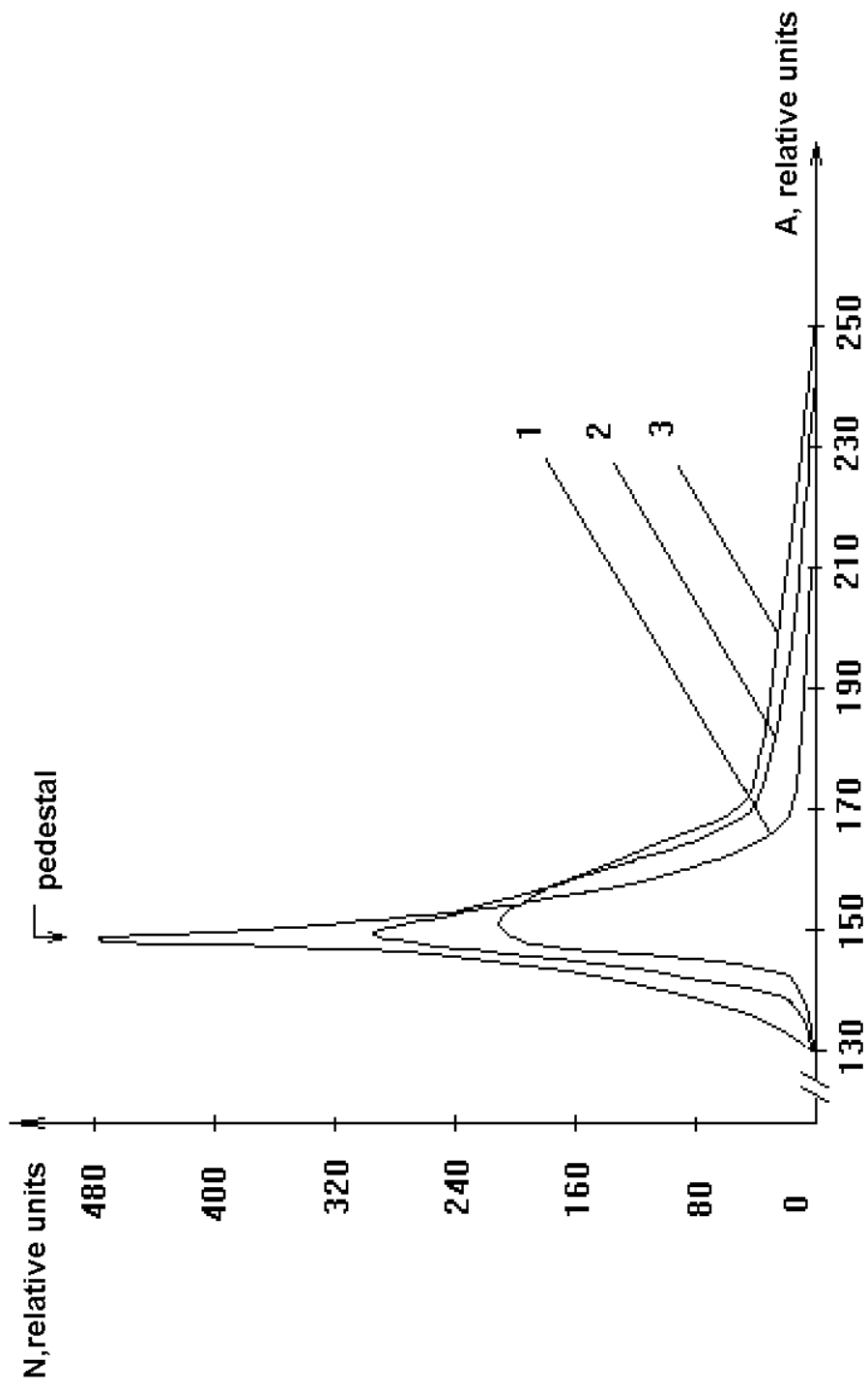

Fig. 3