

# SEIBERG-WITTEN THEORY AND RANDOM PARTITIONS

NIKITA A. NEKRASOV<sup>†1</sup>, ANDREI OKOUNKOV<sup>2</sup>

<sup>1</sup> *Institut des Hautes Etudes Scientifiques, Bures-sur-Yvette F-91440 France*

<sup>2</sup> *Department of Mathematics, Princeton University, Princeton NJ 08544 USA*

We study  $\mathcal{N} = 2$  supersymmetric four dimensional gauge theories, in a certain  $\mathcal{N} = 2$  supergravity background, called  $\Omega$ -background. The partition function of the theory in the  $\Omega$ -background can be calculated explicitly. We investigate various representations for this partition function: a statistical sum over random partitions, a partition function of the ensemble of random curves, a free fermion correlator.

These representations allow to derive rigorously the Seiberg-Witten geometry, the curves, the differentials, and the prepotential.

We study pure  $\mathcal{N} = 2$  theory, as well as the theory with matter hypermultiplets in the fundamental or adjoint representations, and the five dimensional theory compactified on a circle.

June 2003

---

<sup>†</sup> On leave of absence from: ITEP, Moscow, 117259, Russia

## TABLE OF CONTENTS

1.	INTRODUCTION . . . . .	3
1.1.	<i>Notations</i> . . . . .	3
1.2.	<i>Organization of the paper</i> . . . . .	4
1.3.	<i>Acknowledgments</i> . . . . .	5
2.	$\mathcal{N} = 2$ GAUGE THEORY, DEFORMATIONS AND BACKGROUNDS . . . . .	6
2.1.	<i>Lagrangian, fields, couplings</i> . . . . .	6
2.2.	$\Omega$ -background . . . . .	7
2.2.1.	$\Omega$ -background in the physical formalism . . . . .	7
2.2.2.	$\Omega$ -background in the twisted formalism . . . . .	8
2.3.	<i>On supersymmetry</i> . . . . .	9
2.3.1.	Supersymmetry of the physical theory . . . . .	9
2.3.2.	Twisted superalgebra . . . . .	9
2.3.3.	Supersymmetry of the $\Omega$ -background . . . . .	10
2.4.	<i>Noncommutative deformation</i> . . . . .	11
2.4.1.	Combining $\Omega$ and $\Theta$ . . . . .	13
2.4.2.	Supersymmetry of the noncommutative theory in $\Omega$ background . . . . .	14
2.4.3.	Observables in the supersymmetric gauge theory: $\Omega = 0$ . . . . .	14
2.4.4.	Observables: $\Omega \neq 0$ . . . . .	15
3.	GAUGE THEORY PARTITION FUNCTION . . . . .	17
3.1.	<i>Partition function as a sum over partitions</i> . . . . .	18
3.2.	<i>Plancherel measure on partitions</i> . . . . .	20
4.	PREPOTENTIAL . . . . .	22
4.1.	<i>Quasiclassical limit and SW curve</i> . . . . .	22
4.2.	<i>Partitions and their profiles</i> . . . . .	25
4.3.	<i>Vacuum expectation values and resolvents</i> . . . . .	27
4.4.	<i>Real vs. complex</i> . . . . .	28
4.5.	<i>The thermodynamic limit</i> . . . . .	28
4.5.1.	Profiles vs. eigenvalue densities . . . . .	30
4.5.2.	Surface tension . . . . .	32
4.6.	<i>The equations for the limiting shape</i> . . . . .	33
4.7.	<i>Construction of the maximizer</i> . . . . .	35
4.7.1.	Construction of the conformal map . . . . .	35
4.7.2.	Example: $N = 2$ . . . . .	36
4.7.3.	Gaps and bands . . . . .	37
4.7.4.	Periods . . . . .	39
4.7.5.	Completeness . . . . .	40
4.7.6.	Periods and the prepotential . . . . .	41
4.8.	<i>Lax operator</i> . . . . .	42
4.9.	<i>An <math>SU(3)</math> example</i> . . . . .	43
4.10.	<i>Higher Casimirs</i> . . . . .	44
5.	DUAL PARTITION FUNCTION AND CHIRAL FERMIONS . . . . .	46
5.1.	<i>Dual partition function</i> . . . . .	46
5.2.	<i>Free fermions</i> . . . . .	47

5.2.1.	<i>Bosonization</i>	49
5.3.	<i>Dual partition function as a current correlator</i>	49
5.4.	<i>Affine algebras and arbitrary gauge groups</i>	50
5.5.	<i>Dual partition function and <math>\mathfrak{gl}(\infty)</math></i>	50
5.6.	<i>The <math>U(1)</math> case</i>	51
6.	<b><math>\mathcal{N} = 2</math> THEORY WITH ADJOINT HYPERMULTIPLY</b>	<b>53</b>
6.1.	<i>Partition function</i>	53
6.2.	<i>Abelian theory</i>	54
6.2.1.	<i>Higher Casimirs and Gromov-Witten theory of elliptic curve</i>	56
6.3.	<i>Nonabelian case</i>	56
6.4.	<i>Path representation</i>	57
6.5.	<i>Variational problem for the prepotential</i>	57
6.5.1.	<i>Path energy and surface tension</i>	57
6.5.2.	<i>Variational equations</i>	58
6.6.	<i>The spectral curve</i>	59
6.6.1.	<i>Periods</i>	62
7.	<b>ON ANOTHER MATTER</b>	<b>64</b>
7.1.	<i>Hypermultiplets in the fundamental representation</i>	64
7.2.	<i>Five dimensional theory on a circle</i>	67
7.2.1.	<i>Path representation</i>	68
7.2.2.	<i>Prepotential</i>	68
7.2.3.	<i>Free field representation</i>	71
8.	<b>CONCLUSIONS AND FUTURE DIRECTIONS</b>	<b>72</b>
8.1.	<i>Future directions and related work</i>	72
8.2.	<i>Summary of the results</i>	77
<b>Appendix A.</b>	<b>The function <math>\gamma_{\hbar}(x; \Lambda)</math></b>	<b>78</b>
A.0.1.	<i>Free case: <math>\epsilon_2 = -\epsilon_1 = \hbar</math></i>	78
A.0.2.	<i>Anyon case: general <math>\epsilon_1, \epsilon_2</math></i>	79
A.0.3.	<i>Trigonometric analogue of <math>\gamma_{\epsilon_1, \epsilon_2}(x; \Lambda)</math></i>	80
<b>Appendix B.</b>	<b>Partitions, charges, colours</b>	<b>81</b>
B.0.4.	<i>Power-sums</i>	82
<b>Appendix C.</b>	<b>Theta-function</b>	<b>84</b>

## 1. INTRODUCTION

Supersymmetric gauge theories are interesting theoretical laboratories. They are rich enough to exhibit most of the quantum field theory phenomena, yet they are rigid enough to contain a lot of exactly calculable information [1][2][3][4]. They embed easily into string theory, and provide an exciting arena for the search of string/gauge dualities [5][6][7][8].

In the past year a lot of progress has been made in understanding some of this rich structure using direct field theoretic techniques ([9][10] and refs therein), in the case of the theories with extended supersymmetry, and in [8] in the case of  $\mathcal{N} = 2$  susy broken down to  $\mathcal{N} = 1$  by the superpotential.

In particular, a connection between four dimensional gauge theories and two dimensional conformal field theories seemed to appear. Some earlier indications for such a connection were observed in the study of  $\mathcal{N} = 4$  super-Yang-Mills theory [11][12].

In this paper we shall make this connection more transparent in the case of  $\mathcal{N} = 2$  theories.

We shall also derive, by purely field theoretic means, via direct instanton calculus, the solution for the low-energy effective theories, proposed by Seiberg and Witten in 1994 [13] and further generalized in [4][14].

### 1.1. Notations

Throughout the paper we denote the colour indices by the lower case Latin letters  $l, m, n = 1, \dots, N$ , the vevs of the Higgs field by

$$\mathbf{a} = \text{diag}(a_1, \dots, a_N), \quad a = \frac{1}{N} \sum_l a_l, \quad \tilde{a}_l = a_l - a$$

the dual vevs by

$$\xi = \text{diag}(\xi_1, \dots, \xi_N).$$

The vector

$$\rho_l = \frac{1}{N} \left( l - \frac{N+1}{2} \right)$$

will occur often.

The gauge group  $G = U(N)$ , the group of gauge transformations on  $\mathbf{R}^4$  which extend smoothly to  $\mathbf{S}^4$  will be denoted by  $\mathcal{G}$ . Its normal subgroup  $\mathcal{G}_\infty$ , which consists of the gauge transformations, trivial at  $\infty$ , will play a special rôle.

## 1.2. Organization of the paper

The section 2 is addressed at physicists, who want quickly jump onto the subject. It contains previously unpublished details on the noncommutative regularizations of the theories we consider, as well as systematic introduction into  $\Omega$ -backgrounds. In this paper we shall not touch upon the recently revived [15]  $C$ -backgrounds of [16][17], postponing the explanations of the relations between  $\Omega$  and  $C$  to some future work.

Section 3 starts setting up the stage for the mathematical problem and the reviews the ingredients needed for its solution. We present the formula for the partition function of the pure  $\mathcal{N} = 2$  gauge theory in the  $\Omega$ -background, as a sum over random partitions. We also begin to formulate the same sum in terms of random paths, which arise as the boundaries of the Young diagrams, representing the random partitions. Mathematically oriented reader can skip the section 2 and proceed directly to 3 (we also recommend [18][19] for orientation).

Section 4 attacks the problem of the calculation of the prepotential. Physically it has to do with the limit, where the  $\Omega$ -background approaches the flat space. In the random path representation, this limit is the quasiclassical limit, which can be evaluated using the saddle point method. This is exactly the idea of our derivation. We extensively discuss the equations on the minimizing path, and their solution. We find that the solution is most simply described in terms of the Seiberg-Witten curve.

Section 5 explains the fermionic representation of the partition function in the special  $\Omega$ -background, preserving twice as much supersymmetries compared to the generic  $\Omega$ -background. Even though the formalism of free fermions is well-known to mathematicians, under the name of the infinite wedge representations of  $\mathfrak{gl}(\infty)$  algebra, we supply the necessary details. We find that a certain transform of the partition function can be written as a matrix element (current conformal block) of the exponentials in the  $\widehat{U}(\widehat{N})$  currents on the sphere  $\mathbf{S}^2$ .

Section 6 begins our quest for generalizations. We discuss the softly broken  $\mathcal{N} = 4$  theory, i.e.  $\mathcal{N} = 2$  gauge theory with the matter hypermultiplet in the adjoint representation. As most of the steps are similar to the pure gauge theory case we move faster, and write down the expression for the partition function in terms of partitions, paths, and chiral fermions, which this time live on elliptic curve, determined by the microscopic gauge coupling. Again we perform the saddle point evaluation, and find that the prepotential is encoded, as conjectured by Donagi and Witten [20], in the spectral curves of the elliptic Calogero-Moser integrable system.

Section 7 considers gauge theories with matter in the fundamental representation, and the gauge theories with the tower of Kaluza-Klein states, coming from the compactification of the five dimensional theory on a circle.

Section 8 presents our conclusions and the discussion of the unsolved problems.

### 1.3. Acknowledgments

We thank A. Braverman, R. Kenyon, A. Losev, G. Moore, A. Morozov and S. Smirnov for useful discussions. Research was partly supported by NSF under the grant DMS-0100593 (AO), by the Packard Foundation (AO), by PΦΦИ under the grant 01-01-00549 (NN), by the grant 00-15-96557 (NN) for the scientific schools, and by Clay Mathematical Institute (NN).

AO thanks Institut Henri Poincare for hospitality. NN thanks Institute for Advanced Study, New High Energy Theory Center at Rutgers University, Kavli Institute for Theoretical Physics at University of California Santa Barbara, Forschungsinstitut für Mathematik, ETH Zurich, University of São Paulo, and ICTP, Trieste, for hospitality during preparation of the manuscript.

**Note added:** H. Nakajima informed us that he and K. Yoshioka found another proof [21] of our main theorem of the section 4, which relates the partition function, prepotential and the Seiberg-Witten curves. They are using the blowup techniques.

## 2. $\mathcal{N} = 2$ GAUGE THEORY, DEFORMATIONS AND BACKGROUNDS

In this section we remind the construction of [9][10] and also provide quite a few new details. We consider  $\mathcal{N} = 2$  supersymmetric gauge theory with the gauge group  $U(N)$ . We study Euclidean path integral with the fixed vev of the adjoint Higgs field, on  $\mathbf{R}^4$  with certain nonminimal couplings. Most of the interesting dynamics in such theories is associated with instanton [22] effects [23].

### 2.1. Lagrangian, fields, couplings

The simplest way to write down the action of the four dimensional super-Yang-Mills theory with extended supersymmetry is to use dimensional reduction of the higher dimensional minimal supersymmetric theory.

In particular, starting with the six dimensional  $\mathcal{N} = 1$  SYM we arrive at:

$$\begin{aligned}
 L_{flat} = & \frac{1}{4g_0^2} \int \sqrt{G} d^4x \operatorname{Tr} \left\{ -F_{IJ} F^{IJ} - 2D_I \phi D^I \bar{\phi} - [\phi, \bar{\phi}]^2 \right. \\
 & \left. - i\bar{\lambda}_{\mathbf{i}}^{\dot{\alpha}} \sigma_{\alpha\dot{\alpha}}^I D_I \lambda^{\alpha\mathbf{i}} + \frac{i}{2} \left( \phi \epsilon^{\mathbf{ij}} [\bar{\lambda}_{\dot{\alpha}\mathbf{i}}, \bar{\lambda}_{\dot{\alpha}\mathbf{j}}] - \bar{\phi} \epsilon_{\mathbf{ij}} [\lambda^{\alpha\mathbf{i}}, \lambda_{\alpha}^{\mathbf{j}}] \right) \right\} + \quad (2.1) \\
 & \frac{\vartheta_0}{2\pi} \int \operatorname{Tr} F \wedge F
 \end{aligned}$$

Here,  $A_I, \phi, \bar{\phi}$  are the components of the six dimensional gauge field, which decompose as the four dimensional gauge field and an adjoint complex Higgs field (or two real Higgs fields);  $\lambda_{\alpha\mathbf{i}}$  are  $\mathcal{N} = 2$  gluions – the pair of the four dimensional Weyl spinors, transforming in the adjoint representation of the gauge group.

The indices  $\alpha, \beta = 1, 2$  correspond to the doublet of the  $SU(2)_L$ ,  $\dot{\alpha}, \dot{\beta} = 1, 2$  is that for  $SU(2)_R$ , while  $\mathbf{i}, \mathbf{j} = 1, 2$  are the internal indices, which reflect the  $SU(2)_I$  R-symmetry of the theory. They are raised and lowered using the  $SU(2)$  invariant tensor  $\varepsilon_{12} = -\varepsilon_{21} = 1 = \varepsilon^{21} = -\varepsilon^{12}$ . Space-time Lorentz indices will be denoted throughout the paper by the upper case Latin letters  $I, J, \dots = 1, 2, 3, 4$ . The Pauli tensors, relating the spinor and vector indices, are  $\sigma_{I\alpha\dot{\alpha}}$ .

In (2.1) we have put the bare coupling constant  $g_0$  and the bare theta angle  $\vartheta_0$ . The bare coupling corresponds to some high energy cut-off scale  $\mu$ .

The action (2.1) is the limit of the six dimensional action of the theory put on a six manifold  $\mathbf{T}^2 \times \mathbf{R}^4$  with the standard flat product metric.

## 2.2. $\Omega$ -background

However, in going from six to four dimensions one may have started with a nontrivial six dimensional metric. In particular, by reducing on the two torus one may have considered  $\mathbf{R}^4$  bundles with nontrivial flat  $SO(4)$  connections, such as the space  $\mathcal{N}_6$  with the metric:

$$ds^2 = Adz d\bar{z} + g_{IJ} \left( dx^I + V^I dz + \bar{V}^I d\bar{z} \right) \left( dx^J + V^J dz + \bar{V}^J d\bar{z} \right) \quad (2.2)$$

with  $V^I = \Omega_J^I x^J$ ,  $\bar{V}^I = \bar{\Omega}_J^I x^J$ , and the area  $A$  of the torus to be sent to zero. For  $[\Omega, \bar{\Omega}] = 0$  the metric (2.2) is flat.

However, for  $\Omega \neq 0$  the background (2.2) will break all supersymmetries. Indeed, the spinors  $\epsilon_\alpha^i, \bar{\epsilon}_{\dot{\alpha}i}$  generating supersymmetries of the (2.1) are the components of the six dimensional Weyl spinor. In order to generate the symmetry of the theory on a curved background the spinor must be covariantly constant. In our case this means that the spinor, viewed as four dimensional Weyl spinor, should be invariant under the holonomies around the two cycles of the two-torus, which is possible only for discrete choices of  $\Omega, \bar{\Omega}$ .

### 2.2.1. $\Omega$ -background in the physical formalism

Fortunately there exists a continuous deformation of the  $\mathcal{N} = 2$  theory preserving some fermionic symmetry (which also deforms along the way). The trick is to use the R-symmetry, which is manifest in the four dimensional theory — the  $SU(2)$  group, which acts on the internal index  $\mathbf{i} = 1, 2$  of the gluinos  $\lambda$ .

Namely, in addition to the nontrivial metric (2.2) we turn on a Wilson loop in the R-symmetry group, which should compensate some part of the metric induced holonomy on the spinors.

As a result, in the limit  $A \rightarrow 0$  with  $\Omega, \bar{\Omega}$  fixed the action (2.1) gets extra terms:

$$\Delta L = \Omega_J^I L_I^{(1) J} + \bar{\Omega}_J^I \bar{L}_I^{(1) J} + \Omega_J^I \bar{\Omega}_L^K L_{IK}^{(2) JL} \quad (2.3)$$

where

$$L_I^{(1) J} = \int d^4x \sqrt{G} \left( x^J \left( \text{Tr} F_{IK} D^K \bar{\Phi} + \epsilon^{ij} \text{Tr} \bar{\lambda}_{\dot{\alpha}i} D_I \bar{\lambda}_j^{\dot{\alpha}} \right) + G^{JK} \bar{\sigma}_{IK}^{ij} \text{Tr} [\bar{\lambda}_{\dot{\alpha}i}, \bar{\lambda}_j^{\dot{\alpha}}] \right) \quad (2.4)$$

where the tensor  $\bar{\sigma}_{IK}^{ij} = -\bar{\sigma}_{KI}^{ij} = \bar{\sigma}_{IK}^{ji} = \frac{1}{2} \epsilon_{IKJL} \bar{\sigma}^{ij JL}$  is the 't Hooft projector:  $\mathfrak{so}(4) = \mathfrak{su}_L(2) \oplus \mathfrak{su}_R(2) \rightarrow \mathfrak{su}_R(2) = \left( \left( \frac{1}{2} \right) \otimes \left( \frac{1}{2} \right) \right)_{sym}$ :

$$\sigma_{IJ\dot{\alpha}}^{\dot{\beta}} = \frac{1}{4} \left( \sigma_I^{\beta\dot{\beta}} \sigma_{J\beta\dot{\alpha}} - \sigma_J^{\beta\dot{\beta}} \sigma_{I\beta\dot{\alpha}} \right)$$



and, for future use:

$$\sigma_{IJ\alpha}^\beta = \frac{1}{4} \left( \sigma_{I\alpha\dot{\alpha}} \sigma_J^{\beta\dot{\alpha}} - \sigma_{J\alpha\dot{\alpha}} \sigma_I^{\beta\dot{\alpha}} \right)$$

Finally,

$$L_{IK}^{(2)JL} = \int d^4x \sqrt{G} x^J x^L G^{MN} \text{Tr} F_{IM} F_{KN} \quad (2.5)$$

### 2.2.2. $\Omega$ -background in the twisted formalism

Supersymmetric gauge theories with extended supersymmetry can be formulated in a way which guarantees the existence of a nilpotent symmetry in any curved background. This formulation, sometimes called twisted, or topological, or cohomological, makes use of the R-symmetry of the theory. The coupling to the curved metric is accompanied by the coupling to the R-symmetry gauge field, which is taken to be equal to the corresponding projection of the spin connection[24][25]. In this way, the fermions of the pure gauge theory become a one-form  $\psi$ , a self-dual two-form  $\chi$ , and a scalar  $\eta$ . The bosons  $A_I$  and  $\phi$  are not sensitive to the twisting.

The advantage of such a formulation of the theory is the clear geometric meaning of all the terms in the action. It is well-known, that  $\mathcal{N} = 2$  super-Yang-Mills in the twisted formulation provides an integral representation for the Donaldson invariants of four-manifolds (for  $G = SO(3)$ ). In our study the gauge theory lives on  $\mathbf{R}^4$  which is boring topologically. However, we study something different from the Donaldson theory, due to  $\Omega$ -background. It corresponds to the  $K$ -equivariant version of Donaldson invariants,  $K = Spin(4)$  being the group of rotations.

In general, if the metric  $G = G_{IJ} dx^I dx^J$  of the Euclidean space-time manifold has some isometries, one can deform the standard Donaldson-Witten [24][26] action, by coupling it to the isometry vector fields  $V$  and  $\bar{V}$ , which should commute  $[V, \bar{V}] = 0$ . Explicitly, the action of the theory is given by:

$$\begin{aligned} L = & \frac{1}{2g_0^2} \left( -\frac{1}{2} \text{Tr} F \star F + \text{Tr} (D_A \phi - \iota_V F) \star (D_A \bar{\phi} - \iota_{\bar{V}} F) + \frac{1}{2} \text{Tr} [\phi, \bar{\phi}]^2 \text{vol}_g \right) \\ & + \text{Tr} \left( \chi (D_A \psi)^+ + \eta D_A^* \psi + \chi \star L_V \chi + \eta \wedge \star L_V \eta + \psi \star L_{\bar{V}} \psi \right) \\ & + \text{Tr} \left( \chi \star [\phi, \chi] + \eta \star [\phi, \eta] + \psi \star [\bar{\phi}, \psi] \right) \\ & + \frac{\vartheta_0}{2\pi} \text{Tr} F \wedge F \end{aligned} \quad (2.6)$$

On  $\mathbf{R}^4$ , we take, as above,

$$V^I = \Omega^I_J x^J, \quad \bar{V}^I = \bar{\Omega}^I_J x^J \quad (2.7)$$

with

$$\Omega^{IJ} = \begin{pmatrix} 0 & \epsilon_1 & 0 & 0 \\ -\epsilon_1 & 0 & 0 & 0 \\ 0 & 0 & 0 & \epsilon_2 \\ 0 & 0 & -\epsilon_2 & 0 \end{pmatrix}, \quad \bar{\Omega}^{IJ} = \begin{pmatrix} 0 & \bar{\epsilon}_1 & 0 & 0 \\ -\bar{\epsilon}_1 & 0 & 0 & 0 \\ 0 & 0 & 0 & \bar{\epsilon}_2 \\ 0 & 0 & -\bar{\epsilon}_2 & 0 \end{pmatrix} \quad (2.8)$$

where  $\Omega^{IJ} = G^{JK}\Omega^I_K$  etc.

### 2.3. On supersymmetry

For completeness, we list here the formulae for the supersymmetries of the actions (2.1)(2.3)(2.6).

#### 2.3.1. Supersymmetry of the physical theory

The supercharges transform in the representation  $(\mathbf{2}, \mathbf{1}, \mathbf{2}) \oplus (\mathbf{1}, \mathbf{2}, \mathbf{2})$  of the Lorentz  $\times$  R-symmetry group  $SU(2)_L \times SU(2)_R \times SU(2)_I$ . Introducing the corresponding infinitesimal parameters:  $\zeta_\alpha^{\mathbf{i}}$  and  $\bar{\zeta}_{\dot{\alpha}}^{\mathbf{i}}$  the supersymmetry transformations can be written

$$\begin{aligned} \delta A_I &= -i\bar{\lambda}_{\mathbf{i}}^{\dot{\alpha}} \sigma_{I\alpha\dot{\alpha}} \zeta^{\alpha\mathbf{i}} - i\lambda^{\alpha\mathbf{i}} \sigma_{I\alpha\dot{\alpha}} \bar{\zeta}_{\dot{\alpha}}^{\mathbf{i}} \\ \delta \lambda_{\alpha\mathbf{i}} &= \sigma_{\alpha\beta}^{IJ} \zeta^{\beta\mathbf{i}} F_{IJ} + i\zeta_{\alpha}^{\mathbf{i}} D + i\sqrt{2}\sigma_{\alpha\dot{\alpha}}^I D_I B \epsilon^{ij} \bar{\zeta}_{\mathbf{j}}^{\dot{\alpha}} \\ \delta \bar{\lambda}_{\dot{\alpha}}^{\mathbf{i}} &= \sigma_{\dot{\alpha}\dot{\beta}}^{IJ} \bar{\zeta}_{\mathbf{i}}^{\dot{\beta}} F_{IJ} - i\bar{\zeta}_{\dot{\alpha}\mathbf{i}} D + i\sqrt{2}\sigma_{\alpha\dot{\alpha}}^I D_I \bar{B} \epsilon_{ij} \zeta^{\alpha\mathbf{j}} \\ \delta B &= \sqrt{2}\zeta^{\alpha\mathbf{i}} \lambda_{\alpha\mathbf{i}} \\ \delta \bar{B} &= \sqrt{2}\bar{\zeta}_{\dot{\alpha}}^{\mathbf{i}} \bar{\lambda}_{\dot{\alpha}}^{\mathbf{i}} \end{aligned} \quad (2.9)$$

with the auxiliary field  $D = [B, \bar{B}]$ .

#### 2.3.2. Twisted superalgebra

The twisted formulation of the theory is achieved by replacing the Lorentz group  $K = SU(2)_L \times SU(2)_R \in K \times SU(2)_I$  by another subgroup of  $K \times SU(2)_I$ , namely  $SU(2)_L \times SU(2)_d$ , with  $SU(2)_d$  being diagonally embedded into  $SU(2)_R \times SU(2)_I$ . In other words, the internal index  $\mathbf{i}$  is identified with another  $SU(2)_R$  index,  $\dot{\alpha}$ . The fields are redefined, according to

$$\psi_I = \lambda_{\alpha\dot{\beta}} \sigma_I^{\alpha\dot{\beta}}, \quad \chi_{IJ} = \sigma_{IJ\dot{\alpha}\dot{\beta}} \bar{\lambda}^{\dot{\alpha}\dot{\beta}}, \quad \eta = \epsilon_{\dot{\alpha}\dot{\beta}} \bar{\lambda}^{\dot{\alpha}\dot{\beta}} \quad (2.10)$$

Similarly, the supersymmetry parameters  $\zeta_\alpha^{\mathbf{i}}$  become  $\zeta^I$ ,  $\bar{\zeta}_{\dot{\alpha}\mathbf{i}}$  become  $\zeta^{IJ}$  and  $\zeta$ . Of course,  $\zeta^{IJ}$  is self-dual.

The supersymmetry algebra becomes:

$$\begin{aligned}
\delta A_I &= -i\zeta\psi_I - i\zeta_{IJ}\psi^J - i\zeta_I\eta \\
\delta\psi_I &= +\zeta^J F_{IJ}^- + i\zeta_I D + i\zeta D_I\phi \\
\delta\chi_{IJ} &= \zeta F_{IJ}^+ - i\zeta_{IJ}D + i(\zeta_{[I}D_{J]}\bar{\phi})^+ \\
\delta\eta &= \zeta^{IJ}F_{IJ} - i\zeta D + \zeta^I D_I\bar{\phi} \\
\delta\phi &= \zeta^I\psi_I \\
\delta\bar{\phi} &= \zeta\eta + \zeta^{IJ}\chi_{IJ} .
\end{aligned} \tag{2.11}$$

The geometric meaning of the transformations  $\delta$  is the following. The space of the fields  $A_I, \phi, \psi_I$ , represents the  $\mathcal{G}$ -equivariant de Rham complex of the space  $\mathcal{A}$  of gauge fields on  $\mathbf{R}^4$ , together with the ingredients needed to construct a Mathai-Quillen representative of the Euler class of a certain infinite dimensional bundle over  $\mathcal{A}$ , and the projection form[27] associated with the projection  $\mathcal{A} \rightarrow \mathcal{A}/\mathcal{G}$ .

The space  $\mathbf{R}^4$  is hyperkähler, and possesses an action of the group  $\mathbf{R}^4$  of translations.

The transformation generated by  $\zeta$  is the  $\mathcal{G}$ -equivariant de Rham differential. The transformations, generated by  $\zeta^{IJ}$  correspond to the  $\mathcal{G}$ -equivariant  $\bar{\partial}_{\mathcal{I},\mathcal{J},\mathcal{K}}$  differentials, corresponding to the three complex structures on  $\mathcal{A}$  induced from the complex structures on  $\mathbf{R}^4$ . Finally,  $\zeta^I$  correspond to the operators  $\iota_{\partial_I}$  of contraction with the vector fields on  $\mathcal{A}$ , induced by the vector fields

$$\frac{\partial}{\partial x^I}$$

generating translations of  $\mathbf{R}^4$ .

### 2.3.3. Supersymmetry of the $\Omega$ -background

The transformations, which generate the symmetry of the  $\Omega$ -background utilize the rotational symmetries of  $\mathbf{R}^4$ . To the vector field

$$V = \Omega^I_J x^J \frac{\partial}{\partial x^I}$$

there is an associated vector field on  $\mathcal{A}$  and the associated operation of contraction on the  $\mathcal{G}$ -equivariant de Rham complex. In terms of the transformations  $\delta$  of twisted theory these

are simply the transformation (2.11) with the space-dependent transformation parameter  $\zeta^I = V^I(x) = \Omega_J^I x^J$ .

The theory (2.3) is invariant under the transformation, generated by:

$$(\zeta, \zeta^I, \zeta^{IJ}) = (\zeta, V^I(x)\zeta, 0)$$

The supercharge, generating this transformation, will be denoted as  $\tilde{Q}$ .

## 2.4. Noncommutative deformation

The theory (2.1) allows yet another deformation, which we shall implicitly use to simplify our calculations. Let  $\Theta^{IJ} = -\Theta^{JI}$  be a constant Poisson tensor on  $\mathbf{R}^4$ . The theory on  $\mathbf{R}^4$  can be deformed to that on the noncommutative space,  $\mathbf{R}_\Theta^4$ . A naive way to define this deformation is to replace all the products of functions (or components of various tensor fields) in (2.1) by the so-called Moyal product:

$$f \star g(x) = \exp \frac{i}{2} \Theta^{IJ} \frac{\partial}{\partial \xi^I} \frac{\partial}{\partial \eta^J} \Big|_{\eta=\xi=0} f(x+\xi)g(x+\eta) \quad (2.12)$$

More conceptual definition goes as follows (cf. [28][29]). Consider the theory (2.1) dimensionally reduced to zero space-time dimensions. We get some sort of supersymmetric matrix model. Replace the matrices by the operators in the Hilbert space  $\mathcal{H}$ . Explicitly, we get the theory of six bosonic operators

$$X^I, \quad \Phi, \bar{\Phi}; \quad I = 1, \dots, 4 \quad (2.13)$$

and eight fermionic ones (we use twisted formulation):

$$\Psi^I, \quad \eta, \quad \chi^{IJ} = \frac{1}{2} \varepsilon^{IJKL} \chi_{KL}; \quad I, J = 1, \dots, 4 \quad (2.14)$$

where we lower indices using some Euclidean metric  $g_{IJ}$ :

$$\chi_{KL} = g_{KI} g_{LJ} \chi^{IJ},$$

The action reads:

$$\begin{aligned} L = & -\frac{1}{4\mathbf{g}^2} \text{Tr}_{\mathcal{H}} \left( g_{IK} g_{JL} ([X^I, X^J][X^K, X^L] + \chi^{IJ}[X^K, \Psi^L] + \chi^{IJ}[\Phi, \chi^{KL}]) \right. \\ & + 2g_{IJ} (\eta[X^I, \Psi^J] + [\bar{\Phi}, X^I][\Phi, X^J] + \Psi^I[\bar{\Phi}, \Psi^J]) \\ & \left. + ([\Phi, \bar{\Phi}]^2 + \eta[\Phi, \eta]) \right) \\ & + \text{Tr}_{\mathcal{H}} \left( iB_{IJ}[X^I, X^J] + \frac{\vartheta}{8\pi} \varepsilon_{IJKL}[X^I, X^J][X^K, X^L] + L_0 \right) \end{aligned} \quad (2.15)$$

The action (2.15) leads to the equations of motion which do not depend on the parameters entering the last line in (2.15), i.e.  $B_{IJ}, \vartheta_0, L_0$ .

•

A special class of extrema of the action (2.15) with all the fermionic fields set to zero is achieved on the operators  $X^I, \Phi, \bar{\Phi}$  obeying:

$$\begin{aligned} [X^I, X^J] &= i\Theta^{IJ} \mathbf{1}, & \Theta^{IJ} &= 2g_0^2 g^{IK} g^{JL} B_{KL} \\ [X^I, \Phi] &= 0 = [X^I, \bar{\Phi}] & &= [\Phi, \bar{\Phi}] \end{aligned} \quad (2.16)$$

Let us fix a standard set of operators  $\mathbf{x}^I$  in  $\mathcal{H}$  obeying

$$[\mathbf{x}^I, \mathbf{x}^J] = i\Theta^{IJ} \mathbf{1} \quad (2.17)$$

The algebra (2.17) may be represented reducibly in  $\mathcal{H}$ . In general, for nondegenerate  $\Theta^{IJ}$ ,

$$\mathcal{H} = \mathcal{H}_0 \otimes W \quad (2.18)$$

where  $\mathcal{H}_0$  is irreducible representation of (2.17), and  $W$  is a multiplicity space, which we shall assume to be a finite dimensional Hermitian vector space, of complex dimension  $N$ . From now on,  $\mathbf{x}^I$  will denote the operators on  $\mathcal{H}_0$ . The corresponding operators on  $\mathcal{H}$  will be denoted as  $\mathbf{x}^I \otimes \mathbf{1}_N$ . Expanding:

$$X^I = \mathbf{x}^I \otimes \mathbf{1}_N + i\Theta^{IJ} A_J(\mathbf{x}), \quad \Phi = \phi(\mathbf{x}) = \mathbf{1} \otimes \mathbf{a} + \phi_\infty(\mathbf{x}), \quad \Psi^I = \Theta^{IJ} \psi_J(\mathbf{x}) \quad (2.19)$$

where  $\phi_\infty(x) \rightarrow 0, x \rightarrow \infty$ , we arrive at the naive formulation, with the metric on  $\mathbf{R}^4$ , given by:

$$\begin{aligned} G^{IJ} &= g_{KL} \Theta^{IK} \Theta^{JL} \\ \vartheta_0 &= \vartheta \text{ Pf}(\Theta) \\ \frac{1}{g_0^2} &= \frac{1}{\mathbf{g}^2} \text{ Pf}(\Theta) \sqrt{\det g} \end{aligned} \quad (2.20)$$

In (2.19), both  $A_J = A_{J|ln} \otimes E^{ln}$  and  $\phi$  are valued in the  $N \times N$  matrices, anti-Hermitian operators in  $W$ . To arrive at the ordinary gauge theory, we should take the limit  $\Theta \rightarrow 0$ , while keeping  $G_{IJ}, g_0^2, \vartheta_0$  finite. The curvature  $F$  of the gauge field  $A$  is given by:

$$[X^I, X^J] = i\Theta^{IJ} + \Theta^{IK} \Theta^{JL} F_{KL} \quad (2.21)$$

### 2.4.1. Combining $\Omega$ and $\Theta$

The universal gauge theory (2.15) can also be subject to the nontrivial  $\Omega$ -background:

$$\begin{aligned}
L = & -\frac{1}{4\mathbf{g}^2} \text{Tr}_{\mathcal{H}} \left( g_{IK}g_{JL} \left( [X^I, X^J][X^K, X^L] + \right. \right. \\
& \left. \left. + \chi^{IJ}[X^K, \Psi^L] + \chi^{IJ}([\Phi, \chi^{KL}] + 2\Omega_M^K \chi^{ML}) \right) \right. \\
& \left. + 2g_{IJ} \left( \left( [\bar{\Phi}, X^I] + \bar{\Omega}_L^I X^L \right) \left( [\Phi, X^J] + \Omega_K^J X^K \right) + \right. \right. \\
& \left. \left. + \eta[X^I, \Psi^J] + \Psi^I([\bar{\Phi}, \Psi^J] + \bar{\Omega}_L^J \Psi^L) \right) \right. \\
& \left. + ([\Phi, \bar{\Phi}]^2 + \eta[\Phi, \eta]) \right) \\
& + \text{Tr}_{\mathcal{H}} \left( iB_{IJ}[X^I, X^J] + \frac{\vartheta}{8\pi} \varepsilon_{IJKL}[X^I, X^J][X^K, X^L] + L_0 \right)
\end{aligned} \tag{2.22}$$

The vacua of the theory (2.22) are given by the operators which solve slightly different equations than (2.16). Namely, the condition on  $\Phi$  is now:

$$[X^I, \Phi] = \Omega_J^I X^J, \quad [X^I, \bar{\Phi}] = \bar{\Omega}_J^I X^J \tag{2.23}$$

which is consistent with  $[X^I, X^J] = i\Theta^{IJ}$  only under certain conditions on  $\Omega, \Theta, \bar{\Omega}$ . Namely, assuming nondegeneracy of  $\Theta$ , with  $\omega = \Theta^{-1}$ , the matrices

$$\mathcal{E}_{IJ} = \Omega_J^K \omega_{KI}, \quad \bar{\mathcal{E}}_{IJ} = \bar{\Omega}_J^K \omega_{KI}, \tag{2.24}$$

must be symmetric. Then the solution to (2.16) is given by:

$$X^I = \mathbf{x}^I, \quad \Phi = \frac{1}{2}\mathcal{E}_{IJ}\mathbf{x}^I\mathbf{x}^J, \quad \bar{\Phi} = \frac{1}{2}\bar{\mathcal{E}}_{IJ}\mathbf{x}^I\mathbf{x}^J \tag{2.25}$$

Now, the gauge field  $A_I$  and the Higgs field  $\phi$  are introduced via:

$$X^I = \mathbf{x}^I \otimes \mathbf{1}_N + i\Theta^{IJ}A_J(\mathbf{x}), \quad \Phi = \frac{1}{2}\mathcal{E}_{IJ}X^IX^J \otimes \mathbf{1}_N + \phi(\mathbf{x}) \tag{2.26}$$

### 2.4.2. Supersymmetry of the noncommutative theory in $\Omega$ background

We shall only write down the supercharge of our interest:

$$\begin{aligned}
\tilde{Q}X^I &= \Psi^I, \quad \tilde{Q}\Psi^I = [\Phi, X^I] + \Omega_J^I X^J \\
\tilde{Q}\Phi &= 0, \quad \tilde{Q}\chi^{IJ} = H^{IJ} \\
\tilde{Q}H^{IJ} &= [\Phi, \chi^{IJ}] - (\Omega_K^I \chi^{JK} - \Omega_K^J \chi^{IK})^+ \\
\tilde{Q}\bar{\Phi} &= \eta, \quad \tilde{Q}\eta = [\Phi, \bar{\Phi}]
\end{aligned} \tag{2.27}$$

Here  $H^{IJ}$  is an auxiliary field, which is equal to  $[X^I, X^J]^+$  on-shell.

### 2.4.3. Observables in the supersymmetric gauge theory: $\Omega = 0$

In the ordinary  $\mathcal{N} = 2$  supersymmetric gauge theory a special class of observables play an important role. They are distinguished by the property, that a certain supercharge annihilates them. Of particular interest for application to Donaldson theory are the observables which are constructed out of the invariant polynomials in the Higgs field  $\phi$  by means of the descend procedure. In terms of the twisted fields, these observables look as follows. Let  $P(\phi)$  be any  $G$ -invariant polynomial on the Lie algebra  $\mathfrak{g} = Lie(G)$  of the gauge group  $G$ . Then:

$$\begin{aligned}
\mathcal{O}_P^{(0)}(x) &= P(\phi(x)) \\
\mathcal{O}_P^{(1)}(C) &= \oint_C \frac{\partial P}{\partial \phi^a} \psi^a \\
\mathcal{O}_P^{(2)}(\Sigma) &= \int_\Sigma \frac{\partial P}{\partial \phi^a} F^a + \frac{1}{2} \frac{\partial^2 P}{\partial \phi^a \partial \phi^b} \psi^a \wedge \psi^b \\
&\vdots \\
\mathcal{O}_P^{(4)}(X) &= \int_X \frac{1}{2} \frac{\partial^2 P}{\partial \phi^a \partial \phi^b} F^a \wedge F^b + \dots + \frac{1}{24} \frac{\partial^4 P}{\partial \phi^a \partial \phi^b \partial \phi^c \partial \phi^d} \psi^a \wedge \psi^b \wedge \psi^c \wedge \psi^d
\end{aligned} \tag{2.28}$$

Here,  $x, C, \Sigma, \dots, X$  represent a 0, 1, 2, ..., 4-cycles in the space-time manifold, respectively. The main idea behind (2.28) is to use the fact that the supercharge  $Q$  acts on  $P(\Phi(x) + \dots)$  as the de Rham differential. To compare the observables of the ordinary gauge theory to those of the noncommutative gauge theory we shall utilize the generating function(form):

$$\mathcal{O}_P = P(\phi(x) + \psi_I(x) dx^I + \frac{1}{2} F_{IJ}(x) dx^I \wedge dx^J) \in \Omega^*(\text{spacetime}) \tag{2.29}$$

Its main property is:

$$d_x \langle \mathcal{O}_P(x) \dots \rangle = 0$$

•

The noncommutative gauge symmetry does not allow, naively, for the local observables like in the first line of (2.28). However, it has as many gauge invariant observables as does the ordinary theory. For the gauge group  $U(N)$  the invariant polynomials can be expressed as polynomials in the single trace operators

$$P_n(\phi) = \text{Tr}\phi^n \quad (2.30)$$

It is convenient to introduce the character:

$$P_\beta(\phi) = \text{Tr}e^{i\beta\phi} = \sum_{n=0}^{\infty} \frac{(i\beta)^n}{n!} P_n \quad (2.31)$$

The analogue of (2.28)(2.29) is the following closed form on  $\mathbf{R}^4$ :

$$\mathcal{O}_{P_\beta}(x, dx) = \beta^2 e^{-\beta\omega} \int d^4\vartheta d^4\kappa e^{-i\beta(\kappa_I x^I + \vartheta_I dx^I)} \text{Tr}_{\mathcal{H}} e^{i\beta\Phi(\vartheta, \kappa)} \quad (2.32)$$

where

$$\Phi(\vartheta, \kappa) = \Phi + \kappa_I X^I + \vartheta_I \Psi^I + \frac{1}{2} \vartheta_I \vartheta_J [X^I, X^J], \quad \omega = \frac{1}{2} \omega_{IJ} dx^I \wedge dx^J \quad (2.33)$$

The closedness of  $\mathcal{O}_{P_\beta}$  is proved with the help of the symmetry acting on  $\vartheta, \kappa$ :

$$\delta\vartheta = \kappa, \quad \delta\kappa = 0 \quad (2.34)$$

#### 2.4.4. Observables: $\Omega \neq 0$

The chiral observables get deformed when  $\Omega \neq 0$ . First of all, in the ordinary gauge theory, the generating form  $\mathcal{O}_P$  becomes equivariantly closed under correlator:

$$(d + \iota_V) \mathcal{O}_P = 0 \quad (2.35)$$

In the noncommutative gauge theory we get the same statement, but now we need to modify the symmetry  $\delta$  to its equivariant analogue:

$$\delta\vartheta_I = \kappa_I, \quad \delta\kappa_I = -\Omega_I^J \vartheta_J \quad (2.36)$$



and change (2.32) to:

$$\mathcal{O}_{P_\beta; \Omega} = \prod_{\alpha=1,2} \frac{e^{\beta\epsilon_\alpha} - 1}{\epsilon_\alpha} e^{\beta\omega_\Omega} \int d^4\vartheta d^4\kappa e^{-i\beta(\kappa_I x^I + \vartheta_I dx^I)} \text{Tr}_{\mathcal{H}} e^{i\beta\Phi(\vartheta, \kappa)} \quad (2.37)$$

$$\omega_\Omega = \frac{1}{2} (\omega_{IJ} dx^I \wedge dx^J - \mathcal{E}_{IJ} x^I x^J)$$

In what follows we consider either 0-observable, or integrated 4-observable. In the first case, we set  $x = 0$  (to be at the fixed point), and get the integral over the  $\vartheta, \kappa$  of  $\text{Tr}_{\mathcal{H}} e^{i\beta\Phi(\vartheta, \kappa)}$ . In the second case, we get the integral over the  $\vartheta, \kappa$  of  $\text{Tr}_{\mathcal{H}} e^{i\beta\Phi(\vartheta, \kappa)}$  with an extra  $\delta$ -invariant Gaussian factor. Actually, (2.36) implies that the integral over  $\vartheta, \kappa$  is localized at  $\kappa = \vartheta = 0$ , so that both 0- and 4-observables are equal, up to a  $\epsilon_\alpha$ -dependent factor:

$$\begin{aligned} \mathcal{O}_{P_\beta; \Omega}^{(0)} &= \prod_{\alpha=1,2} (e^{\beta\epsilon_\alpha} - 1) \text{Tr}_{\mathcal{H}} e^{i\beta\Phi} \\ \int_{\mathbf{R}^4} \mathcal{O}_{P_\beta; \Omega}^{(4)} &= \prod_{\alpha=1,2} \frac{e^{\beta\epsilon_\alpha} - 1}{\epsilon_\alpha} \text{Tr}_{\mathcal{H}} e^{i\beta\Phi} \end{aligned} \quad (2.38)$$

The observables (2.38) are most natural in the five dimensional gauge theory compactified on the circle of the circumference  $\beta$ . The periodicity of  $\mathcal{O}_{P_\beta}$  in  $\Phi$  has there a simple origin – large gauge transformations [14]. We shall return to this theory in the section 7.

### 3. GAUGE THEORY PARTITION FUNCTION

In the ordinary gauge theory the natural object of study is the Euclidean path integral over the field configurations, such that

$$\phi(x) \rightarrow \mathbf{a}, \quad x \rightarrow \infty \quad (3.1)$$

We are aiming to calculate the path integral in the  $\Omega$ -background, with the boundary conditions (3.1) (and, in fact, using noncommutative deformation):

$$Z(\mathbf{a}, \epsilon_1, \epsilon_2; \Lambda) = \int DAD\psi D\eta D\chi D\Phi D\bar{\Phi} e^{-\int_{\mathbf{R}^4} L \sqrt{g} d^4x} \quad (3.2)$$

In the noncommutative gauge theory the condition (3.1) is phrased differently. Think of  $\Phi$  as of the element of the Lie algebra of the group  $\mathcal{G}_\Theta \approx U(\mathcal{H})$  of gauge transformations (note that normally one takes  $\mathcal{G}_\Theta = PU(\mathcal{H})$ ). The identification  $\mathcal{H} = \mathbf{C}^N \otimes \mathcal{H}_0$  allows to view  $\Phi$  as an  $N \times N$  matrix of operators in  $\mathcal{H}_0$ . The condition (3.1) is now stated as follows:

$$\Phi = \mathbf{a} \otimes \mathbf{1}_{\mathcal{H}_0} + \frac{1}{2} \mathbf{1}_N \otimes \mathcal{E}_{IJ} \mathbf{x}^I \mathbf{x}^J + \varphi(\mathbf{x}) \quad (3.3)$$

where  $\varphi(x) \rightarrow 0$  as  $x \rightarrow \infty$ , faster than any power of  $x$ .

•

The integral (3.2) needs an UV cutoff  $\mu$ . The bare couplings  $g_0$  and  $\vartheta_0$  are renormalized, thus generating an effective scale  $\Lambda$ ,

$$\Lambda^{2N} \sim \mu^{2N} e^{-\frac{8\pi^2}{g_0^2} + 2\pi i \vartheta_0} \quad (3.4)$$

**Remark:** On  $U(1)$  factor. The gauge theory with the gauge group  $U(N)$  has an interesting pattern of the renormalization group flow. The ordinary gauge theory has a decoupled  $U(1)$  factor, which does not exhibit any renormalization of its coupling, and interacting  $SU(N)$  part, with the famous phenomenon of asymptotic freedom, reflected in (3.4). When the theory is deformed by  $\Theta$ , the perturbative loop calculations are altered, in a  $\Theta$ -dependent way, as it introduces, among other things, an energy scale. In particular, the  $U(1)$  factor coupling constant starts running, in the energy range

$$\mu \gg \Lambda \gg \frac{1}{\mu\Theta}$$

where the formula (3.4) with  $N = 1$  holds (this result is a simple generalization of [30], which can also be justified using [1][31]). The  $U(1)^{N-1} \subset SU(N)$  gauge couplings experience different renormalization group flow, as they are affected by the loops of the charged  $W$ -bosons. In principle, we should introduce two distinct low-energy scales, one for  $SU(N)$  part of the gauge group, another for  $U(1)$ :  $\Lambda, \Lambda_0$ . As we shall eventually remove noncommutativity, it makes sense to keep  $\Lambda_0 \approx \mu$ . We shall encounter the ambiguity related to the  $U(1)$  factor in the analysis of the Seiberg-Witten curves. In the paper we concentrate on the  $SU(N)$  dynamics, and mostly set  $a = 0$ .

**Remark:** The theory (2.1) has an anomalous  $U(1)_{gh}$  symmetry ( $gh$  for ghost). Under this symmetry, the adjoint Higgs field  $\Phi$  has charge  $+2$ ,  $\bar{\Phi}$  has charge  $-2$ , the fermions  $\psi$  have charge  $+1$ ,  $\chi, \eta$  have charge  $-1$ . In the background of the instanton of charge  $k$  the path integral measure transforms under the ghost  $U(1)$  with the charge  $-4kN$ . The  $\Omega$  deformation breaks  $U(1)_{gh}$ . It can be restored by assigning  $\Omega, \bar{\Omega}$  the charges  $+2, -2$ , respectively.

### 3.1. Partition function as a sum over partitions

The partition function  $Z(\mathbf{a}, \epsilon_1, \epsilon_2; \Lambda)$  can be explicitly evaluated as a sum over instantons. Moreover, the  $\Omega$ -background lifts instanton moduli, leaving only a finite number of isolated points on the appropriately compactified instanton moduli space as a full set of supersymmetric minima of the action. The evaluation of (3.2) is then reduced to the calculation of the ratios of the bosonic and fermionic determinants near each critical point. These points are labeled by the colored partitions.

Consequently, (3.2) is given by the sum over  $N$ -tuples of partitions [9][10](see appendix **B** for the notations and definitions related to partitions). Explicitly:

$$Z(\mathbf{a}; \epsilon_1, \epsilon_2, \Lambda) = Z^{pert}(\mathbf{a}; \Lambda, \epsilon_1, \epsilon_2) \sum_{\vec{\mathbf{k}}} \Lambda^{2N|\vec{\mathbf{k}}|} Z_{\vec{\mathbf{k}}}(\mathbf{a}; \epsilon_1, \epsilon_2) \quad (3.5)$$

where:

$$\begin{aligned}
Z_{\vec{\mathbf{k}}}(\mathbf{a}; \epsilon_1, \epsilon_2) &= \prod_{l,n;i,j} \frac{a_l - a_n + \epsilon_1(i-1) + \epsilon_2(-j)}{a_l - a_n + \epsilon_1(i - \tilde{k}_{nj} - 1) + \epsilon_2(k_{li} - j)} \\
&= \prod_{l,n;i,j} \frac{a_l - a_n + \epsilon_1(-i) + \epsilon_2(j-1)}{a_l - a_n + \epsilon_1(\tilde{k}_{lj} - i) + \epsilon_2(j - k_{ni} - 1)} \\
&= \frac{1}{\epsilon_2^{2N|\vec{\mathbf{k}}|}} \prod_{(l,i) \neq (n,j)} \frac{\Gamma(k_{li} - k_{nj} + \nu(j-i+1) + b_{ln}) \Gamma(\nu(j-i) + b_{ln})}{\Gamma(k_{li} - k_{nj} + \nu(j-i) + b_{ln}) \Gamma(\nu(j-i+1) + b_{ln})},
\end{aligned} \tag{3.6}$$

$$b_{ln} = \frac{a_l - a_n}{\epsilon_2}, \quad \nu = -\frac{\epsilon_1}{\epsilon_2} \tag{3.7}$$

and

$$Z^{pert}(\mathbf{a}; \epsilon_1, \epsilon_2, \Lambda) = \exp\left(\sum_{l,n} \gamma_{\epsilon_1, \epsilon_2}(a_l - a_n; \Lambda)\right) \tag{3.8}$$

where the function  $\gamma_{\epsilon_1, \epsilon_2}$  is defined in the appendix **A**

**Remark:** The product over  $i, j$  in (3.6) in  $Z_{\vec{\mathbf{k}}}$  is infinite and needs precise definition. Here it is: Fix a pair  $(l, n)$ . Consider all the factors in  $Z_{\vec{\mathbf{k}}}$  corresponding to  $l, n$ . Split the set of indices  $(i, j)$  into four groups:

$$\begin{aligned}
\mathbf{Z}_+^2 &= S_{++} \cup S_{+-} \cup S_{-+} \cup S_{--} \\
S_{++} &= \{(i, j) \mid 1 \leq i \leq \ell(\mathbf{k}_l), 1 \leq j \leq k_{n1}\} \\
S_{+-} &= \{(i, j) \mid 1 \leq i \leq \ell(\mathbf{k}_l), k_{n1} < j\} \\
S_{-+} &= \{(i, j) \mid \ell(\mathbf{k}_l) < i, 1 \leq j \leq k_{n1}\} \\
S_{--} &= \{(i, j) \mid \ell(\mathbf{k}_l) < i, k_{n1} < j\}
\end{aligned} \tag{3.9}$$

The set  $S_{++}$  is finite, the set  $S_{--}$  contributes 1. The set  $S_{+-}$  contributes:

$$\begin{aligned}
Z_{+-; \vec{\mathbf{k}}}^{ln} &= \prod_{i=1}^{\ell(\mathbf{k}_l)} \prod_{j=k_{n1}+1}^{\infty} \frac{a_{ln} + \epsilon_1(i-1) + \epsilon_2(-j)}{a_{ln} + \epsilon_1(i-1) + \epsilon_2(k_{li} - j)} := \\
&\prod_{i=1}^{\ell(\mathbf{k}_l)} \prod_{j=1}^{k_{li}} \frac{1}{a_{ln} + \epsilon_1(i-1) + \epsilon_2(k_{li} - k_{n1} - j)}
\end{aligned} \tag{3.10}$$

and similarly for  $S_{-+}$ . See also [32].

•

The special case  $\epsilon_2 = -\epsilon_1 = \hbar$ , i.e.  $\nu = 1$  deserves a special attention. In this case, the expression for the partition function simplifies to:

$$\begin{aligned}
Z(\mathbf{a}; \hbar, \Lambda) &= \sum_{\bar{\mathbf{k}}} \Lambda^{2N|\bar{\mathbf{k}}|} Z_{\bar{\mathbf{k}}}(\mathbf{a}; \hbar) \\
Z_{\bar{\mathbf{k}}}(\mathbf{a}; \hbar) &= Z^{pert}(\mathbf{a}; \hbar) \mu_{\bar{\mathbf{k}}}^2(\mathbf{a}, \hbar) \\
\mu_{\bar{\mathbf{k}}}^2(\mathbf{a}, \hbar) &= \prod_{(l,i) \neq (n,j)} \left( \frac{a_l - a_n + \hbar(k_{l,i} - k_{n,j} + j - i)}{a_l - a_n + \hbar(j - i)} \right) \\
Z^{pert}(\mathbf{a}; \hbar) &= \exp \left( \sum_{l,n} \gamma_{\hbar}(a_l - a_n; \Lambda) \right)
\end{aligned} \tag{3.11}$$

where the function  $\gamma_{\hbar}(x; \Lambda)$  is defined in the appendix **A**.

### 3.2. Plancherel measure on partitions

In the case when  $N = 1$  and  $\nu = 1$ , the sum in (3.5) is over a single partition  $\mathbf{k}$  and the weight  $\mu_{\bar{\mathbf{k}}}(\mathbf{a}, \hbar)$  reduces to

$$\mu(\mathbf{k}) = \prod_{i < j} \left( \frac{k_i - k_j + j - i}{j - i} \right) = \prod_{\square \in \mathbf{k}} \frac{1}{h(\square)}, \tag{3.12}$$

where second the product is over all squares  $\square$  in the diagram of the partition  $\mathbf{k}$  and  $h(\square)$  denotes the corresponding hook-length.

The weight  $\mu(\mathbf{k})^2$  is known as the Plancherel measure on partitions because of the relation

$$\mu(\mathbf{k}) = \frac{\dim R_{\mathbf{k}}}{|\mathbf{k}|!}, \tag{3.13}$$

where  $R_{\mathbf{k}}$  is the irreducible representation of the symmetric group corresponding to the partition  $\mathbf{k}$ . Just like in the classical Plancherel theorem, the Fourier transform on the symmetric group an isometry of the  $L^2$ -spaces with respect to the Haar (i.e. counting) measure on the group and Plancherel measure on the set of its irreducible representations. Observe that from (3.13) it follows that

$$\sum_{|\mathbf{k}|=n} \mu^2(\mathbf{k}) = \frac{1}{n!} \tag{3.14}$$

The Plancherel measure is the most fundamental and natural measure on the set of partitions. In many aspects, the set of partitions equipped with the Plancherel measure is the proper discretization of the Gaussian Unitary Ensemble (GUE) of random matrices [33]. In particular, the integrable structures of random matrices are preserved and, in fact, become more natural and transparent for the Plancherel measure, see [34][35]. Similarly, Plancherel random partitions play a central role in the Gromov-Witten theory of target curves, extending the role played by random matrices in the case of the point target, see [36].

A pedestrian explanation of the relation between Plancherel measure and GUE can be obtained by rewriting the weight (3.12) as the product of the Vandermonde determinant in the variables  $k_i - i$  and a multinomial coefficients, which, of course, is the discrete analog of the Gaussian weight.

As we will see below in Section 5, for  $N > 1$  and  $\nu = 1$  the partition function is again related to the Plancherel measure, but now periodically weighted with period  $N$ . Finally, the case  $\nu \neq 1$  leads to the Jack polynomial analog of the Plancherel measure, see [37].

## 4. PREPOTENTIAL

In this section we study the limit  $\epsilon_1, \epsilon_2 \rightarrow 0$  of the partition function (3.2). In this limit, according to the field theory arguments [9] the partition function must behave as:

$$Z(\mathbf{a}; \epsilon_1, \epsilon_2, \Lambda) = \exp\left(-\frac{1}{\epsilon_1 \epsilon_2} \mathcal{F}(\mathbf{a}; \epsilon_1, \epsilon_2, \Lambda)\right) \quad (4.1)$$

where  $\mathcal{F}$  is analytic in  $\epsilon_1, \epsilon_2$  for  $\epsilon_{1,2} \rightarrow 0$ . We prove the conjecture of [9], which identifies  $\mathcal{F}_0(\mathbf{a}, \Lambda) \equiv \mathcal{F}(\mathbf{a}; 0, 0, \Lambda)$  with the Seiberg-Witten prepotential of the low-energy effective theory.

### 4.1. Quasiclassical limit and SW curve

By setting  $\nu = 1$  we deduce from the field theory prediction (4.1) that for  $\hbar \rightarrow 0$  the partition function (3.11) has an asymptotic expansion:

$$Z(\mathbf{a}; \hbar, \Lambda) = \exp\left(\sum_{g=0}^{\infty} \hbar^{2g-2} \mathcal{F}_g(\mathbf{a}, \Lambda)\right) \quad (4.2)$$

where

$$\mathcal{F}_0(\mathbf{a}, \Lambda) = -\frac{1}{2} \sum_{l,n} (a_l - a_n)^2 \left(\log\left(\frac{a_l - a_n}{\Lambda}\right) - \frac{3}{2}\right) + \sum_{k=1}^{\infty} \Lambda^{2kN} f_k(\mathbf{a}) \quad (4.3)$$

is the so-called prepotential of the low-energy effective theory. The coefficients  $f_k$  for  $k = 1, 2$  were computed directly from instanton calculus in [38][39], for  $k \leq 5$  in [9].

The prepotential was identified in [3][4][40] with the prepotential of the periodic Toda lattice. The arguments for this identification were indirect. In [41] the coefficients  $f_k$  for  $k \leq 5$  were computed for the Toda prepotential, in agreement with the later results of [9].

The purpose of this paper is to give a proof of this relation to all orders in the instanton expansion.

More precisely, we shall show that:

The set  $\left(a_1, \dots, a_N; \frac{1}{2\pi i} \frac{\partial \mathcal{F}_0}{\partial a_1}, \dots, \frac{1}{2\pi i} \frac{\partial \mathcal{F}_0}{\partial a_N}\right)$  coincides with the set of periods of the differential

$$dS = \frac{1}{2\pi i} z \frac{dw}{w} \quad (4.4)$$

on the curve  $\mathcal{C}_u$  defined by

$$\Lambda^N \left(w + \frac{1}{w}\right) = P_N(z), \quad P_N(z) = z^N + u_1 z^{N-1} + u_2 z^{N-2} + \dots + u_N \quad (4.5)$$

**Remark:** Normally the factor  $2\pi i$  is included in the definition of the prepotential [18]. We chose not to do this to get real expressions for  $\mathcal{F}_0$  for real  $a_l$ 's and  $\Lambda$ .

For generic  $u = (u_1, u_2, \dots, u_N)$  the curve (4.5) is a smooth hyperelliptic curve of genus  $N - 1$ . The differential  $dS$  has poles at two points  $\infty_{\pm}$  over  $x = \infty$ . The homology group

$$H_1(\mathcal{C}_u - \{\infty_+, \infty_-\}; \mathbf{Z})$$

is isomorphic to  $\mathbf{Z} \oplus \mathbf{Z}^{2(N-1)}$ , the first summand being generated by the small loop  $\sigma_{\infty}$  around  $\infty_+$  (the loop around  $\infty_-$  is in the same homology class). The intersection pairing identifies the dual space with

$$H_1(\mathcal{C}_u, \{\infty_+, \infty_-\}; \mathbf{Z}) ,$$

the relative cycle, dual to  $\sigma_{\infty}$  being the path  $\ell^{\infty}$ , connecting  $\infty_-, \infty_+$ .

•

Note that in the  $N$ -parametric family of curves (4.5) there is a set of singular curves. The identification between the periods and  $(a, \frac{\partial \mathcal{F}_0}{\partial a})$  is up to the action of the monodromy group. We need to fix this identification in some open domain of the parameter space.

•

Consider the region  $\mathcal{U}_{\infty}$  of the parameter space, where  $u_s \gg \Lambda^s$ . In this domain the curve (4.5) can be approximately described as follows. Let  $\alpha_1, \dots, \alpha_N$  be the zeroes of the polynomial  $P_N(x)$ :

$$P_N(x) = \prod_{l=1}^N (x - \alpha_l) \tag{4.6}$$

For small  $\Lambda$  for each  $l$  we can unambiguously find  $\alpha_l^{\pm} \approx \alpha_l$ , such that

$$P_N(\alpha_l^{\pm}) = \pm 2\Lambda^N \tag{4.7}$$

These are the branch points of the two-fold covering  $\rho : \mathcal{C}_u \rightarrow \mathbf{P}^1, \mathbf{P}^1 \ni x$ .

•



Let  $\mathbf{a}_l$  be the 1-cycles on  $\mathcal{C}_u$  which are the lifts of the cycles on the  $x$ -plane, which surround the cuts going from  $\alpha_l^-$  to  $\alpha_l^+$ . Let  $\mathbf{b}_l$  be the relative 1-cycle, represented by the path on  $\mathcal{C}_u$  which starts at  $\infty_-$ , goes to  $\alpha_l^+$ , and then goes on the second sheet to  $\infty_+$ . The cycles  $\mathbf{a}_l$ , and  $\mathbf{b}_l$  have canonical intersection pairing:

$$\mathbf{a}_l \cap \mathbf{b}_m = \delta_{lm}. \quad (4.8)$$

The position of the  $\mathbf{a}$ -cycles and  $\mathbf{b}$ -cycles on the curve  $\mathcal{C}_u$  is illustrated on the Fig.1

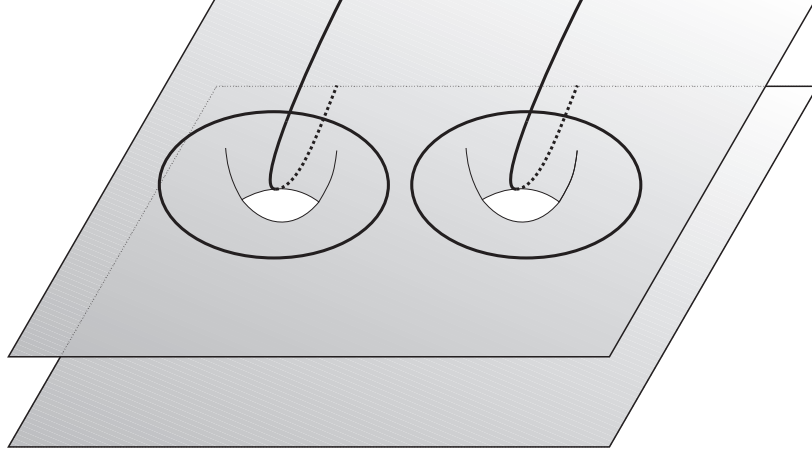

**Fig.1** The curve  $\mathcal{C}_u$  and the cycles on it, the closed ones are  $\mathbf{a}_l$ 's, the noncompact ones are  $\mathbf{b}_l$ 's

The cycles  $\sigma_\infty$  and  $\ell^\infty$  are related to  $\mathbf{a}_l, \mathbf{b}_m$  via:

$$\sigma_\infty = \sum_l \mathbf{a}_l, \quad \ell^\infty = \sum_l \mathbf{b}_l \quad (4.9)$$

The periods  $a_l$  and  $\frac{\partial \mathcal{F}_0}{\partial a_l}$  are defined via:

$$a_l = \oint_{\mathbf{a}_l} dS, \quad \frac{\partial \mathcal{F}_0}{\partial a_l} = 2\pi i \int_{\mathbf{b}_l(\mu)} dS \quad (4.10)$$

where  $\mathbf{b}_l(\mu)$  is the regularized contour of integration, which connects  $w|_{z=\mu}$  and  $w^{-1}|_\mu$  instead of  $\infty_+$  and  $\infty_-$ .

•

The divergent (with  $\mu$ ) part of the periods is easy to calculate:

$$\frac{1}{2\pi i} \frac{\partial \mathcal{F}_0}{\partial a_l} = 2N\mu - u_1 \log(\mu) + \text{finite part} \quad (4.11)$$

At the same time:

$$\oint_{\sigma_\infty} dS = a = \sum_l a_l = -u_1 \quad (4.12)$$

As we said above, in the sequel we set  $a = 0 = u_1$ . Also, to avoid worrying about the cut-off we work with the absolute cycles  $\mathbf{b}_l - \mathbf{b}_{l+1}$ .



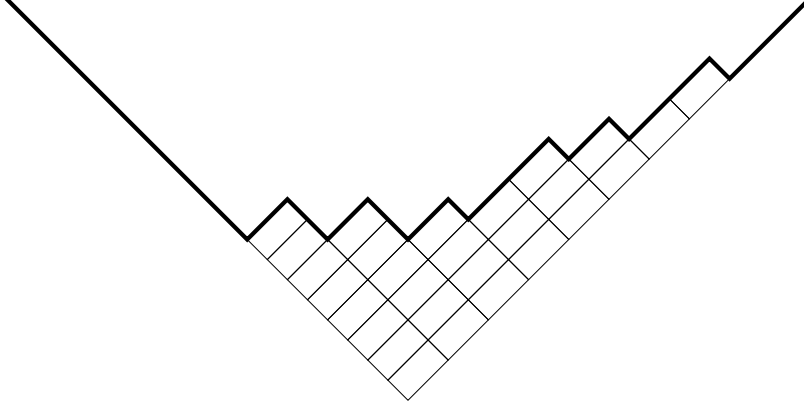

**Fig.3** Squeezed Young diagram

We have

$$\begin{aligned}
f_{\mathbf{k}}(x|\epsilon_1, \epsilon_2) &= |x| + \sum_{i=1}^{\infty} \left[ |x + \epsilon_1 - \epsilon_2 k_i - \epsilon_1 i| - |x - \epsilon_2 k_i - \epsilon_1 i| \right. \\
&\quad \left. - |x + \epsilon_1 - \epsilon_1 i| + |x - \epsilon_1 i| \right] \\
&= |x| + \sum_{j=1}^{\infty} \left[ |x + \epsilon_2 - \epsilon_1 \tilde{k}_j - \epsilon_2 j| - |x - \epsilon_1 \tilde{k}_j - \epsilon_2 j| \right. \\
&\quad \left. - |x + \epsilon_2 - \epsilon_2 j| + |x - \epsilon_2 j| \right]
\end{aligned} \tag{4.14}$$

By construction, the profile of a partition satisfies

$$\begin{aligned}
f'_{\mathbf{k}}(x|\epsilon_1, \epsilon_2) &= \pm 1, \\
f_{\mathbf{k}}(x|\epsilon_1, \epsilon_2) &\geq |x|, \\
f_{\mathbf{k}}(x|\epsilon_1, \epsilon_2) &= |x|, \text{ for } |x| \gg 0.
\end{aligned} \tag{4.15}$$

We also define the profile of a charged partition

$$f_{a;\mathbf{k}}(x|\epsilon_1, \epsilon_2) = f_{\mathbf{k}}(x - a|\epsilon_1, \epsilon_2)$$

The charge and the size are easily recovered from  $f_{a;\mathbf{k}}(x)$ :

$$\begin{aligned}
a &= \frac{1}{2} \int_{\mathbf{R}} dx x f''_{a;\mathbf{k}}(x|\epsilon_1, \epsilon_2) = -\frac{1}{2} \int_{\mathbf{R}} dx f'_{a;\mathbf{k}}(x|\epsilon_1, \epsilon_2), \\
|\mathbf{k}| &= \frac{a^2}{2\epsilon_1\epsilon_2} - \frac{1}{4\epsilon_1\epsilon_2} \int dx x^2 f''_{a;\mathbf{k}}(x|\epsilon_1, \epsilon_2) = \frac{1}{2\epsilon_1\epsilon_2} \left( a^2 - \int dx (f_{a;\mathbf{k}}(x|\epsilon_1, \epsilon_2) - |x|) \right)
\end{aligned} \tag{4.16}$$

Here and in what follows, we denote by

$$\oint_D g(x) dx = \lim_{L \rightarrow \infty, \delta \rightarrow 0} \int_{D \cap [-L, L] \setminus \text{sing}_\delta(g)} g(x) dx$$

the principal value integral over a domain  $D \subset \mathbf{R}$ , where  $\text{sing}_\delta(g)$  denotes the  $\delta$ -neighborhood of the singularities of  $g(x)$ .

•

For a colored partition  $\vec{\mathbf{k}}$  and a vector  $\mathbf{a}$  we define:

$$f_{\mathbf{a}; \vec{\mathbf{k}}}(x | \epsilon_1, \epsilon_2) = \sum_{l=1}^N f_{a_l; \mathbf{k}_l}(x | \epsilon_1, \epsilon_2) \quad (4.17)$$

For example, for  $\epsilon_2 = -\epsilon_1 = \hbar$ ,  $a_1 = -a_2 = 11\hbar$  and the partition

$$\{(7, 4, 3, 3, 2, 1), (8, 7, 4, 4, 3, 1)\}$$

the corresponding profile looks as follows:

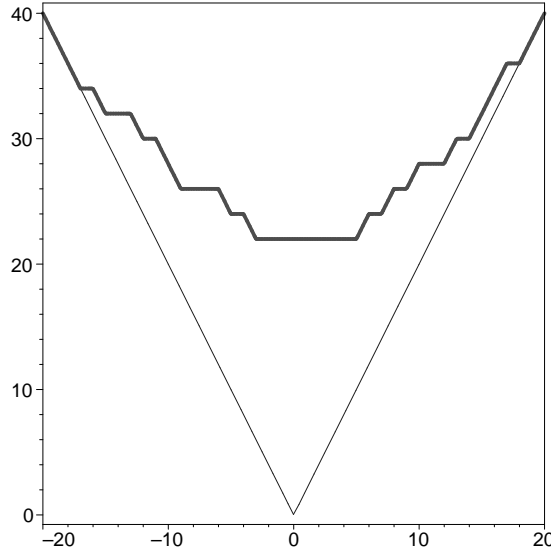

**Fig.4** The profile of the colored partition  $\{(7, 4, 3, 3, 2, 1), (8, 7, 4, 4, 3, 1)\}$

### 4.3. Vacuum expectation values and resolvents

The profile function is natural from the gauge theory point of view: the vacuum expectation values of the single trace operators  $\text{Tr} \phi^n$  have a simple expression in terms of the profiles:

$$\langle \text{Tr} \phi^n \rangle_{\mathbf{a}} = \frac{1}{Z(\mathbf{a}; \epsilon_1, \epsilon_2, \Lambda)} \sum_{\vec{\mathbf{k}}} \Lambda^{2N|\vec{\mathbf{k}}|} Z_{\vec{\mathbf{k}}}(\mathbf{a}; \epsilon_1, \epsilon_2, \Lambda) \mathcal{O}_n[\vec{\mathbf{k}}] \quad (4.18)$$

where

$$\mathcal{O}_n[\vec{\mathbf{k}}] = \frac{1}{2} \int_{\mathbf{R}} dx x^n f''_{\mathbf{a};\vec{\mathbf{k}}}(x|\epsilon_1, \epsilon_2) \quad (4.19)$$

The second derivative  $f''$  of a partition profile is a compactly supported distribution on  $\mathbf{R}$  which for random partitions plays to the role similar the role of the spectral measure for random matrices. In particular, it is convenient to introduce the resolvent  $R(z|\epsilon_1, \epsilon_2)$  of a colored partition  $\vec{\mathbf{k}}$  by

$$R(z|\epsilon_1, \epsilon_2) = \frac{1}{2} \int_{\mathbf{R}} dx \frac{f''_{\mathbf{a};\vec{\mathbf{k}}}(x|\epsilon_1, \epsilon_2)}{z - x}. \quad (4.20)$$

Note that:

$$R(z|\epsilon_1, \epsilon_2) = \frac{N}{z} + \frac{a}{z^2} + O\left(\frac{1}{z^3}\right), \quad z \longrightarrow \infty \quad (4.21)$$

In our context, the limit shapes  $f$  of partitions will be convex piece-wise analytic functions for which the second derivative  $f''(x)$  will be positive and compactly supported.

#### 4.4. Real vs. complex

In the gauge theory the vacuum expectation values  $a_l$  of the Higgs field are, in general, complex. In this case the profile function  $f_{\mathbf{a};\vec{\mathbf{k}}}$  does not make sense. However, the resolvent (4.20) of a colored partition is well-defined and can be effectively used in the analysis below. The formula (4.19) is replaced by:

$$\mathcal{O}_n[\vec{\mathbf{k}}] = \frac{1}{2\pi i} \oint z^n R(z|\epsilon_1, \epsilon_2) dz \quad (4.22)$$

where the contour goes around  $z = \infty$ .

Complex values of  $a_l$  can be reached from the real values by analytic continuation. By the same token, it is enough to analyze the problem for values of  $a_l$  in any open set of  $\mathbf{R}^N$ . In particular, it is enough to analyze the problem in the asymptotic domain  $\mathcal{U}_\infty$ , which is what we will do next.

#### 4.5. The thermodynamic limit

Our strategy in extracting the  $\epsilon_1, \epsilon_2 \rightarrow 0$  limit of the sum (3.5) is the following. The typical size of the partition  $\mathbf{k}$  contributing to the sum is of the order  $|\mathbf{k}| \sim \frac{1}{\epsilon_1 \epsilon_2}$ , and is so large that the sum over the partitions can be approximated by an integral over the

space of continuous Young diagrams  $f(x)$ . A continuous Young diagram, by definition, is a function satisfying the following weakening of the condition (4.15)

$$\begin{aligned}
f(x) &= |x|, & |x| &\gg 0, \\
|f(x) - f(y)| &\leq |x - y|, \\
\int_{\mathbf{R}} dx f'(x) &= 0, \\
\int_{\mathbf{R}} dx (f(x) - |x|) &< \infty
\end{aligned} \tag{4.23}$$

Note that the condition  $f'(x) = \pm 1$  is replaced by the weaker Lipschitz condition.

We will show that this path integral is dominated by a unique saddle point (in fact, a strict maximum). In a more mathematical language, this means the following. By associating to every partition its profile, we get from (3.5) a measure on the space of Lipschitz functions. As  $\epsilon_1, \epsilon_2 \rightarrow 0$ , these measures concentrate around a single point, that is, converge to the delta measure at a single function. This function is the limit shape of our random partition. We will construct this limit shape explicitly and show that it has a very simple and direct relation to the Seiberg-Witten geometry.

•

We begin by observing that the Plancherel measure  $\mu(\mathbf{k})$  can be written in terms of profile  $f_{\mathbf{k}}(x|\hbar)$  as follows

$$\mu(\mathbf{k}) = \exp \left( -\frac{1}{8} \int_{x \neq y} f_{\mathbf{k}}''(x|\hbar) f_{\mathbf{k}}''(y|\hbar) \gamma_{\hbar}(x - y; \Lambda) dx dy \right). \tag{4.24}$$

More generally, we have

$$Z_{\vec{\mathbf{k}}}(\mathbf{a}; \epsilon_1, \epsilon_2, \Lambda) = \exp \left( -\frac{1}{4} \int dx dy f_{\mathbf{a}, \vec{\mathbf{k}}}''(x|\epsilon_1, \epsilon_2) f_{\mathbf{a}, \vec{\mathbf{k}}}''(y|\epsilon_1, \epsilon_2) \gamma_{\epsilon_1, \epsilon_2}(x - y, \Lambda) \right), \tag{4.25}$$

as can be easily checked with the help of the main difference equation. Denoting the right-hand side of (4.25) by  $Z_f(\epsilon_1, \epsilon_2, \Lambda)$ , we have

$$Z(\mathbf{a}; \epsilon_1, \epsilon_2, \Lambda) = \sum_{f \in \Gamma_{\mathbf{a}}^{discrete}} Z_f(\epsilon_1, \epsilon_2, \Lambda), \tag{4.26}$$

where the summation is over the set  $\Gamma_{\mathbf{a}}^{discrete}$  of paths of the form  $f = f_{\mathbf{a}, \vec{\mathbf{k}}}$ .

When  $\epsilon_1, \epsilon_2 \rightarrow 0$  with  $\nu$  fixed, the size of a typical partition  $\mathbf{k}_l$  in (4.26) grows like  $|\mathbf{k}_l| \sim \frac{1}{\epsilon_1 \epsilon_2}$ . In this limit, the sum (4.26) looks like an integral, over the space  $\Gamma_{\mathbf{a}}$  of paths  $f$  of the form

$$f(x) = \sum_{l=1}^N f_l(x - a_l) \quad (4.27)$$

with each  $f_l$  satisfying (4.23). For this integral,  $\epsilon_1 \epsilon_2$  plays the rôle of the Planck constant. Our strategy, therefore, is to find a saddle point (in fact, the minimum) of the action

$$\mathcal{E}_{\Lambda}(f) = \frac{1}{4} \int_{y < x} dx dy f''(x) f''(y) (x - y)^2 \left( \log \left( \frac{x - y}{\Lambda} \right) - \frac{3}{2} \right) \quad (4.28)$$

on the space  $\Gamma_{\mathbf{a}}$  of paths (4.27). The action (4.28) is the leading term as  $\epsilon_1, \epsilon_2 \rightarrow 0$  of the action in (4.25):

$$Z_f(\mathbf{a}; \epsilon_1, \epsilon_2, \Lambda) \sim \exp \left( \frac{1}{\epsilon_1 \epsilon_2} \mathcal{E}_{\Lambda}(f) \right) \quad (4.29)$$

Integrating by parts we rewrite (4.28) as

$$\mathcal{E}_{\Lambda}(f) = -\frac{1}{2} \int_{x < y} (N + f'(x))(N - f'(y)) \log \left( \frac{y - x}{\Lambda} \right) dx dy \quad (4.30)$$

which, for  $N = 1$ , reproduces the result of Logan-Schepp-Kerov-Vershik[42][43][44][45]. Thus, we have:

$$\mathcal{F}_0(\mathbf{a}, \Lambda) = -\text{Crit}_{f \in \Gamma_{\mathbf{a}}} \mathcal{E}_{\Lambda}(f) \quad (4.31)$$

#### 4.5.1. Profiles vs. eigenvalue densities

In [9] an expression for  $Z_k(\mathbf{a}, \epsilon_1, \epsilon_2) = \sum_{\vec{\mathbf{k}}, |\vec{\mathbf{k}}|=k} Z_{\vec{\mathbf{k}}}$  was given in terms of some contour integral over  $k$  eigenvalues  $\phi_I$ ,  $I = 1, \dots, k$ . This expression follows straightforwardly from the ADHM construction of the moduli space of instantons, and, therefore, easily generalizes to the case of  $SO, Sp$  gauge groups. It is, therefore, quite remarkable that the formula (4.29) can be obtained directly from the contour integral expression, avoiding the actual evaluation of the integral (which is, of course, needed to get correctly the  $\mathcal{F}_g$ 's with  $g > 0$ ).

$$Z_k(\mathbf{a}, \epsilon_1, \epsilon_2) = \oint \prod_{I=1}^k \left[ \frac{\epsilon_1 + \epsilon_2}{2\pi\epsilon_1\epsilon_2} \frac{d\phi_I}{P(\phi_I)P(\phi_I + \epsilon_1 + \epsilon_2)} \right] \prod_{I \neq J} \frac{\phi_{IJ}(\phi_{IJ} + \epsilon_1 + \epsilon_2)}{(\phi_{IJ} + \epsilon_1)(\phi_{IJ} + \epsilon_2)} \quad (4.32)$$

where

$$P(x) = \prod_{l=1}^N (x - a_l) \quad (4.33)$$

$$\phi_{IJ} = \phi_I - \phi_J$$

We now multiply  $Z_k$  by  $\Lambda^{2kN}$  and sum over  $k = 0, 1, \dots$ , to get  $Z^{inst}$ . Take the limit  $\epsilon_1, \epsilon_2 \rightarrow 0$ . The typical  $k$  which will contribute most to the sum will be of the order  $k \sim \frac{1}{\epsilon_1 \epsilon_2}$ . So we introduce the density of eigenvalues:

$$\rho(x) = \epsilon_1 \epsilon_2 \sum_{I=1}^k \delta(x - \phi_I) \quad (4.34)$$

which is normalized in a  $k$ -independent way, which nevertheless guarantees its finiteness in the limit we are taking. Now, the difference with the ordinary 't Hooft-like limit of the ordinary matrix integrals is the presence of the equal number of the  $\phi_{IJ}$  terms in the numerator and the denominator of the measure (4.32). This will change qualitatively the density dependence of the effective potential on the eigenvalues, and the resulting equilibrium distribution of the eigenvalues. In particular in our limit the former supersymmetric matrix integral (4.32) scales as  $\exp kF$  as opposed to the 't Hooft's  $\exp k^2 F$ .

Nevertheless we have a sharp peak in the measure, which justifies the application of the saddle point method. Indeed, by expanding in  $\epsilon_1, \epsilon_2$  we map the measure in (4.32) onto:

$$\Lambda^{2kN} Z_k(\mathbf{a}, \epsilon_1, \epsilon_2) \sim \exp \left( \frac{1}{\epsilon_1 \epsilon_2} \mathbf{E}_\Lambda[\rho] \right) \quad (4.35)$$

where

$$\mathbf{E}_\Lambda[\rho] = - \int_{x \neq y} dx dy \frac{\rho(x)\rho(y)}{(x-y)^2} - 2 \int dx \rho(x) \log \left( \frac{P(x)}{\Lambda^N} \right) \quad (4.36)$$

Up to the perturbative piece

$$\frac{1}{2} \sum_{l,n} (a_l - a_n)^2 \log \left( \frac{a_l - a_n}{\Lambda} \right)$$

the energy (4.36) coincides with the action (4.28) if we identify:

$$f(x) - \sum_{l=1}^N |x - a_l| = \rho(x)$$

(4.37)

The same method applies to other theories considered in [9][46].

Thus we have learned yet another interpretation of the limiting profile of the colored partition. In the rest of the paper we shall work with limit profiles, as the equations on the extremum are identical to those following from (4.36).



### 4.5.2. Surface tension

Given a function  $f(x)$  as in (4.27), how can we extract  $a_l$ 's? This is easy to do in the region  $\mathcal{U}_\infty$  where

$$a_l \ll a_{l+1},$$

in which case the supports of the functions  $f_{a_l, \mathbf{k}_l}$  do not intersect. Introduce parameters  $\xi_1, \dots, \xi_N$  which will play the role of dual variables to the charges  $a_l$ . From (4.16) we have the following

**Proposition 1** For  $a_l \ll a_{l+1}$  we have

$$\sum_l \xi_l a_l = -\frac{1}{2} \int_{\mathbf{R}} \sigma(f'(x)) dx,$$

where  $\sigma(y)$  is a concave, piecewise-linear function on  $[-N, N]$  such that

$$\sigma'(y) = \xi_l, \quad y \in [-N + 2(l-1), -N + 2l],$$

and

$$\sigma(-N) = -\sigma(N) = -\sum_l \xi_l.$$

An example of the graph of  $\sigma$  is plotted on the Fig.5

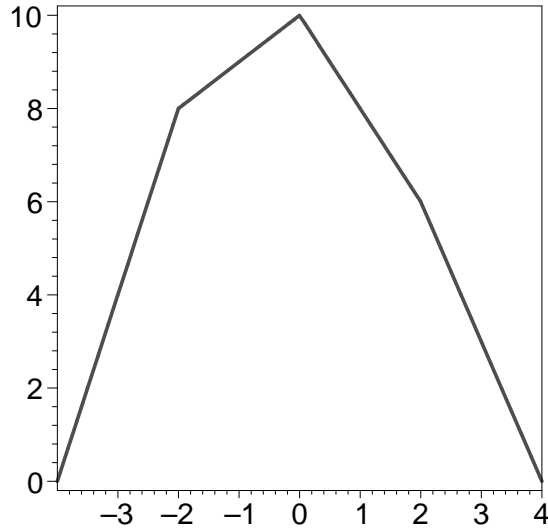

**Fig.5** Surface tension for  $\xi = (4, 1, -2, -3)$

In Section 5, we define a dual partition function  $Z^D(\xi, \hbar, \Lambda)$ . We will see that the dual partition function  $Z^D$  can be interpreted in terms of a periodically weighted (with

period  $N$ ) Plancherel measure on partitions. The periodic weights in this formalism are precisely  $e^{\xi_l}$  and the function  $\sigma$  becomes the corresponding surface tension function.

This story has many parallels and direct connections to the theory of periodically weighted planar dimers developed in [47].

It is a general principle that singularities of surface tension (usually referred to as “cusps”) correspond to flat regions (“crystal facets”) of the corresponding action minimizing shapes. In our case, the singularities of the function  $\sigma$  correspond to gaps between the supports of the functions  $f_{\star,l}(x - a_l)$  for the minimizer  $f_{\star}(x)$ .

#### 4.6. The equations for the limiting shape

In order to minimize  $\mathcal{E}(f)$  with fixed  $a_l$ 's, we introduce Lagrange multipliers  $\xi_l$ , which we order as

$$\xi_1 > \dots > \xi_N, \tag{4.38}$$

and look for the maximizer of the total action

$$\mathcal{S}_{\Lambda}(f) = -\mathcal{E}_{\Lambda}(f) + \frac{1}{2} \int \sigma(f'(x)) dx \tag{4.39}$$

for fixed values of the  $\xi_l$ 's. To get back the minimum of  $\mathcal{E}(f)$  with fixed  $a_l$  we shall later perform the Legendre transform with respect to  $\xi_l$ 's. Note that the surface tension term  $\frac{1}{2} \int \sigma(f')$  in (4.39) under the conditions  $a = 0$  and (4.38) can be made arbitrarily large by making the individual profiles  $f_l$  sufficiently separated from each other. The price one pays for this is the decrease in the “energy” term  $-\mathcal{E}_{\Lambda}(f)$ , thus there is a competition between the two terms in (4.39) which leads to the global maximum.

The action (4.39) is a concave functional. In fact, the first term in (4.39) is strictly concave (with proper boundary conditions), which can be seen by rewriting it as a certain Sobolev norm, see [44]. Therefore, any critical point of the action  $\mathcal{S}(f)$  is automatically a global minimizer. It is, therefore, enough to look at the first variation of (4.39). Because of the singularities of  $\sigma$ , this first variation will involve the one-sided derivatives.

•

Taking the first variation and integrating once by parts, we find the following equation:

$$\int_{y \neq x} dy (y - x) \left( \log \left| \frac{y - x}{\Lambda} \right| - 1 \right) f''(y) = \sigma'(f'(x)) . \tag{4.40}$$

This equation should be satisfied for any point  $x$ , for which  $f'(x)$  is a point of continuity of  $\sigma'$ . When

$$f'(x) \in \{-N + 2l \mid l = 1, \dots, N - 1\}$$

then considering the left and right derivatives separately we obtain the inequalities

$$\mathbf{X}f(x) \in (\sigma'(f'(x) - 0), \sigma'(f'(x) + 0)) , \quad (4.41)$$

where, by definition,

$$[\mathbf{X}f](x) = \int_{y \neq x} dy (y - x) \left( \log \left| \frac{y - x}{\Lambda} \right| - 1 \right) f''(y) \quad (4.42)$$

The transform  $\mathbf{X}f$  is closely related to the standard Hilbert transform

$$[\mathbf{H}g](x) = \frac{1}{\pi} \int_{y \neq x} dy \frac{g(y)}{y - x}. \quad (4.43)$$

Indeed,

$$[\mathbf{X}f]'' = \pi \mathbf{H}(f''). \quad (4.44)$$

With  $\xi_0 = +\infty, \xi_{N+1} = -\infty$ , the conditions (4.40) and (4.41) can be recast in the following form:

**Proposition 2** A function  $f_*(x)$  is a critical point of  $\mathcal{S}(f)$  iff

$$\begin{aligned} \mathbf{X}f_*(x) = \xi_l \quad \text{whenever} \quad -N + 2l - 2 < f_*'(x) < -N + 2l \\ \xi_l > \mathbf{X}f_*(x) > \xi_{l+1} \quad \text{whenever} \quad f_*'(x) = -N + 2l, \quad l = 0, \dots, N \end{aligned} \quad (4.45)$$

In other words, the function

$$\varphi(x) = f_*'(x) + \frac{1}{\pi i} [\mathbf{X}f_*]'(x) \quad (4.46)$$

defines a map from  $\mathbf{R}$  to the boundary of the domain  $\Delta$  depicted on Fig. 6. We now describe the solution to (4.45) in great detail.

## 4.7. Construction of the maximizer

Let  $\Phi(z)$  be the conformal map from the upper half-plane to the domain  $\Delta$  which is the half-strip

$$\Delta = \{\varpi \mid |\Re(\varpi)| < N, \Im(\varpi) > 0\} \quad (4.47)$$

with vertical slits along

$$\{\Re(\varpi) = -N + 2l, \Im(\varpi) \in [0, \eta_l]\}, \quad l = 1, \dots, N - 1. \quad (4.48)$$

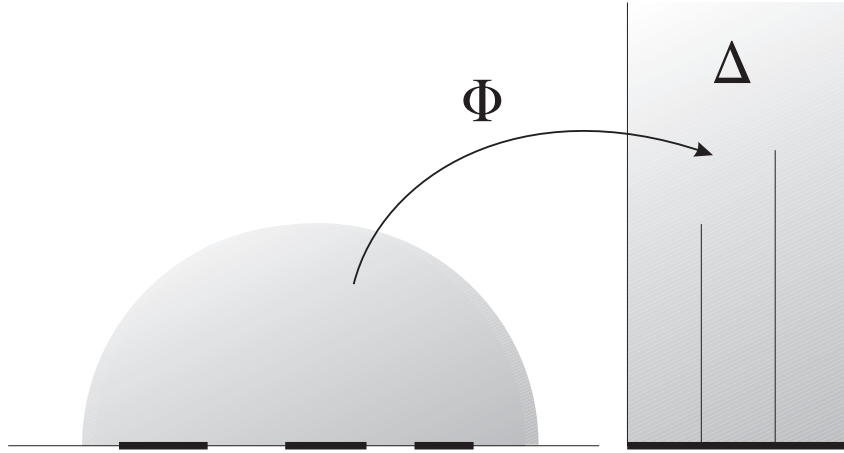

**Fig.6** Conformal map for  $N = 3$

The positive reals  $\eta_l$ ,  $l = 1 \dots N - 1$ , are the parameters of function  $\Phi$ . We normalize  $\Phi$  by the condition that it maps infinity to infinity and

$$\Phi(z) = N + \frac{2N}{\pi i} \log \frac{\Lambda}{z} + O\left(\frac{1}{z}\right), \quad z \rightarrow \infty. \quad (4.49)$$

This fixes  $\Phi$  up to an overall shift  $x \mapsto x + \text{const}$ . This ambiguity is related to the overall shift of the limit shape (and hence, to the overall charge of our colored partition) and is immaterial.

### 4.7.1. Construction of the conformal map

The map  $\Phi$  can be, of course, found using the Schwarz-Christoffel formula, but it is easier to construct is as the following sequence of elementary conformal maps.

We take  $P_N(z)$  to be a monic real polynomial

$$P_N(z) = z^N + \dots$$

such that all roots  $\alpha_l^\pm$  of the equation

$$P_N(z)^2 - 4\Lambda^{2N} = \prod_{l=1}^N (z - \alpha_l^+)(z - \alpha_l^-) \quad (4.50)$$

are real. Let  $w$  be the smaller root of the equation

$$\Lambda^N \left( w + \frac{1}{w} \right) = P_N(z). \quad (4.51)$$

The function

$$w \mapsto \Lambda^N \left( w + \frac{1}{w} \right)$$

is known as the Zhukowski function and it maps the open disk  $|w| < 1$  to the exterior of the segment  $[-2\Lambda^N, 2\Lambda^N]$ . It also maps reals to reals, and therefore the smaller root of (4.51) maps the upper half-plane to the disk  $|w| < 1$  with slits along the real axis. It remains to take logarithm to obtain the map  $\Phi$ . Concretely,

$$\Phi(z) = \frac{2}{\pi i} \log(w) + N, \quad (4.52)$$

where  $w$  is the smaller root of the equation (4.51) and we take the branch of the logarithm satisfying

$$\Im \log(w) \rightarrow 0, \quad z \rightarrow +\infty.$$

Since

$$w \sim \frac{\Lambda^N}{z^N}, \quad z \rightarrow \infty$$

we get the normalization condition (4.49).

#### 4.7.2. Example: $N = 2$

As an example, consider the case  $N = 2$

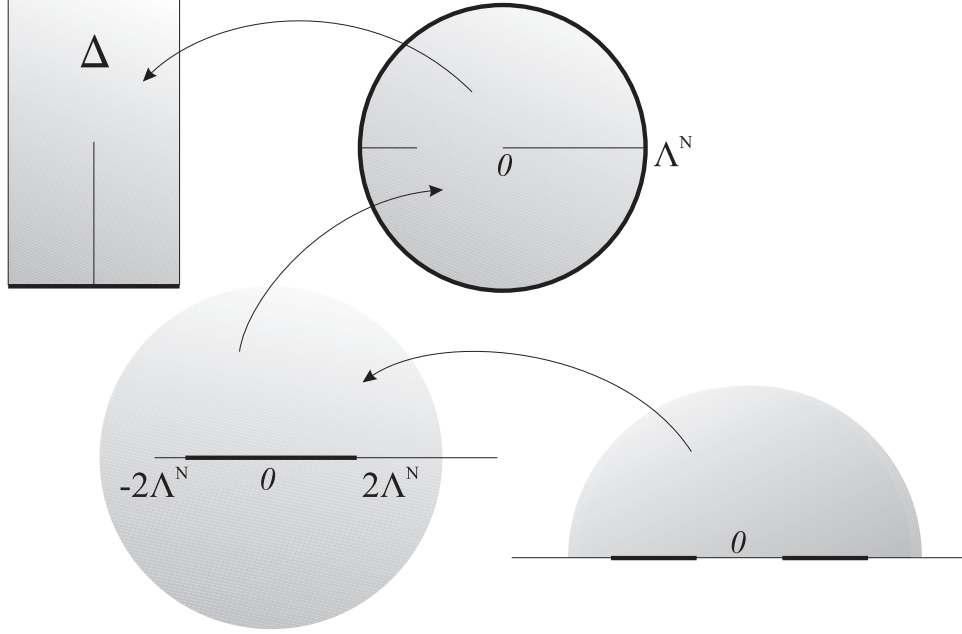

**Fig.7** A sequence of maps for  $N = 2$

A real quadratic polynomial

$$P_2(z) = z^2 + \dots$$

maps the upper half-plane to the entire complex plane with a cut along the ray

$$\left[ \min_{x \in \mathbf{R}} P_2(x), +\infty \right).$$

In particular, if the  $\min_{\mathbf{R}} P_2(x) < -2\Lambda^2$ , that is, if both roots of

$$P_2(x) = -2\Lambda^2$$

are real then the segment  $[-2\Lambda^2, 2\Lambda^2]$  is contained in this cut.

### 4.7.3. Gaps and bands

For general  $N$ , the only difference with the  $N = 2$  case is that the map  $P_N$  winds the upper half-plane  $N/2$  times around the complex plane. Correspondingly, the root of (4.51) lives on a certain cover of the disk  $|w| < 1$ , which then gets unfolded by the logarithm.

Observe that the conformal map  $\Phi(z)$  has a well-defined extension to the boundary  $\mathbf{R}$  of the upper half-plane

$$\varphi(x) = \Phi(x + i0),$$

where the notation is consistent with (4.46).

We label the roots of (4.50) so that the union of the intervals  $[\alpha_l^-, \alpha_l^+]$  is the preimage of the base of the half-strip  $\Delta$  under the map  $\varphi$ , that is

$$\varphi^{-1}([-N, N]) = \bigcup_{l=1}^N [\alpha_l^-, \alpha_l^+]. \quad (4.53)$$

These intervals are plotted in bold in the above figures. We will call these intervals the *bands* of  $\Phi$  and the complementary intervals — the *gaps* of  $\Phi$ .

**Proposition 3** We claim that for a choice of  $\xi_l$ 's in (4.38) we can find the corresponding values of  $\eta_l$ ,  $l = 1, \dots, N$ , such that the function  $f_*$  satisfying

$$\boxed{f_*'(x) = \Re \varphi(x)}, \quad (4.54)$$

is the maximizer of the action  $\mathcal{S}(f)$ . The bands and gaps of  $\Phi$  will correspond to the curves and flat parts of the limit shape  $f_*$ , respectively. They will also correspond to the bands and gaps in the spectrum of the Lax operator for the periodic Toda chain, as will be explained in the next section.

•

Let us apply the Schwarz reflection principle to any vertical part of the boundary of  $\Delta$  and the corresponding piece of the real axis in the domain of  $\Phi$ . Taking the resulting function modulo 2, we obtain an  $N$ -fold covering map

$$\Phi \bmod 2 : \mathbf{C} \setminus \bigcup_{l=1}^N [\alpha_l^-, \alpha_l^+] \rightarrow \{\Im \varpi > 0\} / \bmod 2 \quad (4.55)$$

from the complex plane minus the bands to the half-infinite cylinder, shown schematically on Fig.8.

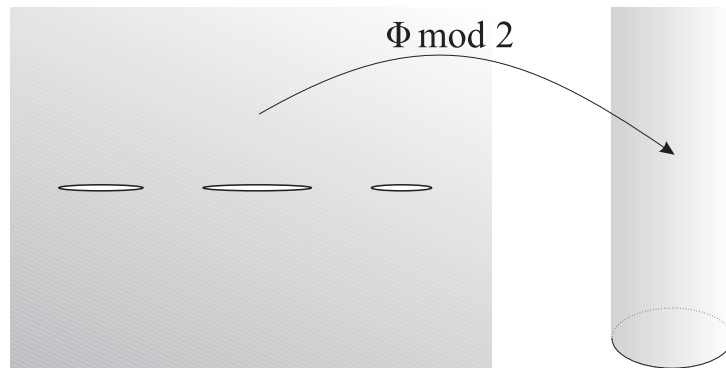

**Fig.8** Covering half-cylinder

Note that this map has square-root branching precisely over the points  $i\eta_l$ ,  $l = 1, \dots, N-1$ . It follows that  $\Phi'(z)$  extends to an analytic function in the complement of the bands. By the reflection principle, the value of  $\Phi'(z)$  on the other side of the cut is precisely  $-\Phi'(z)$ . Also note that  $\Phi'(z)$  is real (resp. purely imaginary) on bands (resp. gaps). We conclude that

$$\Phi'(z) = \frac{1}{\pi i} \int_{\mathbf{R}} \frac{\Re \varphi'(x)}{x-z} dx = -\frac{2}{\pi i} R_{f_\star}(z), \quad (4.56)$$

where  $R_{f_\star}(z)$  is ( $\epsilon_1, \epsilon_2 \rightarrow 0$  limit of) the resolvent of the limit profile  $f_\star$ , defined by (4.54). We can, therefore, identify:

$$l\text{th band} \equiv [\alpha_l^-, \alpha_l^+] = \text{supp} f_l''(x - a_l), \quad l = 1, \dots, N \quad (4.57)$$

#### 4.7.4. Periods

It follows from (4.56) that

$$a_l = \frac{1}{2\pi i} \oint_{\mathbf{a}_l} z R_{f_\star}(z) dz = \oint_{\mathbf{a}_l} dS \quad (4.58)$$

where we used (4.52), and, in agreement with (4.4), we have defined Seiberg-Witten differential:

$$\boxed{dS = \frac{1}{2\pi i} z \frac{dw}{w}} \quad (4.59)$$

•

Taking the average of  $\Phi'(z)$  on two sides of the cut in (4.56), we get

$$\mathbf{H} \Re \varphi'(x) = -\Im \varphi'(x). \quad (4.60)$$

Using (4.44), we conclude from (4.60) that

$$[\mathbf{X}f_\star]'(x) = -\pi \Im \varphi(x) + \text{const}.$$

We claim that this constant is, in fact, zero. Indeed, we have

$$[\mathbf{X}f_\star]'(x) = - \int \log \left( \frac{|y-x|}{\Lambda} \right) f''(y) dy = 2N \log \left( \frac{\Lambda}{|x|} \right) + O \left( \frac{1}{x} \right), \quad x \rightarrow \infty \quad (4.61)$$



Comparing this to (4.49), we conclude that

$$[\mathbf{X}f_\star]'(x) = -\pi\Im\varphi(x). \quad (4.62)$$

Since, clearly,  $\Im\varphi(x) \geq 0$  and  $\Im\varphi(x)$  vanishes on the bands, it follows from (4.62) that  $\mathbf{X}f_\star$  is monotone decreasing and constant on the bands. It is also clear that the function (4.54) is monotone increasing and constant on the gaps, where it takes the values

$$-N + 2l, \quad l = 0, \dots, N.$$

This verifies the conditions (4.45) with  $\xi_l$ 's being the values of  $\mathbf{X}f_\star$  on the bands.

•

To recover the  $\xi_l$ 's we just integrate  $[\mathbf{X}f_\star]'$  along the gap, where

$$i\Im\varphi(x) = \varphi(x) + \text{const}.$$

We find

$$\xi_{l+1} - \xi_l = -\pi \int_{\alpha_l^+}^{\alpha_{l+1}^-} \Im\varphi(x) dx = -\pi i \int_{\alpha_l^+}^{\alpha_{l+1}^+} x d\varphi(x),$$

integrating by parts and using the vanishing of  $\Im\varphi(x)$  at the endpoints of a gap. In terms of the Seiberg-Witten differential and the cycles  $\mathbf{b}_l$  the last relation reads as:

$$\xi_l - \xi_{l+1} = 2\pi i \oint_{\mathbf{b}_l - \mathbf{b}_{l+1}} dS \quad (4.63)$$

This together with the overall constraint  $\sum \xi_l = 0$  fixes the values of the  $\xi_l$ 's.

#### 4.7.5. Completeness

We now show that by a suitable choice of the slit-lengths  $\eta_l$  we can achieve any value of the parameters (4.38). The period map

$$\mathbf{R}_{>0}^{N-1} \ni (\eta_1, \dots, \eta_{N-1}) \mapsto (\xi_1 > \dots > \xi_N), \quad (4.64)$$

is an continuous (in fact, analytic) map of open sets of  $\mathbf{R}^{N-1}$ . Because of the uniqueness of the maximizer  $f_\star$ , this map is one-to-one. Hence, if we can additionally show that it maps boundary to boundary, it will follow that this map is onto.

It is clear that if  $\eta_l \rightarrow 0$  for some  $l$  then  $\xi_l - \xi_{l+1} \rightarrow 0$ . Suppose that for some  $n = 1, \dots, N$ ,

$$\eta_n = \max_l \eta_l \rightarrow +\infty$$

It is clear from the electrostatic interpretation of the conformal map  $\Phi$  that the tip of the  $n$ -th slit will not be screened by other slits, that is, for some constants  $\delta_1, \delta_2 > 0$  we have

$$\int_{x \in [\alpha_l^+, \alpha_l^-], \Im \Phi(x) > (\eta_n - \delta_1)} dx > \delta_2,$$

whence

$$\xi_l - \xi_{l+1} = \int_{[\alpha_l^+, \alpha_l^-]} \Im \Phi(x) dx > \delta_2(\eta_n - \delta_1) \rightarrow \infty.$$

#### 4.7.6. Periods and the prepotential

We now perform a check. We consider the partials

$$\frac{\partial \mathcal{S}(f_\star)}{\partial \xi_l} \tag{4.65}$$

and relate them to the  $A$ -periods  $a_l$  (4.58) of the differential  $dS$ .

We have

$$\frac{\partial}{\partial \xi_l} \mathcal{S}(f_\star) = \left[ \frac{\partial}{\partial \xi_l} \mathcal{S} \right] (f_\star) \tag{4.66}$$

because any infinitesimal change in  $f_\star$  can only decrease the value of  $\mathcal{S}(f_\star)$  which forces the variation of  $\mathcal{S}$  due to the change in  $f_\star$  to vanish (this is essentially a usual argument about the variation of the critical value of the action with respect to the parameters of action). The rest is trivial:

$$\begin{aligned} \delta \mathcal{S}(f_\star) &= \frac{1}{2} \int [\delta \sigma](f_\star') dx = -\frac{1}{2} \int [\delta \sigma]'(f_\star') x f_\star''(x) dx = \\ &= -\frac{1}{2} \sum_l \delta \xi_l \int_{\alpha_l^-}^{\alpha_l^+} x f_\star''(x) dx = \\ &= -\frac{1}{4} \sum_l \delta \xi_l \oint_{\mathbf{a}_l} z d\Phi(z) \end{aligned} \tag{4.67}$$

which is exactly what we wanted, given (4.52)(4.59).

•



Here  $P(z)$  is a monic polynomial of degree  $N$ . Observe that all roots of the polynomials

$$P(z) \pm 2\Lambda^N = \det(z - L(\mp 1)) \quad (4.71)$$

are real because  $L(\pm 1)$  is a real symmetric matrix. This fact plays an important role in the dynamics of the periodic Toda lattice.

The band and gaps of the map  $\Phi$  are precisely the bands and gaps in the spectrum of the associated periodic discrete Schrödinger operator  $L$  on  $\mathbf{Z}$

$$[Lf](i) = e^{q_{i-1}-q_i} f(i-1) + p_i f(i) + e^{q_i-q_{i+1}} f(i+1), \quad i \in \mathbf{Z}.$$

Indeed, by (4.69)  $L$  commutes with translation operator  $T$

$$[Tf](i) = f(i+N)$$

and (4.70) is the restriction of  $L$  onto the  $N$ -dimensional  $w$ -eigenspace of  $T$ . In a band, the Bloch-Floquet multiplier  $w$  is complex number of absolute value 1 and hence  $L$  has a bounded eigenfunction.

It can be shown that all curves of the form (4.51) with  $N$  real ovals arise in this way. This is similar to the result of [47] that the spectral curves of periodically weighted planar dimers parameterize Harnack (also known as maximal) plane curves. Incidentally, they are also M-curves, not just because they are used in the M-theory construction of the gauge theory [7] but also, and mostly<sup>1</sup> because they have exactly real  $N$  ovals.

For example, taking the lattice at rest leads to Chebyshev polynomials. In this case all gaps shrink to points.

#### 4.9. An $SU(3)$ example

Here is an example of a limit shape  $f_\star$ . Take

$$P(z) = z^3 - 4z.$$

To visualize the curve  $w + \frac{1}{w} = P(z)$ , let's look at the plots of  $\Re(w)$  and  $\Im(w)$  for  $z \in [-3, 3]$  plotted in the Fig.8 in bold and normal, respectively

---

<sup>1</sup> We should apologize to M-theorists for the fact, that M-manifolds were introduced long time before the 11d sugra was invented

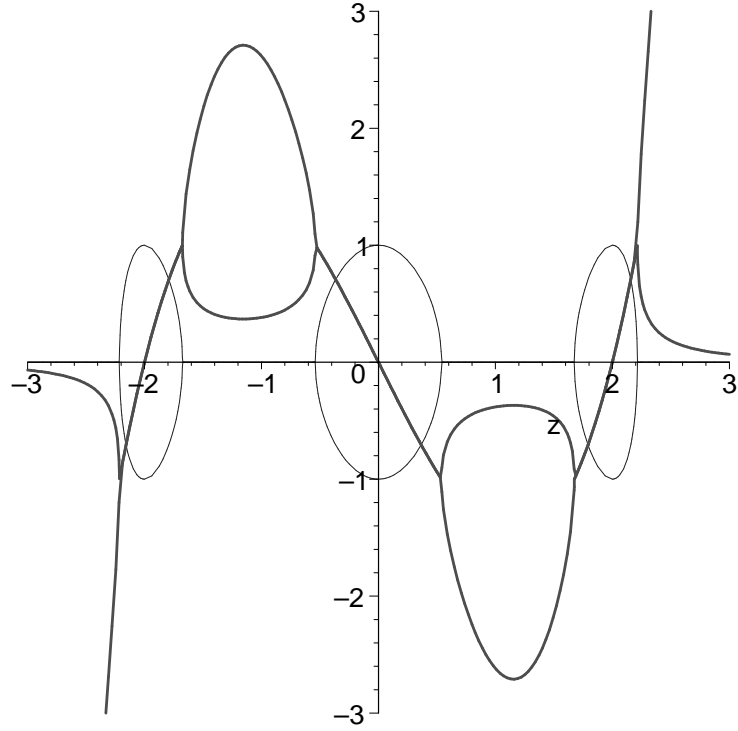

**Fig.9**

The three parts of this curve correspond to the three bands of the corresponding limit shape  $f_*$  plotted in the following figure

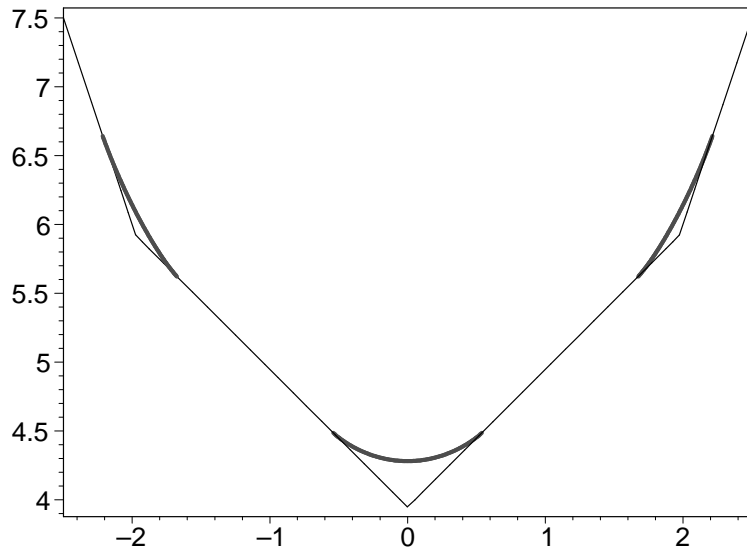

**Fig.10**

#### 4.10. Higher Casimirs

Just as in [10] we could deform the theory by adding arbitrary higher Casimirs to the

microscopic prepotential:

$$\mathcal{F}_{UV} = 2\pi i \left[ \frac{\tau_0}{2} \text{Tr} \Phi^2 + \sum_{\vec{n}} \tau_{\vec{n}} \prod_{J=1}^{\infty} \left( \frac{1}{J} \text{Tr} \Phi^J \right)^{n_J} \right] \quad (4.72)$$

The deformations by the single trace operators are especially simple, as they would lead to the modification of the action  $\mathcal{S}(f)$  by the purely surface term:

$$\mathcal{S}(f; \tau_{\vec{n}}) = -\mathcal{E}_{\Lambda}(f) + \frac{1}{2} \int dx \sigma(f') + \frac{1}{2} \int dx f''(x) \sum_{k=1}^{\infty} \tau_k \frac{x^{k+1}}{k+1} \quad (4.73)$$

Note that  $\tau_1$  shifts  $\log(\Lambda)$ . Presumably the critical point of (4.73) would be a solution of some generalization of Whitham equations [48][40][18][49][50][51].

## 5. DUAL PARTITION FUNCTION AND CHIRAL FERMIONS

In this section we show that a certain transform of the partition function (3.2) has a natural fermionic representation. The physical origin of these fermions is still not completely clear. One way to understand them is to invoke the Chern-Simons/closed string duality of Gopakumar-Vafa [52], and then the fermionic representation of the large  $N$  topological gauge theories [53]. Another possible origin is through the M-theory fivebrane realization of the gauge theory. Mathematically this story is very much related to the Heisenberg algebra representation in the cohomology of the moduli space of the torsion free sheaves on  $\mathbf{CP}^2$ , studied in [54].

### 5.1. Dual partition function

Let  $\xi_1, \dots, \xi_N$  be the complex parameters,

$$\sum_l \xi_l = 0$$

Consider

$$Z^D(\xi; p; \hbar, \Lambda) = \sum_{\substack{p_1, \dots, p_N \in \mathbf{Z}, \\ \sum_l p_l = p}} Z(\hbar(p_l + \rho_l); \hbar, \Lambda) \exp\left(\frac{i}{\hbar} \sum_l p_l \xi_l\right) \quad (5.1)$$

Clearly,

$$Z^D(\xi; p + N; \hbar, \Lambda) = Z^D(\xi; p; \hbar, \Lambda) \quad (5.2)$$

(shift all  $p_l$ 's by 1). Thus, there are essentially  $N$  partition functions one could consider. They are labeled by the level 1 integrable highest weights of  $\widehat{\mathfrak{sl}}_N$ . Moreover:

$$Z^D(\xi; p + 1; \hbar, \Lambda) = Z^D(\xi^+; p; \hbar, \Lambda) \quad (5.3)$$

where

$$\xi^+ = (\xi_2, \xi_3, \dots, \xi_N, \xi_1) \quad (5.4)$$

To extract from  $Z^D$  the partition function of interest we perform a contour integral. In the search for prepotential we are actually interested in the extremely high frequency Fourier modes of  $Z^D$ , as we want  $\mathcal{F}_0(\mathbf{a}; \Lambda)$  as a function of finite  $a_l = \hbar(p_l + \rho_l)$ , with  $\hbar \rightarrow 0$ . This

means that the inverse Fourier transform can be evaluated using the saddle point, which we already analyzed.

Clearly,

$$Z^D(\xi; p; \hbar, \Lambda) = \exp \sum_{g=0}^{\infty} \hbar^{2g-2} \mathcal{F}_g^D(\xi; p, \Lambda) \quad (5.5)$$

where  $\mathcal{F}_0^D$  is in fact  $p$ -independent, and is given by the Legendre transform of  $\mathcal{F}_0$ :

$$\mathcal{F}_0^D(\xi; \Lambda) = i \sum_l \xi_l a_l + \mathcal{F}_0(\mathbf{a}; \Lambda), \quad \xi_l = i \frac{\partial \mathcal{F}_0}{\partial a_l}, \quad (5.6)$$

i.e.  $\xi_l$  must be given by the  $\mathbf{b}_l$  periods of the differential  $dS$ .

**Remark:** Note that in this section  $\xi_l$  differ by the factor  $i$  from the  $\xi_l$ 's of the previous section.

## 5.2. Free fermions

Introduce  $N$  free chiral fermions  $\psi^{(l)}$ :

$$\begin{aligned} \psi^{(l)}(z) &= \sum_{r \in \mathbf{Z} + \frac{1}{2}} \psi_r^{(l)} z^{-r} \left( \frac{dz}{z} \right)^{\frac{1}{2}} \\ \tilde{\psi}^{(l)}(z) &= \sum_{r \in \mathbf{Z} + \frac{1}{2}} \tilde{\psi}_r^{(l)} z^{-r} \left( \frac{dz}{z} \right)^{\frac{1}{2}} \end{aligned} \quad (5.7)$$

$$\{\psi_r^{(l)}, \tilde{\psi}_s^{(m)}\} = \delta_{lm} \delta_{r+s}$$

which can also be packed into a single chiral fermion  $\Psi$

$$\begin{aligned} \Psi_r, \tilde{\Psi}_r, \quad r \in \mathbf{Z} + \frac{1}{2} \\ \{\Psi_r, \tilde{\Psi}_s\} = \delta_{r+s} \end{aligned} \quad (5.8)$$

$$\Psi(z) = \sum_{r \in \mathbf{Z} + \frac{1}{2}} \Psi_r z^{-r} \left( \frac{dz}{z} \right)^{\frac{1}{2}}, \quad \tilde{\Psi}(z) = \sum_{r \in \mathbf{Z} + \frac{1}{2}} \tilde{\Psi}_r z^{-r} \left( \frac{dz}{z} \right)^{\frac{1}{2}}$$

in the standard fashion [55]:

$$\Psi_{N(r+\rho_l)} = \psi_r^{(l)}, \quad \tilde{\Psi}_{N(r-\rho_l)} = \tilde{\psi}_r^{(l)} \quad (5.9)$$



The operators  $\Psi_r, \tilde{\Psi}_s$  act in the standard fermionic Fock space  $\mathcal{H}$  (sometimes called an infinite wedge representation). It splits as a sum of Fock subspaces with fixed  $U(1)$  charge, defined below:

$$\mathcal{H} = \bigoplus_{p \in \mathbf{Z}} \mathcal{H}[p]$$

Introduce affine  $\widehat{U(N)}_1$  currents, which act within  $\mathcal{H}[p]$  for any  $p$ :

$$J^{ln}(z) =: \psi^{(l)} \tilde{\psi}^{(n)} := \sum_{k \in \mathbf{Z}} \frac{dz}{z^{k+1}} \sum_{r \in \mathbf{Z} + \frac{1}{2}} : \psi_r^{(l)} \tilde{\psi}_{k-r}^{(n)} : \quad (5.10)$$

Here we normal order with respect to the vacuum  $|0\rangle$ , which is annihilated by

$$\begin{aligned} \Psi_r |0\rangle &= 0, & r > 0 \\ \tilde{\Psi}_s |0\rangle &= 0, & s > 0 \end{aligned} \quad (5.11)$$

which is equivalent to

$$\begin{aligned} \psi_r^{(l)} |0\rangle &= 0, & r > 0, \\ \tilde{\psi}_s^{(l)} |0\rangle &= 0, & s > 0 \end{aligned} \quad (5.12)$$

The normal ordered product is simply:

$$\begin{aligned} : \Psi_r \tilde{\Psi}_s : &:= \begin{cases} \Psi_r \tilde{\Psi}_s, & s > 0 \\ - \tilde{\Psi}_s \Psi_r, & r > 0 \end{cases} \\ : \psi_r^{(l)} \tilde{\psi}_s^{(m)} : &:= \begin{cases} \psi_r^{(l)} \tilde{\psi}_s^{(m)}, & s > 0 \\ - \tilde{\psi}_s^{(m)} \psi_r^{(l)}, & r > 0 \end{cases} \end{aligned} \quad (5.13)$$

One can also introduce vacua with different overall  $U(1)$  charges:

$$\begin{aligned} \Psi_r |p\rangle &= 0, & r > p, \\ \tilde{\Psi}_s |p\rangle &= 0, & s > -p \\ |p\rangle &\in \mathcal{H}[p] \end{aligned} \quad (5.14)$$

It is also useful to work with  $\Psi$  and the corresponding  $\widehat{U(1)}_1$  currents:

$$\mathcal{J}(z) =: \Psi \tilde{\Psi} : (z) = -\frac{1}{N} \sum_{l,m} J^{lm} (z^{-N}) z^{l-m} \quad (5.15)$$

and Virasoro generators:

$$L_0 = \sum_{r \in \mathbf{Z} + \frac{1}{2}} r : \Psi_r \tilde{\Psi}_{-r} : \quad (5.16)$$

Note:

$$L_0 |p\rangle = \frac{p^2}{2} |p\rangle \quad (5.17)$$

### 5.2.1. Bosonization

It is sometimes convenient to work with the chiral boson:

$$\begin{aligned}
\phi(z) &= q - i\mathcal{J}_0 \log(z) + i \sum_{n \neq 0} \frac{1}{n} \mathcal{J}_n z^{-n} \\
\partial\phi &\equiv z\partial_z\phi = -i\mathcal{J} \\
[q, J_0] &= i \\
\Psi(z) &=: e^{i\phi(z)} : , \quad \tilde{\Psi}(z) =: e^{-i\phi(z)} :
\end{aligned} \tag{5.18}$$

We will also use a truncated boson, with the zero mode  $q$  removed:

$$\varphi(z) = -i\mathcal{J}_0 \log(z) + i \sum_{n \neq 0} \frac{1}{n} \mathcal{J}_n z^{-n} \tag{5.19}$$

The space  $\mathcal{H}[p]$  is actually an irreducible representation of the Heisenberg algebra generated by  $\mathcal{J}$ :

$$\mathcal{H}[p] = \text{Span}_{n_1, \dots, n_k > 0} \mathcal{J}_{-n_1} \dots \mathcal{J}_{-n_k} |p\rangle, \quad \mathcal{J}_0 \Big|_{\mathcal{H}[p]} = p \tag{5.20}$$

We also recall:

$$\Psi : \mathcal{H}[p] \rightarrow \mathcal{H}[p+1], \quad \tilde{\Psi} : \mathcal{H}[p] \rightarrow \mathcal{H}[p-1] \tag{5.21}$$

### 5.3. Dual partition function as a current correlator

We claim:

$$Z^D(\xi; p; \hbar, \Lambda) = \langle p | e^{\frac{1}{\hbar} \oint \text{Tr} E_+(z) J(z)} e^{\frac{1}{\hbar} \oint \text{Tr} H(z) J(z)} \Lambda^{2L_0} e^{-\frac{1}{\hbar} \oint \text{Tr} E_-(z) J(z)} |p\rangle \tag{5.22}$$

where the matrices  $E_{\pm}, H$  are given by:

$$\begin{aligned}
E_+(z) &= zE^{N,1} + \sum_{l=2}^N E^{l-1,l}, \\
H(z) &= \sum_l \xi_l E^{l,l} \\
E_-(z) &= z^{-1}E^{1,N} + \sum_{l=2}^N E^{l,l-1}
\end{aligned} \tag{5.23}$$

#### 5.4. Affine algebras and arbitrary gauge groups

Note that (5.22) can be written using the Chevalley generators  $e_i, f_i, h_i$  of the affine Lie algebra  $\widehat{\mathfrak{sl}}_N$ :

$$Z^D(\xi; p; \hbar, \Lambda) = (u_{\hbar}, \Lambda^{2h_0} e^{\mathbf{H}_{\xi}} u_{\hbar})_{V_{\omega_p}},$$

$$u_{\hbar} = \exp\left(\frac{N}{\hbar} \sum_{l=1}^N f_{l-1}\right) v_0 \quad (5.24)$$

$$\mathbf{H}_{\xi} = \frac{1}{\hbar} \sum_{l=1}^{N-1} (\xi_l - \xi_{l+1}) h_l$$

where  $V_{\omega_p}$  is the integrable highest weight module with the highest weight vector  $v_0$  (annihilated by the simple roots  $e_l$ ) and the highest weight  $\omega_p$ ,  $p = 1, \dots, N$ .

The formula (5.24) has an obvious generalization to any simple Lie algebra  $\widehat{\mathfrak{g}}$ . Conjecturally, it gives the partition function in the  $\Omega$ -background in the  $\mathcal{N} = 2$  gauge theory with the gauge group,  $S$ -dual to  $G$  (Langlands dual).

#### 5.5. Dual partition function and $\mathfrak{gl}(\infty)$

We now return to the  $A_{N-1}$  case.

In the language of the single fermion  $\Psi$  the formula (5.22) reads as:

$$Z^D(\xi; p; \hbar, \Lambda) = \langle p | e^{\frac{\sigma_1}{\hbar}} e^{\mathbf{H}_{\xi}} \Lambda^{2L_0} e^{\frac{\sigma_{-1}}{\hbar}} | p \rangle \quad (5.25)$$

where  $\mathbf{H}_{\xi}$  is a diagonal matrix:

$$\mathbf{H}_{\xi} = \frac{1}{\hbar} \sum_r \xi_{(r+\frac{1}{2}) \bmod N} : \Psi_r \tilde{\Psi}_{-r} :$$

Clearly,  $[\mathbf{H}_{\xi}, L_0] = 0$ . The formula (5.25) expresses the dual partition function as an average with the Plancherel measure of the  $N$ -periodic weight  $e^{\mathbf{H}_{\xi}}$ .

**Remark:** *On Toda equation*

The function  $Z^D$  obeys Toda equation (cf. [56]):

$$4\partial_{\log(\Lambda)}^2 \log(Z^D(p)) = \frac{Z^D(p+1)Z^D(p-1)}{(Z^D(p))^2} \quad (5.26)$$

In fact, the formula (5.25) identifies  $Z^D$  as the tau-function of the Toda lattice hierarchy, thanks to the results of [57][36][58], with the specific parameterization of the times. We hope to return to this property of the partition function in a future publication.

## 5.6. The $U(1)$ case

In order to understand (5.25)(5.22) we consider first the case  $N = 1$ . As the Plancherel measure is  $a$ -independent in this case, we can study both the partition function and its dual at ease. Let us represent the states in the fermionic Fock space as semi-infinite functions of  $\Psi_r$ . The charge  $p$  vacuum  $|p\rangle$  in this representation corresponds to the product:

$$|p\rangle = \overrightarrow{\prod}_{r>-p} \Psi_r \equiv \Psi_{-p+\frac{1}{2}} \Psi_{-p+\frac{3}{2}} \cdots \quad (5.27)$$

To every partition  $\mathbf{k}$  there corresponds the so-called *charge  $p$  partition state*:

$$\begin{aligned} |p; \mathbf{k}\rangle &= \overrightarrow{\prod}_{i=1,2,\dots} \Psi_{-p-\frac{1}{2}+i-k_i} = \overrightarrow{\prod}_{1 \leq i \leq n} \Psi_{-p-\frac{1}{2}+i-k_i} \overleftarrow{\prod}_{1 \leq i \leq n} \tilde{\Psi}_{p+\frac{1}{2}-i} |p\rangle = \\ &\overrightarrow{\prod}_{1 \leq i \leq n} \Psi_{-p-\frac{1}{2}+i-k_i} |p-n\rangle \end{aligned} \quad (5.28)$$

These states form a complete basis in the space  $\mathcal{H}[p]$ . The important fact, responsible for (5.25), is the variant of the boson-fermion correspondence:

$$\exp \frac{1}{\hbar} \mathcal{J}_{-1} |p\rangle = \sum_{\mathbf{k}} \frac{\mu(\mathbf{k})}{\hbar^{|\mathbf{k}|}} |p; \mathbf{k}\rangle \quad (5.29)$$

where factor  $\mu(\mathbf{k})$  is the Plancherel measure (3.12). It follows:

$$Z(a, \hbar, \Lambda) = \Lambda^{\frac{a^2}{\hbar^2}} \langle 0 | e^{-\frac{1}{\hbar} \mathcal{J}_1} \Lambda^{2L_0} e^{\frac{1}{\hbar} \mathcal{J}_{-1}} | 0 \rangle \quad (5.30)$$

which for  $a = \hbar p$  can also be written as

$$Z(a, \hbar, \Lambda) = \langle p | e^{-\frac{1}{\hbar} \mathcal{J}_1} \Lambda^{2L_0} e^{\frac{1}{\hbar} \mathcal{J}_{-1}} | p \rangle \quad (5.31)$$

•

To make use of (5.29) we *blend*  $N$  partitions  $\mathbf{k}_l$ ,  $l = 1, \dots, N$  into a single one,  $\mathbf{K}$ . Let  $p_1, \dots, p_N$  be some integers. Consider the following countable set of distinct integers:

$$\{N(p_l + k_{li} - i) + l - 1 \mid l = 1, \dots, N, \quad i \in \mathbf{N}\} = \{p + K_I - I \mid I \in \mathbf{N}\} \quad (5.32)$$

where the sequence  $K_1 \geq K_2 \geq \dots$  is defined by (5.32) and the condition that it stabilizes to zero. Likewise,  $p$  is determined from (5.32) and depends only on  $p_l$ 's:

$$p = \sum_l p_l \quad (5.33)$$

Let

$$a_l = \hbar (p_l + \rho_l) .$$

The size of the blended partition  $\mathbf{K}$  is expressed in terms of  $a_l$ 's (see appendix **A**):

$$|\mathbf{K}| = \frac{1 - N^2}{24} - \frac{p^2}{2} + N \sum_l \frac{\tilde{a}_l^2}{2\hbar^2} + N \sum_{l,i} k_{li} \quad (5.34)$$

It is now straightforward to evaluate  $\mu_{\vec{\mathbf{k}}} := \mu(\mathbf{K})$ :

$$\mu_{\mathbf{K}}^2 = Z_{\vec{\mathbf{k}}}(a; \hbar), \quad (5.35)$$

and arrive at (5.25).

## 6. $\mathcal{N} = 2$ THEORY WITH ADJOINT HYPERMULTIPLY

In a sense the most interesting  $\mathcal{N} = 2$  theory is the theory with the massive hypermultiplet in the adjoint representation. This theory is ultraviolet finite, and is thus characterized by the microscopic coupling  $\tau_0 = \frac{\vartheta_0}{2\pi} + \frac{4\pi i}{g_0^2}$ , and by the mass  $\mathbf{m}$  of the hypermultiplet. It is convenient to use the nodal parameter  $q = e^{2\pi i \tau_0}$  to count instantons.

In this case the prepotential of the low-energy effective theory is expected to have the following expansion:

$$\begin{aligned} \mathcal{F}_0(\mathbf{a}, \mathbf{m}, q) = & \pi i \tau_0 \sum_l a_l^2 - \\ & - \frac{1}{2} \sum_{l \neq n} [(a_l - a_n)^2 \log(a_l - a_n) - (a_l - a_n + \mathbf{m})^2 \log(a_l - a_n + \mathbf{m})] + \\ & + \sum_{k=1}^{\infty} q^k f_k(\mathbf{a}, \mathbf{m}) \end{aligned} \quad (6.1)$$

The previous calculations of the coefficients  $f_k$  for low values of  $k$  were done in [59]. One of the remarkable features of the prepotential of the low-energy effective theory of the theory with adjoint hypermultiplet is its relation to the elliptic Calogero-Moser system [60]. Indeed, in [20] an ansatz for the family of curves encoding the prepotential was proposed, using a version of Hitchin system [61]. This very construction of the elliptic Calogero-Moser system was found earlier [62]. One of the advantages of this realization is its simple extension to the Lie groups other than  $SU(N)$  (see, e.g. [63]). The coefficients  $f_k$  of the prepotential of the Calogero-Moser system were calculated for  $k = 1, 2$  in, e.g. [41].

### 6.1. Partition function

The partition function of the theory with adjoint hypermultiplet in the  $\Omega$ -background is explicitly calculable (in [9] the contour integral representation was given, the poles of the integral are exactly the same as those of the contour integral for the pure theory) and the answer is ( $\mu = \mathbf{m}/\hbar$ ):

$$\begin{aligned} Z(\mathbf{a}, \mathbf{m}; \hbar, q) = & \exp \sum_{g=0}^{\infty} \hbar^{2g-2} \mathcal{F}_g(\mathbf{a}, \mathbf{m}; q) \\ = & q^{\frac{1}{2\hbar^2} \sum_l a_l^2 - \frac{1}{24} N(\mu^2 - 1)} \sum_{\vec{\mathbf{k}}} q^{|\vec{\mathbf{k}}|} Z_{\vec{\mathbf{k}}}(\mathbf{a}, \mathbf{m}; \hbar, q) \end{aligned} \quad (6.2)$$

where

$$\begin{aligned}
Z_{\bar{\mathbf{k}}}(\mathbf{a}, \mathbf{m}; \hbar, q) &= Z^{pert}(\mathbf{a}, \mathbf{m}; \hbar, q) \mu_{\bar{\mathbf{k}}}^2(\mathbf{a}, \hbar) \times \\
&\prod_{(l,i) \neq (n,j)} \frac{(a_l - a_n + \mathbf{m} + \hbar(j-i))}{(a_l - a_n + \mathbf{m} + \hbar(k_{l,i} - k_{n,j} + j - i))} \\
Z^{pert}(\mathbf{a}, \mathbf{m}; \hbar, q) &= \exp \sum_{l,n} \gamma_{\hbar}(a_l - a_n; q) - \gamma_{\hbar}(a_l - a_n + \mathbf{m}; q)
\end{aligned} \tag{6.3}$$

## 6.2. Abelian theory

Let us consider  $N = 1$  case first. Let  $\mu = \frac{\mathbf{m}}{\hbar}$ . In the  $N = 1$  case we are to sum over all partitions  $\mathbf{k}$ :

$$Z(a, \mathbf{m}; \hbar, q) = q^{\frac{a^2}{2\hbar^2} + \frac{1}{24}(\mu^2 - 1)} e^{-\gamma_{\hbar}(\mathbf{m}; q)} \sum_{\mathbf{k}} q^{|\mathbf{k}|} \prod_{\square \in \mathbf{k}} \left( \frac{h(\square)^2 - \mu^2}{h(\square)^2} \right) \tag{6.4}$$

The fact that (6.2) reduces to (6.4) for  $N = 1$  is a consequence of a simple identity between the Chern characters:

$$\sum_{i < j} e^{\hbar(k_i - k_j + j - i)} - e^{\hbar(j - i)} - e^{\mathbf{m} + \hbar(k_i - k_j + j - i)} + e^{\mathbf{m} + \hbar(j - i)} = \sum_{\square \in \mathbf{k}} e^{\mathbf{m} + \hbar h(\square)} - e^{\hbar h(\square)} \tag{6.5}$$

Another expression for (6.4) will be useful immediately:

$$\begin{aligned}
Z(a, \mathbf{m}; \hbar, q) &= q^{\frac{a^2}{2\hbar^2}} e^{-\gamma_{\hbar}(\mathbf{m}; q)} \mathcal{Z}(\mu), \quad \mathcal{Z}(\mu) = q^{\frac{1}{24}(\mu^2 - 1)} \sum_{\mathbf{k}} q^{|\mathbf{k}|} \mathcal{Z}_{\mathbf{k}}(\mu) \\
\mathcal{Z}_{\mathbf{k}}(\mu) &= \prod_{i=1}^{\ell(\mathbf{k})} \frac{(\ell(\mathbf{k}) + k_i - i + \mu)! (\ell(\mathbf{k}) + k_i - i - \mu)! (\ell(\mathbf{k}) - i)!^2}{(\ell(\mathbf{k}) - i + \mu)! (\ell(\mathbf{k}) - i - \mu)! (\ell(\mathbf{k}) + k_i - i)!^2} \times \\
&\quad \times \frac{\det_{1 \leq i, j \leq \ell(\mathbf{k})} \left\| \frac{1}{k_i - k_j + j - i + \mu} \right\|}{\det_{1 \leq i, j \leq \ell(\mathbf{k})} \left\| \frac{1}{j - i + \mu} \right\|}
\end{aligned} \tag{6.6}$$

**Proposition 4** The analogue of the formula (5.31) for the theory with adjoint matter is:

$$\mathcal{Z}(\mu) = q^{\frac{\mu^2}{24}} \text{Tr}_{\mathcal{H}_0} q^{L_0 - \frac{1}{24}} \mathcal{V}_{\mu}(1) \tag{6.7}$$

where

$$\mathcal{V}_{\mu}(z) = : e^{i\mu\varphi(z)} : = \exp \left( -\mu \sum_{n>0} \mathcal{J}_{-n} \frac{z^n}{n} \right) z^{\mu\mathcal{J}_0} \exp \left( \mu \sum_{n>0} \mathcal{J}_n \frac{z^{-n}}{n} \right) \tag{6.8}$$

$\varphi(z)$  is the bosonic field (5.19), and  $\mathcal{H}_{\lambda}$  is the charge  $\lambda$  subspace of the fermionic Fock space.

**Proof:**

We represent the trace (6.7) as a sum over partition states:  $|p; \mathbf{k}\rangle$ , where  $p = \frac{\alpha}{\hbar}$  is fixed. We start by evaluating:

$$\langle \mathbf{k} | \mathcal{V}_\mu(1) | \mathbf{k} \rangle = \frac{\det_{1 \leq i, j \leq \ell(\mathbf{k})} \| G_{k_i - i + \ell(\mathbf{k}), k_j - j + \ell(\mathbf{k})} \|}{\det_{1 \leq i, j \leq \ell(\mathbf{k})} \| G_{-i + \ell(\mathbf{k}), -j + \ell(\mathbf{k})} \|} \quad (6.9)$$

where we employ Wick's theorem, and where for  $i, j \in \mathbf{Z}_+$ :

$$\begin{aligned} G_{ij} &= (-)^{i-j} \frac{(i+\mu)!(j-\mu)!}{i!j!(i-j+\mu)!} \frac{\sin \pi \mu}{\pi \mu} \\ &= \text{Coeff}_{x^i y^j} \left( \frac{1-y}{1-x} \right)^\mu \frac{1}{1-xy} = \\ &= \langle 0 | \tilde{\Psi}_{j+\frac{1}{2}} \mathcal{V}_\mu(1) \Psi_{-\frac{1}{2}-i} | 0 \rangle \end{aligned} \quad (6.10)$$

The second line of (6.10) follows from:

$$[\mu - y\partial_y + x\partial_x] \left\{ \left( \frac{1-y}{1-x} \right)^\mu \frac{1}{1-xy} \right\} = \mu(1-y)^{\mu-1}(1-x)^{-\mu-1}$$

while the last line is most easily derived from the current action on the fundamental fermions  $\Psi, \tilde{\Psi}$ :

$$\begin{aligned} \langle 0 | \tilde{\Psi}(y^{-1}) \mathcal{V}_\mu(1) \Psi(x) | 0 \rangle &= \\ &= \exp \left( \mu \sum_{n>0} \frac{1}{n} (x^n - y^n) \right) \times \langle 0 | \tilde{\Psi}(y^{-1}) \Psi(x) | 0 \rangle = \\ &= \left( \frac{1-y}{1-x} \right)^\mu \frac{(dx)^{\frac{1}{2}} (dy)^{\frac{1}{2}}}{1-xy} \end{aligned} \quad (6.11)$$

from which (6.10) follows by employing the expansion (5.8).

QED

**Remark:** Note that an immediate consequence of the equalities (6.4) and (6.7) is following identity

$$\prod_{n>0} (1 - q^n)^{\mu^2 - 1} = \sum_{\mathbf{k}} q^{|\mathbf{k}|} \prod_{\square \in \mathbf{k}} \frac{h(\square)^2 - \mu^2}{h(\square)^2} \quad (6.12)$$

$$\mathcal{Z}(\mu) = \eta(q)^{\mu^2 - 1}$$

(see appendix C for notations) which interpolates between the Dyson-Macdonald formulas for the root systems  $A_n$ . Indeed, when  $\mu = n$ , the exponent on the left in (6.12) equals

$$\dim SU(\mu) = \mu^2 - 1,$$



while on the right we have a sum over all partitions with no hooks of length  $\mu$ , which one can easily identify with the sum over the weight lattice of  $SU(n)$  entering the Dyson-Macdonald formula.

### 6.2.1. Higher Casimirs and Gromov-Witten theory of elliptic curve

Just as in [10] we can consider deforming the theory by the higher Casimirs. Just as in [10] these are represented in the free fermion formalism by the  $\mathcal{W}$ -generators, and the trace (6.7) becomes the  $W_{1+\infty}$  character, in the presence of the “vertex” operator  $\mathcal{V}_{\frac{\mathbf{m}}{\hbar}}$ .

For  $\mathbf{m} = 0$  this trace becomes *exactly* the  $W_{1+\infty}$  character, as studied in [64][65]. As shown in [36] this trace also coincides with the all-genus partition function of the Gromov-Witten theory of an elliptic curve (see also [66]). It would be nice to find a Gromov-Witten dual of the “vertex” operator  $\mathcal{V}_\mu$ , and establish precise relation of (6.12) to [36][65][64].

Note that the “flow to the pure  $\mathcal{N} = 2$  theory” which is represented by the limit  $\mathbf{m} \rightarrow \infty$ ,  $q \rightarrow 0$ , s.t.  $\Lambda^2 = \mathbf{m}^2 q$  stays finite, leads to the dual Gromov-Witten theory of  $\mathbf{CP}^1$  with  $\log(\Lambda^2)$  playing the rôle of the Kähler class.

### 6.3. Nonabelian case

Using (6.4) it is simple to express the partition function (6.2) in terms of free fermions:

$$Z(\mathbf{a}; \hbar, \mathbf{m}, q) = \text{Tr}_{\mathcal{H}_{\frac{\mathbf{a}}{\hbar}}^{(N)}} (q^{L_0} \mathcal{V}_\mu(1)) \quad (6.13)$$

where

$$\mathcal{H}_{\mathbf{p}}^{(N)} = \otimes_{l=1}^N \mathcal{H}[\mathbf{p}_l]$$

stands for the Fock space of  $N$  free fermions, with specified charges  $(\mathbf{p}_1, \dots, \mathbf{p}_N)$  ( $U(1)^N$  weight, in the language of affine Lie algebras).

We also have an expression for the dual partition function:

$$Z^D(\xi, p; \hbar, \mathbf{m}, q) = \text{Tr}_{\mathcal{H}_p} (q^{L_0} \mathcal{V}_\mu(1) e^{\mathbf{H}_\xi}) \quad (6.14)$$

Of course, the modular properties of the partition functions (6.6)(6.12)(6.14) reflect the S-duality of the  $\mathcal{N} = 4$  theory [11].

## 6.4. Path representation

As in the pure gauge theory case it is extremely useful to represent the partition function as a sum over the profiles – paths  $f(x)$ . The result is:

$$\begin{aligned}
 Z(\mathbf{a}, \mathbf{m}; \hbar, q) &= \sum_{f \in \Gamma_{\mathbf{a}}^{discrete}} Z_f(\mathbf{a}, \mathbf{m}; \hbar, q) \\
 Z_f(\mathbf{a}, \mathbf{m}; \hbar, q) &= \exp \left( -\frac{1}{4} \int dx dy f''(x) f''(y) \gamma_{\hbar}(x-y; q) + \right. \\
 &\quad \left. + \frac{1}{4} \int dx dy f''(x) f''(y) \gamma_{\hbar}(x-y + \mathbf{m}; q) + \right. \\
 &\quad \left. + \frac{1}{4\hbar^2} \log(q) \int dx x^2 f''(x) \right)
 \end{aligned} \tag{6.15}$$

Interchanging  $x$  and  $y$  one sees that this is symmetric with respect to  $\mathbf{m} \mapsto -\mathbf{m}$ .

## 6.5. Variational problem for the prepotential

Again, just as in the case of the pure  $\mathcal{N} = 2$  gauge theory we are looking for the extremum of a certain action functional on the space  $\Gamma_{\mathbf{a}}$  of profiles  $f(x)$  with fixed partial charges. By adding the surface tension term to the action we get a minimization problem on the space of all profiles, i.e. functions that satisfy

$$f(x) - N|x| = 0, \quad |x| \gg 0,$$

and the Lipschitz condition  $|f'(x)| \leq N$ . The Lipschitz condition in our case will be satisfied automatically, since all extrema will be convex. We also impose the total zero charge condition,  $a = 0$ , i.e.

$$\int_{\mathbf{R}} x f''(x) dx = 0 \tag{6.16}$$

In this section we set  $\mathbf{m} = im$ .

### 6.5.1. Path energy and surface tension

Let

$$L(x) = \frac{1}{2} x \log \left( \frac{x^2}{x^2 + m} \right) - m \arctan \frac{x}{m} \tag{6.17}$$

We have:

$$\begin{aligned} L'(x) &= \frac{1}{2} \log \left( \frac{x^2}{x^2 + m^2} \right), \\ L''(x) &= \frac{1}{x} - \frac{1}{2} \left( \frac{1}{x + im} + \frac{1}{x - im} \right). \end{aligned} \tag{6.18}$$

•

We introduce a generalization of the energy functional (4.28):

$$\begin{aligned} \mathcal{E}_{q,m}(f) &= -\frac{1}{2} \int_{x < y} (N + f'(x))(N - f'(y)) L'(y - x) dx dy + \\ &\quad - \frac{i\pi\tau}{2} \int_{\mathbf{R}} x^2 f''(x) dx \end{aligned} \tag{6.19}$$

where the first term is the leading  $\hbar \rightarrow 0$  asymptotics of (6.15), and the second term comes from the weight  $q^{|\vec{k}|}$ . In the limit  $q \rightarrow 0, m \rightarrow \infty$ , so that  $\Lambda = mq^{\frac{1}{2N}}$  stays finite,  $\mathcal{E}_{q,m} \rightarrow \mathcal{E}_\Lambda$  (this reflects the flow of the theory with adjoint hypermultiplet to the pure  $\mathcal{N} = 2$  super-Yang-Mills theory).

•

The functional which we want to maximize is:

$$\mathcal{S}_{q,m}(f) = -\mathcal{E}_{q,m}(f) + \frac{1}{2} \int \sigma(f'(x)) dx, \tag{6.20}$$

where the last term is the usual surface tension term. Again, the functional (6.20) is convex, therefore every local maximizer is also a global maximizer.

### 6.5.2. Variational equations

Varying  $f'(x)$  in (6.20), and integrating by parts, we obtain the following equation

$$\int_{y \neq x} f''(y) L(y - x) dy - \sigma'(f'(x)) + 2\pi i \tau x = \text{const} \tag{6.21}$$

which should be satisfied at any point of continuity of  $\sigma'(f'(x))$ . The constant in (6.21) is the Lagrange multiplier corresponding to the constraint (6.16). At the points of discontinuity of  $\sigma'(f'(x))$ , the equality (6.21) should be replaced by the corresponding two-sided inequalities.

The function  $\sigma'$  is piecewise constant, therefore differentiating (6.21) with respect to  $x$  we get the equation

$$\int f''(y) L'(y - x) dy = 2\pi i \tau. \tag{6.22}$$

## 6.6. The spectral curve

The facets of the limit shape correspond to the singularities of the surface tension  $\sigma$ , therefore the maximizer  $f$  will have  $N - 1$  of them. This means that the support of  $f''$  will be  $N$  intervals (bands):

$$\text{supp } f'' = \bigcup_{l=1, \dots, N} \text{supp } f_l'' \quad (6.23)$$

and, as in (4.57), we denote:

$$\text{supp } f_l'' = [\alpha_l^-, \alpha_l^+] \quad (6.24)$$

Consider the resolvent  $R(z) \equiv R_f(z; 0, 0)$  introduced in (4.20). It has jump discontinuities along the bands with the jump equal to  $\pi i f''(x)$ . Set, by definition (cf. [67][68]),

$$G(z) = R\left(z - \frac{im}{2}\right) - R\left(z + \frac{im}{2}\right).$$

This function is analytic in the domain  $U$  which is the Riemann sphere with  $2N$  symmetric cuts

$$U = \overline{\mathbf{C}} \setminus \bigcup_{l=1}^N \left[ \alpha_l^- \pm \frac{im}{2}, \alpha_l^+ \pm \frac{im}{2} \right].$$

We have

$$G(z) = O(z^{-2}), \quad z \rightarrow \infty,$$

and hence we can consider the multivalued function

$$\int_{\infty}^z G(y) dy.$$

The period of  $\int G(y) dy$  around any cut is equal to the integral of the jump of  $G(z)$  along the cut. By construction, the jump of  $G(z)$  is  $\pm \pi i f''(x)$  and, as  $\int_{\alpha_l^-}^{\alpha_l^+} f''(y) dy = 2$  we have the well-defined function

$$\begin{aligned} F(z) &= \frac{1}{2\pi i} \int_{\infty}^z G(y) dy \text{ mod } \mathbf{Z} \\ &= \frac{1}{4\pi i} \int_{\mathbf{R}} dy f''(y) \log \left( \frac{z - \frac{im}{2} - y}{z + \frac{im}{2} - y} \right) \text{ mod } \mathbf{Z} \end{aligned} \quad (6.25)$$

We will show that  $F$  is an  $N$ -fold branched cover of the standard cylinder

$$C_{\tau} = \{\varpi \mid |\Im(\varpi)| < -i\tau/2\} \text{ mod } \mathbf{Z}$$

by the domain  $U$ . Clearly,  $F$  maps the infinity of  $U$  to the origin  $\varpi = 0$  of  $C_\tau$ .

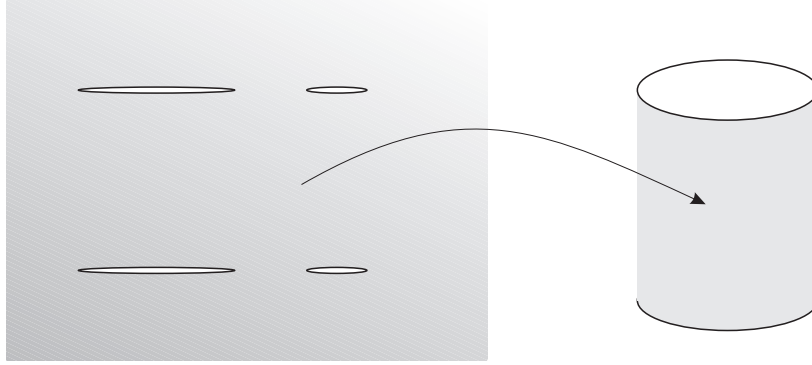

**Fig.11** Covering finite cylinder

The following proposition describes the behavior of the function  $F(z)$  on the both sides of the two cuts corresponding to any band  $[\alpha_l^-, \alpha_l^+]$

**Proposition 5** For any  $x \in [\alpha_l^-, \alpha_l^+]$ , we have

$$F\left(x + \frac{im}{2} \pm i0\right) - F\left(x - \frac{im}{2} \mp i0\right) = \tau. \quad (6.26)$$

**Proof:**

This is, in fact, a reformulation of (6.22). Indeed, let  $x_\pm$  denote the two arguments of  $F$  in (6.26). We need to show that

$$\begin{aligned} \tau &= \int_{x_-}^{x_+} G(y) dy = \\ &= \frac{1}{4\pi i} \int_{x_-}^{x_+} dz \int_{\mathbf{R}} \left( \frac{1}{y - z + \frac{im}{2}} - \frac{1}{y - z - \frac{im}{2}} \right) f''(y) dy. \end{aligned} \quad (6.27)$$

Since the integrand is nonsingular on the domain of integration, we can change the order of integration, which gives

$$\frac{1}{2\pi i} \int L'(y - x) f''(y) dy = \tau, \quad (6.28)$$

which is precisely (6.22).

QED

Since  $f''(x)$  is real, we have

$$R(\bar{z}) = \overline{R(z)},$$

from which it follows that

$$G(\bar{z}) = -\overline{G(z)}, \quad F(\bar{z}) = \overline{F(z)}. \quad (6.29)$$

Proposition (6.26) now implies that

$$\Im F \left( x \pm \frac{im}{2} \right) = \mp i\tau/2, \quad x \in [\alpha_l^-, \alpha_l^+].$$

which means that  $F$  maps the boundary  $\partial U$  to the boundary  $\partial C_\tau$ . It follows that  $F$  maps  $U$  onto  $C_\tau$  and, moreover, since  $F$  has degree  $N$  on the boundary, the map

$$F : U \rightarrow C_\tau$$

is an  $N$ -fold branched cover.

•

Proposition (6.26) also gives the analytic continuation of the function  $F(x)$  across the cuts of  $U$ . The Riemann surface  $\mathcal{C}$  of the function  $F$  is obtained by taking countably many copies of the domain  $U$  and identifying the point

$$x + \frac{im}{2} \pm i0, \quad x \in [\alpha_l^-, \alpha_l^+]$$

on one sheet with the point

$$x - \frac{im}{2} \mp i0$$

on the next sheet.

By construction,  $F$  extends to the map from  $\mathcal{C}$  to the infinite cylinder

$$F : \mathcal{C} \rightarrow \mathbf{C} \bmod \mathbf{Z}$$

satisfying the property

$$F^{-1}(\varpi + \tau) = F^{-1}(\varpi) + im. \quad (6.30)$$

More geometrically this means that the curve  $\mathcal{C}$  is imbedded into the total space  $\mathcal{A}$  of affine bundle over the elliptic curve  $E_\tau = \mathbf{C}/\mathbf{Z} \oplus \tau\mathbf{Z}$  which is obtained from  $C_\tau$  by identifying its boundaries:

$$\mathcal{C} \subset \mathcal{A} = \{(z, \varpi) | z \in \mathbf{C}, \varpi \in \mathbf{C}\} / (z, \varpi) \sim (z, \varpi + 1) \sim (z + \mathbf{m}, \varpi + \tau) \quad (6.31)$$

The map  $F$  is the restriction on  $\mathcal{C}$  of the projection  $\mathcal{A} \rightarrow E_\tau$ . The coordinate  $z$  is the coordinate on the fiber of  $\mathcal{A}$ .

This implies, in turn, that  $\mathcal{C}$  is the spectral curve of the elliptic Calogero-Moser system [60]. Indeed, the latter is the spectral curve of the Lax operator (see appendix C):

$$\begin{aligned} \mathcal{C} : \quad & \text{Det}_{l,n}(L(\varpi) - z) = 0 \\ & L_{ln}(\varpi) = \delta_{ln} \left( p_n + \mathbf{m} \frac{1}{2\pi i} \log(\theta_{11}(\varpi))' \right) + \frac{\mathbf{m}}{2\pi i} (1 - \delta_{ln}) \frac{\theta_{11}(\varpi + q_l - q_n) \theta'_{11}(0)}{\theta_{11}(\varpi) \theta_{11}(q_l - q_n)} \end{aligned} \quad (6.32)$$

and is naturally viewed as the holomorphic curve in  $\mathcal{A}$  representing the homology class of  $N[E_\tau]$  under the identification  $\mathcal{A} \approx \mathbf{C} \times E_\tau$ :  $(z, \varpi) = (p + \mathbf{m} \log(\theta_{11}(\varpi))', \varpi)$ . This condition, together with the behaviour near  $\varpi = 0$  fixes uniquely the  $N$ -parametric family of curves  $\mathcal{C}$ . The coordinates  $u = (u_1, \dots, u_N)$  on the base of the family of curves can be defined using the characteristic polynomial of the Lax operator (6.32). An alternative set of (local) coordinates is given by the so-called action variables, which can be defined as a set of periods of the complexified Liouville one-differential  $z d\varpi$  on  $\mathcal{C}$ . In our construction these periods are linear combinations of  $a_l$ 's,  $\xi_l$ 's and  $m$ , see below.

**Remark:** For  $N = 1$ , the function  $F^{-1}(\varpi)$  is, up to normalization, the classical Weierstraß function  $\zeta(\varpi)$ .

The limit shape  $f$  is reconstructed from the fact that  $f'(x) \bmod 2\mathbf{Z}$  is equal to the jump of the function  $F(x)$  across the cut of  $U$ .

### 6.6.1. Periods

We shall now study the periods of the differential

$$dS = z d\varpi|_{\mathcal{C}} = z dF(z) = \frac{1}{2\pi i} z \left( R \left( z - \frac{im}{2} \right) - R \left( z + \frac{im}{2} \right) \right) dz \quad (6.33)$$

on the Riemann surface  $\mathcal{C}$ .

For  $l = 1, \dots, N$  let  $\mathbf{a}_l^\pm$  denote the 1-cycle, which circles around the cut  $[\alpha_l^- \pm \frac{im}{2}, \alpha_l^+ \pm \frac{im}{2}]$ .

Clearly:

$$\oint_{\mathbf{a}_l^\pm} dS = a_l \pm \frac{im}{2} \quad (6.34)$$

For  $l = 1, \dots, N - 1$ , let  $\beta_l$  be the cycle on  $\mathcal{C}$  joining some points  $x + \frac{im}{2}$  and  $y + \frac{im}{2}$ , where

$$x \in (\alpha_l^-, \alpha_l^+) , \quad y \in (\alpha_{l+1}^-, \alpha_{l+1}^+) ,$$

above both cuts on some sheet of  $\mathcal{C}$  and below both cuts on the next sheet of  $\mathcal{C}$ .

By construction of  $\mathcal{C}$ , we have

$$\begin{aligned} \oint_{\beta_l} z dF(z) &= \int_{x+\frac{im}{2}+i0}^{y+\frac{im}{2}+i0} z dF(z) + \int_{y-\frac{im}{2}-i0}^{x-\frac{im}{2}-i0} z dF(z) = \\ &= \int_{y-\frac{im}{2}-i0}^{y+\frac{im}{2}+i0} z dF(z) - \int_{x-\frac{im}{2}-i0}^{x+\frac{im}{2}+i0} z dF(z). \end{aligned}$$

By the same principle as in the proof of Proposition (6.26), we obtain

$$\begin{aligned} \int_{x-\frac{im}{2}-i0}^{x+\frac{im}{2}+i0} z dF(z) &= \frac{1}{4\pi i} \int_{\mathbf{R}} f''(t) dt \times \\ &= \left[ \left( t + \frac{im}{2} \right) \log \left( \frac{x-t+i0}{x-t-im} \right) + \left( t - \frac{im}{2} \right) \log \left( \frac{x-t-i0}{x-t+im} \right) \right] = \\ &= \frac{1}{2\pi i} \int_{\mathbf{R}} (xL'(t-x) + L(t-x)) f''(t) dt \\ &= \frac{1}{2\pi i} \xi_{l+1} + \text{const} \end{aligned} \tag{6.35}$$

thanks to (6.21)(6.28) and the fact that  $\sigma'(f'(x)) = \xi_l$  because  $x$  lies on the  $l$ 'th band. We summarize:

$$\begin{aligned} \xi_l - \xi_{l+1} &= 2\pi i \oint_{\beta_l} dS \\ a_l \pm \frac{im}{2} &= \oint_{\mathbf{a}_l^\pm} dS \\ \mathcal{F}(\mathbf{a}, \mathbf{m}, q) &= -\mathcal{E}_{q, \mathbf{m}}(f_\star) \end{aligned}$$

(6.36)



## 7. ON ANOTHER MATTER

The results of the previous chapters can be generalized in various ways. One can incorporate hypermultiplets in arbitrary representations. One can add a tower of Kaluza-Klein states. One can study quiver gauge theories. We shall only sketch the results for the fundamental matter, or for five dimensional theories. The other cases will be treated in future publications.

### 7.1. Hypermultiplets in the fundamental representation

In this section  $\mathbf{m}$  denotes the vector of masses:

$$\mathbf{m} = \text{diag}(m_1, \dots, m_k)$$

We will denote by  $\mathbf{f} = 1, \dots, k$  the flavour index.

The partition function of the theory with  $k$  matter hypermultiplets in the fundamental representation of  $U(N)$  is given by the following sum over colored partitions [9]:

$$\begin{aligned} Z(\mathbf{a}, \mathbf{m}; \hbar, \Lambda) &= \sum_{\vec{\mathbf{k}}} \Lambda^{(2N-k)|\vec{\mathbf{k}}|} Z_{\vec{\mathbf{k}}}(\mathbf{a}, \mathbf{m}; \hbar, \Lambda) \\ Z_{\vec{\mathbf{k}}}(\mathbf{a}, \mathbf{m}; \hbar, \Lambda) &= Z^{pert}(\mathbf{a}, \mathbf{m}; \hbar, \Lambda) \prod_{l,i,\mathbf{f}} \frac{\Gamma\left(\frac{m_{\mathbf{f}}+a_l}{\hbar} + k_{li} + 1 - i\right)}{\Gamma\left(\frac{m_{\mathbf{f}}+a_l}{\hbar} + 1 - i\right)} \mu_{\vec{\mathbf{k}}}^2(\mathbf{a}, \hbar) \\ Z^{pert}(\mathbf{a}, \mathbf{m}; \hbar, \Lambda) &= \exp\left(\sum_{l,n} \gamma_{\hbar}(a_l - a_n; \Lambda) + \sum_{l,\mathbf{f}} \gamma_{\hbar}(a_l + m_{\mathbf{f}}; \Lambda)\right) \end{aligned} \quad (7.1)$$

As before, the partition function (7.1) can be written as a sum over profiles  $f = f_{\mathbf{a},\vec{\mathbf{k}}}$  as follows

$$\begin{aligned} Z(\mathbf{a}, \mathbf{m}; \hbar, \Lambda) &= \sum_f Z_f(\mathbf{a}, \mathbf{m}; \hbar, \Lambda) \\ Z_f(\mathbf{a}, \mathbf{m}; \hbar, \Lambda) &= \exp\left(-\frac{1}{4} \int dx dy f''(x) f''(y) \gamma_{\hbar}(x - y; \Lambda) + \right. \\ &\quad \left. \frac{1}{2} \sum_{\mathbf{f}} \int dx f''(x) \gamma_{\hbar}(x + m_{\mathbf{f}}; \Lambda)\right) \end{aligned} \quad (7.2)$$

Observe that the action in (7.2) is the old action (4.25) evaluated at a modified function  $\tilde{f}$  such that

$$\tilde{f}'' = f'' - \sum_{\mathbf{f}} \delta(x + m_{\mathbf{f}}) \quad (7.3)$$

Therefore, the variational problem for the limit shape  $f$  is essentially the variational problem solved in Section 4, the only modification being that the maximizer  $\tilde{f}_*$  is required to have corners at the points  $x = -m_{\mathbf{f}}$ .

We will solve this problem under the assumption that  $m_{\mathbf{f}}$  are real and  $|m_{\mathbf{f}}| \gg 0$ . Without loss of generality, we can assume that the number  $k$  of flavors is exactly  $2N - 1$  since letting some  $m_{\mathbf{f}}$  go to infinity reduces the number of labeled.

Let  $\tilde{\Delta}$  be the half-strip

$$\{|\Re(\varpi)| < N, \Im(\varpi) > 0\},$$

but now with two kinds of vertical slits. As before, we have  $N - 1$  slits going from the points

$$-N + 2l + i\eta_l, \quad l = 1, \dots, N - 1$$

down to the real axis. Additionally, we introduce  $2N - 1$  slits from the points

$$-N + l + i\tilde{\eta}_l, \quad l = 1, \dots, 2N - 1$$

going up to the infinity. Let  $\tilde{\Phi}$  be the conformal map from the upper-half plane to the domain  $\tilde{\Delta}$  as in the following figure

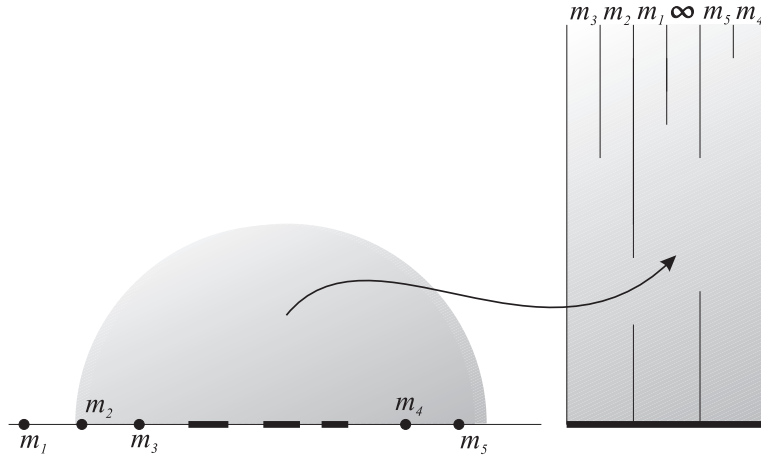

**Fig.12** The map  $\tilde{\Phi}$  for  $N = 3$

The numbers  $\eta_l$  are, as before, the parameters of this map, as well as the number  $\Lambda$ . The numbers  $\tilde{\eta}_l$  are uniquely fixed by the requirement that

$$\Phi^{-1}(\infty) = \{m_1, \dots, m_{2N-1}, \infty\}.$$

Let  $P(z)$  be a monic degree  $N$  polynomial with all real roots. Suppose that  $\Lambda$  is sufficiently small and the  $m_{\mathbf{f}}$ 's are large enough. If

$$m_1 < \dots < m_r \ll 0 \ll m_{r+1} < \dots < m_{2N-1}$$

then, as before, one checks that the map

$$\tilde{\Phi}(z) = \frac{2}{\pi i} \ln \frac{w}{\sqrt{\Lambda}} - N + r + 1, \quad (7.4)$$

where  $w$  is the smaller root of the equation

$$w + \frac{\Lambda}{w} = \frac{P(z)}{\sqrt{Q(z)}}, \quad Q(z) = \prod_{\mathbf{f}=1}^{2N-1} (z + m_{\mathbf{f}}), \quad (7.5)$$

is the required conformal map. Its construction is illustrated in the following figure which is a modification of Fig. 7:

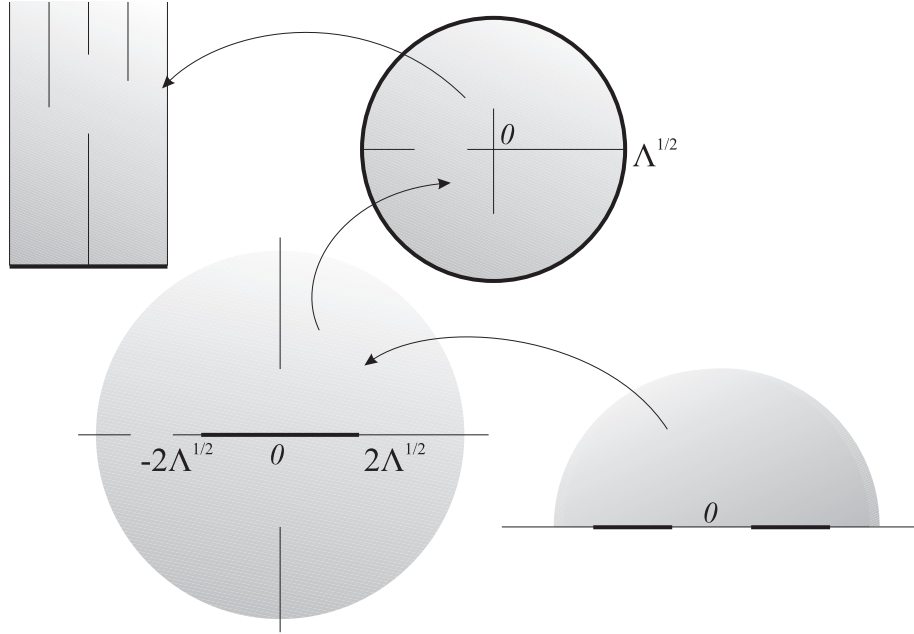

**Fig.13** The map  $\tilde{\Phi}$  as a composition of maps for  $N = 2$

The branch of the logarithm in (7.4) is chosen so that

$$\Im \log(w) \rightarrow 0, \quad z \rightarrow \infty.$$

We now claim that the maximizer  $\tilde{f}_*$  is given by the same formula as before

$$\tilde{f}_*(x)' = \Re \tilde{\Phi}(x), \quad (7.6)$$

which simply means that the nontrivial part of the maximizer  $f_\star$  is determined by the formula

$$f_\star(x)' = \Re \tilde{\Phi}(x), \quad |x| < \min\{|m_{\mathbf{f}}|\}, \quad (7.7)$$

whereas  $f_\star(x) = N|x|$  outside of this interval.

Indeed,  $\tilde{f}_\star(x)'$  clearly has the required jumps at the points  $x = -m_{\mathbf{f}}$ . The equation

$$(\mathbf{X}\tilde{f}_\star)' = -\pi\Im\Phi$$

is checked in the exact same way as before. In particular, the asymptotics

$$\tilde{\Phi}(z) \sim \frac{1}{\pi i} \ln \frac{\Lambda}{z} + \text{real constant}, \quad z \rightarrow \infty \quad (7.8)$$

agrees with the fact that from (4.61) we have

$$(\mathbf{X}\tilde{f}_\star)'(z) = \ln \Lambda - \ln |z| + O\left(\frac{1}{z}\right), \quad z \rightarrow \infty. \quad (7.9)$$

This verifies the predictions of [3][4]. If  $2N = k$  then the curve will be covering elliptic curve, and again can be explicitly constructed.

## 7.2. Five dimensional theory on a circle

Consider five dimensional pure supersymmetric gauge theory with eight supercharges, compactified on the circle  $\mathbf{S}^1$  of circumference  $\beta$ . In addition, put the  $\Omega$ -twist in the noncompact four dimensions. The resulting theory is a deformation of (2.1) by  $\beta$ -dependent terms.

The theory was analyzed in [14][9] and the result of the calculation of the partition function is the following:

$$\begin{aligned} Z(\mathbf{a}; \hbar, \beta, \Lambda) &= \sum_{\vec{\mathbf{k}}} (\beta\Lambda)^{2N|\vec{\mathbf{k}}|} Z_{\vec{\mathbf{k}}}(\mathbf{a}; \hbar, \beta) \\ Z_{\vec{\mathbf{k}}}(\mathbf{a}; \hbar, \beta) &= Z^{pert}(\mathbf{a}; \hbar, \beta) \mu_{\vec{\mathbf{k}}}^2(\mathbf{a}, \beta, \hbar) \\ \mu_{\vec{\mathbf{k}}}^2(\mathbf{a}, \beta, \hbar) &= \prod_{(l,i) \neq (n,j)} \frac{\sinh \frac{\beta}{2}(a_l - a_n + \hbar(k_{l,i} - k_{n,j} + j - i))}{\sinh \frac{\beta}{2}(a_l - a_n + \hbar(j - i))} \\ Z^{pert}(\mathbf{a}; \hbar, \beta) &= \Lambda^{\frac{1-N^2}{12}} \exp \sum_{l,n} \gamma_{\hbar}(a_l - a_n | \beta; \Lambda) \end{aligned} \quad (7.10)$$

Note that we included a power of  $\beta$  in  $\Lambda$  in (7.10) in order to have a simple four dimensional limit  $\beta \rightarrow 0$ ,  $\Lambda$  finite. This “renormalization” group relation was actually derived in [6][14].

### 7.2.1. Path representation

The partition function (7.10) is easily written as a path sum:

$$Z(\mathbf{a}; \hbar, \beta, \Lambda) = \sum_{f \in \Gamma_{\mathbf{a}}} \exp \left( -\frac{1}{4} \int_{x \neq y} f''(x) f''(y) \gamma_{\hbar}(x - y | \beta; \Lambda) \right) \quad (7.11)$$

### 7.2.2. Prepotential

From (7.11) we derive, as before, the equations on the critical path, which, in turn, determine the prepotential. Assuming  $\beta > 0$ , we have

$$\mathcal{F}_0(\mathbf{a}, \beta, \Lambda) = \frac{1}{4} \mathcal{E}_{\beta}(f_{\star}), \quad (7.12)$$

where  $f_{\star}$  is the maximizer and the functional  $\mathcal{E}_{\beta}$  is defined by:

$$\mathcal{E}_{\beta}(f) = \int_{x < y} dx dy (N + f'(x))(N - f'(y)) \log \left( \frac{2}{\beta \Lambda} \sinh \frac{\beta |x - y|}{2} \right). \quad (7.13)$$

Again, we modify the functional (7.12) by a surface energy term to obtain the following total action functional:

$$\mathcal{S}(f) = \frac{1}{4} \mathcal{E}_{\beta}(f) + \frac{1}{2} \int_{\mathbf{R}} \sigma(f') dx \quad (7.14)$$

We now introduce a five dimensional analogue of the transform  $\mathbf{X}f$  (see appendix **A** for the definition of the function  $\gamma_0(x; \beta)$ ):

$$[\mathbf{X}_{\beta} f](x) = \frac{1}{2} \int_{y \neq x} dy \operatorname{sgn}(y - x) \gamma_0'(|y - x|; \beta) f''(y). \quad (7.15)$$

Note that the relation

$$\gamma_0(x; \beta)'' = \log \frac{2}{\beta \Lambda} \sinh \frac{\beta x}{2}, \quad (7.16)$$

implies that

$$[\mathbf{X}_{\beta} f]'(x) = -\frac{1}{2} \int_{y \neq x} dy \log \left( \frac{2}{\beta \Lambda} \sinh \frac{\beta |x - y|}{2} \right) f''(y). \quad (7.17)$$

The equations on the minimizer for (7.14) are formulated exactly as in the Proposition (4.45) with the replacement of  $\mathbf{X}f$  by  $\mathbf{X}_{\beta} f$ .

The solutions to these equations can be constructed as follows. Let  $\Phi(z)$  be the conformal map from the horizontal strip

$$0 < \Im z < \frac{\pi}{\beta} \quad (7.18)$$

to the slit half-strip  $\tilde{\Delta}$  with  $N - 1$  slits of the form (4.48) and an additional vertical semi-infinite slit

$$\Re w = 0, \quad \Im w > \tilde{\eta},$$

as in Section 7.1 above. We normalize  $\Phi$  by the requiring that it maps the two ends of the horizontal strip to the two ends of  $\tilde{\Delta}$ . This fixes it up to precomposing with an overall shift by a real constant.

The exponential map

$$z \mapsto X = e^{\beta z}$$

maps the strip (7.18) to the upper half-plane, mapping  $\mathbf{R}$  to  $\mathbf{R}_{>0}$ . Therefore, we can use the results of the previous section to conclude that  $\Phi$  has the form

$$\Phi(z) = N + \frac{2}{\pi i} \log w,$$

where  $w$  is the smaller root of the equation

$$X^{-\frac{N}{2}} P_N(X) = (\beta \Lambda)^N \left( w + \frac{1}{w} \right), \quad X = e^{\beta z}. \quad (7.19)$$

Here  $P_N$  is a monic polynomial of degree  $N$  and  $\log w$  is normalized, as usual, by the requirement that  $\Im \log w \rightarrow 0$  as  $z \rightarrow +\infty$  along the real axis.

In the form (7.19), the parameter  $\tilde{\eta}$  of the map  $\Phi$  becomes a function of  $\Lambda$  and other parameters. The equation (7.19) defines the spectral curve of the relativistic Toda chain, as predicted in [14].

Applying the Schwarz reflection principle to any vertical part of the boundary of  $\tilde{\Delta}$  and taking the resulting function modulo 1, we obtain a  $2N$ -fold map from the horizontal cylinder of circumference  $2\pi/\beta$  with  $N$  cuts along the real axis to the unit half-cylinder, as shown in the following figure

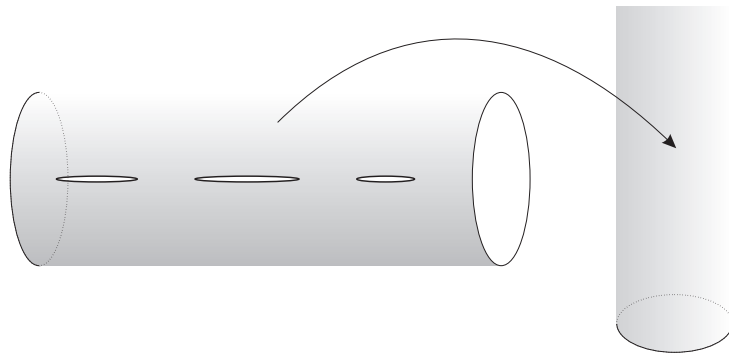

**Fig.14** The map  $\Phi \bmod 1$

Here each cut covers 2-to-1 the finite boundary of the half-cylinder, while both ends of the cylinder cover  $N$ -to-1 each the infinite end of the half-cylinder.

As before, it follows that  $\Phi'(z)$  extends to a  $2\pi i/\beta$ -periodic function in the entire complex plane with  $N$  cuts along the real axis, periodically repeated. The values of  $\Phi'(z)$  on the two sides of the cut are real and opposite in sign. We have

$$\Phi(x + i0) = \pm \left( i \frac{N\beta x}{\pi} + N \right) + \frac{2N}{\pi i} \log \beta\Lambda, \quad x \rightarrow \pm\infty, \quad (7.20)$$

whence

$$\Phi'(x + i0) = \mp \frac{N\beta}{\pi i}, \quad x \rightarrow \pm\infty, \quad (7.21)$$

It follows that the function  $\Phi'(z)$  satisfies the following integral equation

$$\Phi'(z) = \frac{\beta}{2\pi i} \int_{\mathbf{R}} \Re\Phi'(x) \coth \left( \beta \frac{(x-z)}{2} \right) dx. \quad (7.22)$$

Moreover, by comparing the asymptotics, we can integrate (7.22) to

$$\Phi(z) = N + \frac{i}{\pi} \int_{\mathbf{R}} \Re\Phi'(x) \log \left( \frac{2}{\beta\Lambda} \sinh \frac{\beta(z-x)}{2} \right) dx. \quad (7.23)$$

We claim that the maximizer  $f_\star$  is given in terms of the map  $\Phi$  by the usual formula

$$f'_\star(x) = \Re\Phi(x + i0).$$

Indeed, from (7.23) and (7.17) we conclude that

$$(\mathbf{X}_\beta f_\star)'(x) = -\frac{\pi}{2} \Im\Phi(x). \quad (7.24)$$

The difference with the previously considered cases lies in the fact that to reconstruct the values of  $\xi_l$ 's (and  $a_l$ 's) we have to integrate the multi-valued differential

$$dS_5 = \frac{1}{\beta} \log(X) \frac{dw}{w}$$

on the curve (7.19), as indeed proposed in [14]. Also note that domain where the map  $\Phi$  is defined is different. This leads to the new form of the Seiberg-Witten differential.

### 7.2.3. Free field representation

Again we start with  $N = 1$  case. Let  $Q = e^{\beta\hbar}$ . In this case we are to sum over all partitions:

$$Z(a, \hbar, \beta, \Lambda) = \sum_{\mathbf{k}} (-1)^{|\mathbf{k}|} (\beta\Lambda)^{2|\mathbf{k}|} \prod_{\square \in \mathbf{k}} \left( \frac{\beta}{2 \sinh \left( \frac{\beta\hbar h(\square)}{2} \right)} \right)^2 = \exp \sum_{n=1}^{\infty} \frac{(\beta\Lambda)^{2n}}{4n \sinh^2 \left( \frac{\beta\hbar n}{2} \right)} \quad (7.25)$$

The free field representation of the sum (7.25) is most simply done using the vertex operators:

$$\Gamma_{\pm}(\beta, \hbar) = \exp \sum_{\pm n > 0} \frac{1}{n(1 - Q^n)} \mathcal{J}_n \quad (7.26)$$

Then

$$Z(a, \hbar, \beta, \Lambda) = \langle 0 | \Gamma_+(\beta, \hbar) (\beta\Lambda)^{2L_0} \Gamma_-(\beta, \hbar) | 0 \rangle \quad (7.27)$$

and, for  $N > 1$  we would get:

$$Z^D(\xi; p; \beta, \hbar, \Lambda) = \langle p | \Gamma_+(\beta, \hbar) (\beta\Lambda)^{2L_0} e^{\mathbf{H}\xi} \Gamma_-(\beta, \hbar) | p \rangle \quad (7.28)$$



## 8. CONCLUSIONS AND FUTURE DIRECTIONS

### 8.1. Future directions and related work

In this paper we extensively analyzed the partition functions of various  $\mathcal{N} = 2$  supersymmetric gauge theories, subject to the  $\Omega$ -background of  $\mathcal{N} = 2$  supergravity. In all cases the partition function was identified with the statistical sum of an ensemble of random partitions with various Boltzmann weights. The grand canonical ensemble corresponds to the fixed theta angle in the gauge theory. In the thermodynamic limit the statistical sums are dominated by a saddle point, a master partition, from which one can extract easily various important characteristics of the low-energy effective gauge theory, such as the prepotential of the effective action, which is identified with the free energy per unit volume in the dual statistical model, provided we relate the volume to the parameters  $\epsilon_1, \epsilon_2$  of the  $\Omega$ -background, via

$$V = \frac{1}{\epsilon_1 \epsilon_2} .$$

The particle number is clearly the instanton charge. So the gauge theory partition function corresponds to the grand canonical ensemble, with  $\log(\Lambda)$  being the chemical potential. The average particle number per unit volume, the density, is easy to determine:

$$\begin{aligned} \rho = \left\langle \frac{k}{V} \right\rangle &= \frac{\epsilon_1 \epsilon_2}{2N Z^{inst}(\mathbf{a}, \epsilon_1, \epsilon_2, \Lambda)} \frac{\partial}{\partial \log(\Lambda)} Z^{inst}(\mathbf{a}, \epsilon_1, \epsilon_2, \Lambda) \xrightarrow{V \rightarrow \infty} \\ &= \frac{1}{2N} \frac{\partial}{\partial \log(\Lambda)} \mathcal{F}_0^{inst}(\mathbf{a}, \Lambda) = u_2 - \sum_l \frac{a_l^2}{2} \end{aligned} \quad (8.1)$$

(recall (4.5)). In the region  $\mathcal{U}_\infty$  the right hand side of (8.1) is clearly very small, it is of the order:

$$\rho \sim \frac{\Lambda^{2N}}{a^{2(N-1)}} \sim M_W^2 e^{-\frac{8\pi^2}{g_{eff}^2(M_W)}}$$

where  $M_W$  is the typical  $W$ -boson mass, and  $g_{eff}(M_W)$  is the effective coupling at this scale. The dependence of the instanton density on the coupling is the typical one in the dilute gas approximation (cf. [23][69]). In the semi-classical region there are very few instantons per unit volume.

Of course, a cautious reader may wonder about the dimensionality of the instanton density (which normally should be  $(\text{mass})^4$ ). The point is that the noncommutative regularization which we used in the calculations introduces a scale  $\sim \sqrt{\Theta}$ , which is responsible for the dimensional transmutation we see in (8.1). Indeed, the physical volume, occupied

by  $k$  instantons, sitting on top of each other, is roughly  $k\Theta^2$ . Such instanton “foam” [70], or perhaps, liquid, may well be related to more complicated phenomenological pictures, say instanton liquid [71]. Moreover, as we go deeper into the moduli space of vacua, the diluteness of the instanton gas also must cease to hold. However, the analytic properties of the partition function (3.2) are powerful enough to uniquely fix it by the instanton gas expansion in  $\mathcal{U}_\infty$ .

Note, that one of the interpretations of our result is the existence of the master field in the  $\mathcal{N} = 2$  gauge theories, which, however, is working only for special (chiral) observables, unlike the master field of the large  $N$  gauge theories [72]. The latter, however, is much more elusive.

In our story, the master field is constructed as follows. First of all, the labeled partitions  $\vec{\mathbf{k}}$  we sum over are in one-to-one correspondence with the (noncommutative) gauge fields, describing certain arrangements of the nearly point-like instantons, sitting nearly on top of each other. The “master” partition with the profile  $f_\star$  corresponds to statistically most favorable configuration.

We extensively exploited in this paper the fact that  $\Omega$ -background acts as a box, similarly, in some respects, to the AdS space for the supergravity theory. One may wonder, why couldn’t we use the more traditional ways of regularizing infrared divergences of the gauge theory. In fact, the number of options is rather limited. One may study gauge theories on the compact four manifolds. To preserve supersymmetry one needs to turn on certain non-minimal couplings, which effectively twist the gauge theory. However, in these approaches one cannot learn directly the properties of the gauge theory in the infinite volume, as all vacua are averaged over, and either most of them do not contribute to the correlation functions of the chiral operators (which is the case for the simple type manifolds), or (for the manifolds with  $b_2^+ \leq 1$ ) the contribution of the various vacua is related to the prepotential in a complicated fashion [73][74]. It is out of such attempts to regulate the  $\mathcal{N} = 2$  theory that one naturally arrives at the concept of the  $\Omega$ -background.

The topic which we completely neglected in our paper is the application of our formalism to the theories with  $\mathcal{N} = 1$  supersymmetry. Recently, there was a lot of excitement related to the exact calculations of the effective *superpotentials* of the theories, obtained from  $\mathcal{N} = 2$  theories by the superpotential deformations [8][75][76]. It should be straightforward to apply our techniques in these setups as well. One encouraging feature of our formalism in the case of pure  $\mathcal{N} = 2$  and softly broken  $\mathcal{N} = 4$  theories, is the striking similarity of the expression we have for the partition functions and the matrix models

calculating the effective superpotentials of the  $\mathcal{N} = 1$  gauge theories with an additional adjoint chiral multiplet, or with three adjoint chiral multiplets, with specific superpotential.

The similarity is the measure — in the first case it is the regularized Vandermonde determinant of the infinite matrix  $\widehat{\Phi}$  with the eigenvalues  $a_l + \hbar(k_{li} - i)$ . In the second case it is the ratio of the determinants:

$$\frac{\text{Det}'(ad\widehat{\Phi})}{\text{Det}(ad\widehat{\Phi} + \mathbf{m})}$$

The fact that the eigenvalues concentrate (for small  $\hbar$ ) around  $a_l$ 's also has a matrix model counterpart. Namely, to get the theory with  $U(1)^N$  gauge symmetry one adds to the  $U(N)$  theory a tree-level superpotential with extrema near  $a_1, \dots, a_N$ . In the limit of vanishing superpotential one is left essentially with the Haar measure on matrices, together with the prescription to distribute eigenvalues near the extrema of the phantom of the superpotential [8].

The differences are also easy to see: on our case the matrix is infinite, but the eigenvalues are discrete and are summed over. In the Dijkgraaf-Vafa case, the matrix is finite, but the eigenvalues are continuous and integrated over. We have  $\hbar \rightarrow 0$ , they have  $\widehat{N} \rightarrow \infty$ . The issue is tantalizing and is under investigation [77].

*Oh, East is East, and West is West, and never the twain shall meet, . . .*

Another issue which we didn't touch much upon is the string theory dual of our calculation. There are several points one may want to stress.

First of all, the summation over partitions that we encountered is very similar to the summation over partitions one encounters in the two dimensional  $U(\widehat{N})$  Yang-Mills theory, in the large  $\widehat{N}$  limit. In particular, when working on a two-sphere, one finds a master partition [78], and moreover, for the values of the 't Hooft coupling constant the profile of the master partition has the facets, just like ours.

Of course, technically speaking, the two dimensional YM theory corresponds to the  $U(1)$  theory in our case, and the 't Hooft coupling there corresponds to the higher Casimir coupling  $\tau_3$  in our game. But the phenomena have similar origin. Now, the two dimensional Yang-Mills theory has a dual closed string representation [79], and so does our four dimensional partition function. And again, just like  $1/\widehat{N}$  played the rôle of the string coupling constant,  $\hbar$  plays this rôle in the four dimensional story.

In the  $U(1)$  case all this is more or less well-known [36][10] by now. However, the full string dual of the  $U(N)$  theory is yet to be discovered (see [10] for the discussion, see also [80][81]).

We should add that from the point of view of Gromov-Witten theorists the dual type A topological string theory, whatever it is, must be rather simple. Most of them should have one dimensional target spaces. The rough correspondence between the gauge theory and the dual GW theory states that the  $U(N)$  theory with  $g$  adjoint hypermultiplets (which is not asymptotically free/conformal for  $g > 1$ ) is dual to the GW theory of  $N$  copies of the Riemann surface of genus  $g$ . The words “ $N$  copies” still do not quite have a formal meaning.

In the large  $\widehat{N}$  description of the two dimensional Yang-Mills theory a prominent rôle was played by the formalism of free fermions [53]. Of course, the chiral fermions of [53] are ours  $\Psi, \widetilde{\Psi}$  (somehow four dimensional gauge theories do not see the anti-chiral sector).

One of the exciting problems is to understand better the nature of these chiral fields in the string realizations of  $\mathcal{N} = 2$  gauge theories. The conjecture of [9] was that they arise as the modes of the chiral two form propagating on the worldvolume of the NS5/M5 brane, trapped by the  $\Omega$ -background. In the bosonized form, these can also be mapped to the truncated version of the Kodaira-Spencer field, propagating along the Seiberg-Witten curve. We are planning to investigate these issues in the future.

Yet another exciting area of research, revolving around our partition functions is their two dimensional (anyonic) interpretation in the  $\nu \neq 1$  case. The connections to the Jack polynomials, which are the eigenfunctions of the Sutherland many-body Hamiltonians with  $\nu(\nu - 1)$  coupling constant, suggest strongly some relations to the physics of the quantum Hall effect, and also to the theory of analytic maps [82]. The latter also seem to be responsible for the higher Casimir deformation (4.73).

Seiberg-Witten curve itself seems to arise as some quasiclassical object in the theory of some many-body ( $\widehat{N} \rightarrow \infty$ ) system. Indeed, the space  $z, w$  where it is embedded, can be viewed as a one-particle phase space. The particles are basically free for  $\nu = 1$ , and have some phantom interaction for  $\nu \neq 0, 1$ , which only reveals itself in the generalized Pauli exclusion principle (Haldane exclusion principle). They fill some sort of Fermi sea, bounded by the Seiberg-Witten curve. Perhaps, the relation to the random dimers [47] will also prove useful in understanding these issues. Another possibly useful feature of our energy functional is its simple relation to the two dimensional local theory of a free boson. Indeed, the bi-local part of (4.36) is nothing but the induced boundary action, with  $\rho(x)$  being the boundary condition in the theory of the free boson, living on the upper half-plane. Of course, when the subleading in  $\hbar$  corrections are taken into account the theory will cease to be free. It is also interesting to point out that our extremizing configuration  $f_\star(x)$  corresponds to some sort of multiple D-brane boundary state, with  $N$  D-branes located at  $x \sim a_l, l = 1, \dots, N$ .

It is of course very tempting to develop these pictures further, connect instanton gas/liquid/crystal to the (Luttinger?) liquid of the dual anyons, and learn more about the properties of the fivebranes from all this. Perhaps, the results of [83][84] will prove useful along this route.

Finally, the theory with adjoint matter should be closely related to conformal field theory on an elliptic curve. We have uncovered some of the relation in the partition function being interpreted as a trace in the representation of a current algebra. We should also note that the elliptic Calogero-Moser system, whose spectral curve, as we showed above, encodes the quasiclassical/thermodynamic limit of the partition function, allows a nonstationary generalization, related to KZB equations, which, conjecturally, governs our full partition function [85][86][87][88][89][90].

## 8.2. Summary of the results

In this paper we have advanced in the study of the vacuum structure of gauge theories. We considered  $\mathcal{N} = 2$  supersymmetric gauge theories in four dimensions, and have subject them to the so-called  $\Omega$ -background. In this background one can calculate exactly the partition function, in any instanton sector. The result has the form of a statistical sum of the ensemble of random partitions. The limit where the  $\Omega$ -background approaches flat space, is the most interesting for the applications, as there one is supposed to learn about the properties of the supersymmetric gauge theory in flat spacetime. In terms of the random partitions this is a thermodynamic, or quasiclassical limit. The flat space limit of the free energy coincides with the prepotential of the low-energy effective theory.

We have evaluated the sum over instantons, by applying the saddle point method, and thus have succeeded (to our knowledge, for the first time in the literature) in producing the all-instanton direct calculation of the prepotential.

In all cases considered: pure gauge theory, theory with the matter hypermultiplets, five dimensional theory compactified on a circle – the saddle point corresponds to some *master partition*, which is the analogue of the *eigenvalue distribution* in the theory of random matrices. And in all cases one can encode the solution in some family of algebraic curves, endowed with a meromorphic (sometimes multivalued) differential, whose periods contain the information about the prepotential.

We have also found interesting representation of the full partition function (which, in addition to the prepotential, contains also certain higher gravitational couplings  $\mathcal{F}_g$  of the gauge theory) as a partition function of the theory of chiral fermions/bosons on a sphere (for the pure gauge theory), on a torus (for the theory with adjoint matter), or some  $q$ -analogue thereof (for the five dimensional theory).

We have also uncovered numerous puzzling relations between various seemingly unrelated topics which leave a lot of work for the future.

**Disclaimer.** Opinions presented in this paper do not necessarily reflect author's point of view. There are about  $\sim 2\pi\%$  misprints in this paper. We are however confident that the most of them cancel each other.

## Appendix A. The function $\gamma_{\hbar}(x; \Lambda)$

### A.0.1. Free case: $\epsilon_2 = -\epsilon_1 = \hbar$

The function  $\gamma_{\hbar}(x; \Lambda)$  is characterized by the following properties:

1. Asymptotic expansion for  $\hbar \rightarrow 0$ :

$$\gamma_{\hbar}(x; \Lambda) = \sum_{g=0}^{\infty} \hbar^{2g-2} \gamma_g(x) \quad (\text{A.1})$$

2. Finite-difference equation:

$$\gamma_{\hbar}(x + \hbar; \Lambda) + \gamma_{\hbar}(x - \hbar; \Lambda) - 2\gamma_{\hbar}(x; \Lambda) = \log\left(\frac{x}{\Lambda}\right) \quad (\text{A.2})$$

The conditions (A.1)(A.2) specify  $\gamma_{\hbar}(x; \Lambda)$  uniquely up to a linear function in  $x$ . All the terms  $\gamma_g(x)$ ,  $g > 0$  are uniquely determined:

$$\begin{aligned} \gamma_0(x) &= \frac{1}{2}x^2 \log\left(\frac{x}{\Lambda}\right) - \frac{3}{4}x^2 \\ \gamma_1(x) &= -\frac{1}{12} \log\left(\frac{x}{\Lambda}\right) \\ \gamma_2(x) &= -\frac{1}{240} \frac{1}{x^2} \\ &\vdots \\ \gamma_g(x) &= \frac{B_{2g}}{2g(2g-2)} \frac{1}{x^{2g-2}}, \quad g > 1 \end{aligned} \quad (\text{A.3})$$

where  $B_n$ 's are the usual Bernoulli numbers:

$$\frac{t}{e^t - 1} = \sum_{n=0}^{\infty} \frac{B_n}{n!} t^n$$

The function  $\gamma_{\hbar}(x; \Lambda)$  is closely related to the gamma function:

$$\gamma_{\hbar}\left(x + \frac{\hbar}{2}; \Lambda\right) - \gamma_{\hbar}\left(x - \frac{\hbar}{2}; \Lambda\right) = \log\left(\frac{1}{\sqrt{2\pi}} \hbar^{\frac{x}{\hbar}} \Gamma\left(\frac{1}{2} + \frac{x}{\hbar}\right)\right) \quad (\text{A.4})$$

Another definition of the function  $\gamma_{\hbar}(x; \Lambda)$  is through the zeta-regularization:

$$\gamma_{\hbar}(x; \Lambda) = \frac{d}{ds} \Big|_{s=0} \frac{\Lambda^s}{\Gamma(s)} \int_0^{\infty} \frac{dt}{t} t^s \frac{e^{-tx}}{(e^{\hbar t} - 1)(e^{-\hbar t} - 1)} \quad (\text{A.5})$$

**Remark:** Note, that

$$\gamma_{\hbar}(0; \Lambda) = -\frac{1}{12}$$

The function  $\gamma_{\hbar}(x; \Lambda)$  for  $\Lambda = 1$  arises as the free energy of the  $c = 1$  string with  $\hbar$  being the string coupling, and  $x$  the cosmological constant. It is also related to the free energy of the topological type A string on the conifold (see also below). The adepts of the applications of matrix models in susy gauge theories [8] praise yet another property of  $\gamma_{\hbar}(x; \Lambda)$ :

$$\log(\text{Vol}U(N)) = \gamma_1(N; 1) \quad (\text{A.6})$$

### A.0.2. Anyon case: general $\epsilon_1, \epsilon_2$

$$\gamma_{\epsilon_1, \epsilon_2}(x; \Lambda) = \frac{d}{ds} \Big|_{s=0} \frac{\Lambda^s}{\Gamma(s)} \int_0^{\infty} \frac{dt}{t} t^s \frac{e^{-tx}}{(e^{\epsilon_1 t} - 1)(e^{\epsilon_2 t} - 1)} \quad (\text{A.7})$$

In the case  $\epsilon_2 = -\epsilon_1 = \hbar$  this reduces to  $\gamma_{\hbar}(x; \Lambda)$ :

$$\gamma_{\hbar}(x; \Lambda) = \gamma_{-\hbar, \hbar}(x; \Lambda)$$

The *main difference equation*:

$$\gamma_{\epsilon_1, \epsilon_2}(x; \Lambda) + \gamma_{\epsilon_1, \epsilon_2}(x - \epsilon_1 - \epsilon_2; \Lambda) - \gamma_{\epsilon_1, \epsilon_2}(x - \epsilon_1; \Lambda) - \gamma_{\epsilon_1, \epsilon_2}(x - \epsilon_2; \Lambda) = \log\left(\frac{\Lambda}{x}\right) \quad (\text{A.8})$$

*Reflection*:

$$\gamma_{-\epsilon_1, \epsilon_2}(x; \Lambda) = -\gamma_{\epsilon_1, \epsilon_2}(x - \epsilon_1; \Lambda) - \frac{2x + \epsilon_1}{2\epsilon_2} \log(\Lambda) \quad (\text{A.9})$$

For  $\nu \in \mathbf{Q}$  the function  $\gamma_{\epsilon_1, \epsilon_2}(x; \Lambda)$  can be related to  $\gamma_{\hbar}(x; \Lambda)$ . Suppose

$$\epsilon_1 = -\frac{\hbar}{p}, \quad \epsilon_2 = \frac{\hbar}{q}, \quad p, q \in \mathbf{N}. \quad (\text{A.10})$$

Then

$$\gamma_{\epsilon_1, \epsilon_2}(x; \Lambda) = \sum_{i=0}^{p-1} \sum_{j=0}^{q-1} \gamma_{\hbar}\left(x + \frac{\hbar}{pq}(pj - qi); \Lambda\right) \quad (\text{A.11})$$



### A.0.3. Trigonometric analogue of $\gamma_{\epsilon_1, \epsilon_2}(x; \Lambda)$

The natural generalization of (A.7) is the function:

$$\gamma_{\epsilon_1, \epsilon_2}(x|\beta; \Lambda) = \frac{1}{2\epsilon_1\epsilon_2} \left( -\frac{\beta}{6} \left( x + \frac{1}{2}(\epsilon_1 + \epsilon_2) \right)^3 + x^2 \log(\beta\Lambda) \right) + \sum_{n=1}^{\infty} \frac{1}{n} \frac{e^{-\beta nx}}{(e^{\beta n\epsilon_1} - 1)(e^{\beta n\epsilon_2} - 1)} \quad (\text{A.12})$$

which obeys:

The *main Q-difference equation*:

$$\begin{aligned} \gamma_{\epsilon_1, \epsilon_2}(x|\beta; \Lambda) + \gamma_{\epsilon_1, \epsilon_2}(x - \epsilon_1 - \epsilon_2|\beta; \Lambda) - \gamma_{\epsilon_1, \epsilon_2}(x - \epsilon_1|\beta; \Lambda) - \gamma_{\epsilon_1, \epsilon_2}(x - \epsilon_2|\beta; \Lambda) = \\ - \log \left( \frac{2}{\beta\Lambda} \sinh \frac{\beta x}{2} \right) \end{aligned} \quad (\text{A.13})$$

We shall only use in this paper the special case  $\epsilon_2 = -\epsilon_1 = \hbar$ , where we get the function

$$\begin{aligned} \gamma_{\hbar}(x; \beta; \Lambda) &= \frac{\beta x^3}{12\hbar^2} - \frac{x^2}{2\hbar^2} \log(\beta\Lambda) - \frac{\beta x}{24} + \sum_{n=1}^{\infty} \frac{1}{n} \frac{e^{-\beta nx}}{(e^{-\beta n\hbar} - 1)(e^{\beta n\hbar} - 1)} \\ &= \sum_{g=0}^{\infty} \gamma_g(x; \beta) \hbar^{2g-2} \\ \gamma_0(x; \beta) &= -\frac{x^2}{2} \log(\beta\Lambda) + \beta \frac{x^3}{12} - \frac{1}{\beta^2} \text{Li}_3(e^{-\beta x}) \\ \gamma_1(x; \beta) &= -\frac{1}{12} \log \left( 2 \sinh \frac{\beta x}{2} \right) \\ \gamma_g(x; \beta) &= \frac{B_{2g} \beta^{2g-2}}{2g(2g-2)} \text{Li}_{3-2g}(e^{-\beta x}) \end{aligned} \quad (\text{A.14})$$

Note that up to the terms of instanton degree zero the function  $\gamma_{\hbar}(x|\beta; \Lambda)$  coincides with the all-genus free energy of the type A topological string on the resolved conifold, with  $\beta x$  being the Kähler class of the  $\mathbf{P}^1$ , and  $\beta\hbar$  the string coupling [91]. Another Gromov-Witten interpretation is via the local  $\mathbf{F}_1$ , with the Kähler class of the base  $\mathbf{P}^1$  being  $\log(\beta\Lambda)$  (considered to be big), and the fiber  $\mathbf{P}^1$  with the Kähler class  $\beta x$  [6].

## Appendix B. Partitions, charges, colours

*Partition*: a nonincreasing sequence of nonnegative integers, stabilizing at some point at zero:

$$\mathbf{k} : k_1 \geq k_2 \geq \dots \geq k_n > 0 = k_{n+1} = k_{n+2} = \dots$$

$n \equiv \ell(\mathbf{k})$  is called the *length* of  $\mathbf{k}$ ,

$|\mathbf{k}| = \sum_i k_i$ , is called the *size* of the partition,  $k_i$ 's are called the *parts* of the partition.

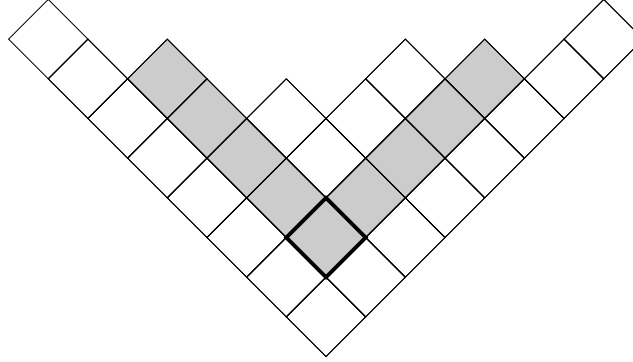

**Fig.15** Box, hook, ....

The parts of a partition are labeled by  $i, j = 1, 2, \dots$ ,

For the partition  $\mathbf{k}$ :

$$\square = (i, j) \in \mathbf{k} \iff 1 \leq i, \quad 1 \leq j \leq k_i$$

*Dual partition*:  $\tilde{\mathbf{k}}$ ,

$$(i, j) \in \tilde{\mathbf{k}} \iff (j, i) \in \mathbf{k}$$

i.e.  $\tilde{k}_i = \#\{j | i \leq k_j\}$

*Hook-length*  $h_{i,j} = h(\square)$  of the  $(i, j)$  box in the Young diagram of the partition  $\mathbf{k}$ :

$$h_{i,j} = \tilde{k}_j + k_i - i - j + 1$$

*Coloured partition*:  $\vec{\mathbf{k}}$ , the  $N$ -tuple of partitions:

$$\vec{\mathbf{k}} = (\mathbf{k}_1, \dots, \mathbf{k}_N),$$

individual partitions are denoted as:

$$\mathbf{k}_l = (k_{l,1} \geq k_{l,2} \geq \dots \geq k_{l,n_l} > k_{l,n_l+1} = 0 = \dots),$$

$$|\vec{\mathbf{k}}| = \sum_{l,i} k_{li}$$

*Charged partition:*  $(p; \mathbf{k})$ , the set of nonincreasing integers  $\kappa_i = k_i + p$ , where

$$\mathbf{k} = (k_1 \geq k_2 \geq \dots)$$

is a partition, and  $p \in \mathbf{Z}$ . The limit  $\kappa_\infty \equiv p$  is called the *charge*.

*Blending of coloured partitions:* given a vector  $\vec{p} = (p_1, \dots, p_N)$ , with

$$\sum_l p_l = 0$$

and an  $N$ -tuple of partitions  $\vec{\mathbf{k}}$ , we define the *blended* partition  $K$ , as follows:

$$\{K_i - i \mid i \in \mathbf{N}\} = \{N(k_{li} - i + p_l) + l - 1 \mid l = 1, \dots, N, i \in \mathbf{N}\} \quad (\text{B.1})$$

#### B.0.4. Power-sums

To the charged partition  $(p; \mathbf{k})$  it is useful to associate the following shifted-symmetric generating function, analytic in  $t$ , with a single pole at  $t = 0$ , defined for  $\Re t > 0$  by the series:

$$\mathbf{p}_{p;\mathbf{k}}(t) = \sum_{i=1}^{\infty} e^{t(p+k_i-i+\frac{1}{2})} \quad (\text{B.2})$$

The expansion of  $\mathbf{p}_{p;\mathbf{k}}(t)$  near  $t = 0$  contains information about the charge, the size of  $\mathbf{k}$ , etc:

$$\mathbf{p}_{p;\mathbf{k}}(t) = \frac{1}{t} + p + t \left( \frac{p^2}{2} + |\mathbf{k}| - \frac{1}{24} \right) + \dots \quad (\text{B.3})$$

•

Given  $N$  partitions  $\mathbf{k}_l$ ,  $l = 1, \dots, N$ , and the charges  $p_l \in \mathbf{Z}$ , we associate to them the generating function:

$$\mathbf{p}_{\vec{p};\vec{\mathbf{k}}}(t) = \sum_{l,i} e^{t \left( N(p_l + k_{l,i} - i) + l - \frac{1}{2} \right)} = \sum_l e^{Nt p_l} \mathbf{p}_{p_l, \mathbf{k}_l}(Nt) \quad (\text{B.4})$$

which corresponds to the blended partition  $\mathbf{K}$  of charge:

$$p = \sum_l p_l = \sum_l \tilde{p}_l \quad (\text{B.5})$$

and size:

$$|\mathbf{K}| = \sum_I K_I = N \sum_l \left( \frac{1}{2} \tilde{p}_l^2 + |\mathbf{k}_l| \right) - \frac{1}{2} p^2 - \frac{N^2 - 1}{24} \quad (\text{B.6})$$

where

$$\tilde{p}_l = p_l + \rho_l$$

•

The function  $f_{p;\mathbf{k}}(x)$  is related to  $\mathbf{p}_{p;\mathbf{k}}(t)$  by the integral transformation:

$$f''_{p;\mathbf{k}}(x) = -\frac{1}{\pi i} \int_{\mathbf{R}} dt e^{-itx} \sin \frac{t\hbar}{2} \mathbf{p}_{p;\mathbf{k}}(it\hbar) \quad (\text{B.7})$$

The resolvent (4.20) is related to  $\mathbf{p}_{p;\mathbf{k}}(t)$  by another integral transformation:

$$R(z|\epsilon_1, \epsilon_2) = -\frac{1}{\pi i} \int_0^\infty dt e^{-tz} \sinh \frac{t\hbar}{2} \mathbf{p}_{p;\mathbf{k}}(t\hbar) \quad (\text{B.8})$$

## Appendix C. Theta-function

For completeness we list here the relevant formulae for the odd theta function, which we use in (6.32).

$$\begin{aligned}
 \theta_{11}(\varpi; \tau) &= \sum_{n \in \mathbf{Z}} e^{\pi i \tau (n + \frac{1}{2})^2 + 2\pi i (\varpi + \frac{1}{2})(n + \frac{1}{2})} \\
 \theta_{11}(\varpi + 1; \tau) &= -\theta_{11}(\varpi; \tau) \\
 \theta_{11}(\varpi + \tau; \tau) &= -e^{-\pi i (2\varpi + \tau)} \theta_{11}(\varpi; \tau)
 \end{aligned} \tag{C.1}$$

From these formulae one easily concludes that the Lax operator  $L(\varpi)$  (6.32) is the meromorphic Higgs operator in the rank  $N$  vector bundle over the elliptic curve  $E_\tau$ , twisted by the one dimensional affine bundle, which makes its spectrum to live in the affine bundle as well.

In (6.12) we use Dedekind eta-function:

$$\eta(q) = q^{\frac{1}{24}} \prod_{n=1}^{\infty} (1 - q^n), \quad q = e^{2\pi i \tau} \tag{C.2}$$

## References

- [1] V. Novikov, M. Shifman, A. Vainshtein, V. Zakharov, Nucl. Phys. **B229** (1983) 381, Nucl. Phys. **B260** (1985) 157-181, Phys.Lett. **217B** (1989) 103
- [2] N. Seiberg, Phys.Lett. **206B** (1988) 75
- [3] N. Seiberg, E. Witten, hep-th/9407087, hep-th/9408099
- [4] A. Klemm, W. Lerche, S. Theisen, S. Yankielowicz, hep-th/9411048 ;  
P. Argyres, A. Faraggi, hep-th/9411057;  
A. Hanany, Y. Oz, hep-th/9505074
- [5] A. Klemm, W. Lerche, P. Mayr, C. Vafa, N. Warner, hep-th/9604034
- [6] S. Katz, A. Klemm, C. Vafa, hep-th/9609239
- [7] E. Witten, hep-th/9703166
- [8] R. Dijkgraaf, C. Vafa, hep-th/0206255, hep-th/0207106, hep-th/0208048;  
R. Dijkgraaf, S. Gukov, V. Kazakov, C. Vafa, hep-th/0210238;  
R. Dijkgraaf, M. Grisaru, C. Lam, C. Vafa, D. Zanon, hep-th/0211017;  
M. Aganagic, M. Marino, A. Klemm, C. Vafa, hep-th/0211098;  
R. Dijkgraaf, A. Neitzke, C. Vafa, hep-th/0211194
- [9] N. Nekrasov, hep-th/0206161
- [10] A. Losev, A. Marshakov, N. Nekrasov, hep-th/0302191
- [11] C. Vafa, E. Witten, hep-th/9408074
- [12] J. A. Minahan, D. Nemeschansky, C. Vafa, N.P. Warner, hep-th/9802168;  
T. Eguchi, K. Sakai, hep-th/0203025, hep-th/0211213
- [13] N. Seiberg, E. Witten, hep-th/9908142, JHEP **9909**(1999) 032
- [14] N. Nekrasov, hep-th/9609219 ;  
A. Lawrence, N. Nekrasov, hep-th/9706025
- [15] H. Ooguri, C. Vafa, hep-th/0302109, hep-th/0303063;  
N. Seiberg, hep-th/0305248
- [16] M. Bershadsky, S. Cecotti, H. Ooguri, C. Vafa, hep-th/9309140
- [17] R. Gopakumar, C.Vafa, hep-th/9809187, hep-th/9812127
- [18] A. Marshakov, "Seiberg-Witten Theory and Integrable Systems," *World Scientific*, Singapore 1999;  
H. Braden and I. Krichever, Eds. "Integrability: The Seiberg-Witten and Whitham Equations", *Gordon and Breach* 2000.
- [19] R. Donagi, alg-geom/9705010
- [20] R. Donagi, E. Witten, hep-th/9510101
- [21] H. Nakajima, K. Yoshioka, math.AG/0306198
- [22] A. Belavin, A. Polyakov, A. Schwarz, Yu. Tyupkin, Phys.Lett. **59B** (1975) 85-87
- [23] S. Coleman, "The uses of instantons", *Erice Subnucl.* (1977) 805

- [24] E. Witten, *Comm.Math. Phys.* **117** (1988) 353
- [25] E. Witten, hep-th/9403195
- [26] M. Atiyah, L. Jeffrey, *J. Geom. Phys.* **7** (1990) 119-136
- [27] M. Atiyah, R. Bott, *Phil. Trans. Roy. Soc. London A* **308** (1982), 524-615;  
E. Witten, hep-th/9204083;  
S. Cordes, G. Moore, S. Rangoolam, hep-th/9411210
- [28] N. Ishibashi, H. Kawai, Y. Kitazawa, and A. Tsuchiya, *Nucl. Phys.* **B498** (1997) 467,  
hep-th/9612115
- [29] N. Seiberg, hep-th/0008013
- [30] S. Minwala, M. van Raamsdonk, N. Seiberg, hep-th/9912072
- [31] N. Nekrasov, A. S. Schwarz, hep-th/9802068, *Comm.Math. Phys.* **198** (1998) 689
- [32] A. Okounkov, hep-th/9702001
- [33] K. Johansson, “The longest increasing subsequence in a random permutation and a unitary random matrix model”, *Math. Res. Lett.* 5 (1998), no. 1-2, 63–82;  
J. Baik, P. Deift, K. Johansson, “ On the distribution of the length of the longest increasing subsequence of random permutations”, *J. Amer. Math. Soc.* 12 (1999), no. 4, 1119–1178.;  
A. Okounkov, “Random matrices and random permutations”, *Internat. Math. Res. Notices* 2000, no. 20, 1043–1095;  
A. Borodin, A. Okounkov, G. Olshanski, “Asymptotics of Plancherel measures for symmetric groups”, *J. Amer. Math. Soc.* 13 (2000), no. 3, 481–515;  
K. Johansson, “Discrete orthogonal polynomial ensembles and the Plancherel measure”, *Ann. of Math. (2)* 153 (2001), no. 1, 259–296
- [34] A. Okounkov, “Infinite wedge and random partitions”, *Selecta Math. (N.S.)* 7 (2001), no. 1, 57–81
- [35] P. van Moerbeke, “Integrable lattices: random matrices and random permutations”, *Random matrix models and their applications*, 321–406, *Math. Sci. Res. Inst. Publ.*, 40, Cambridge Univ. Press, Cambridge, 2001.
- [36] A. Okounkov, R. Pandharipande, math.AG/0207233, math.AG/0204305
- [37] S.V. Kerov, “ Interlacing measures”, *Kirillov’s seminar on representation theory*, 35–83, *Amer. Math. Soc. Transl. Ser. 2*, 181, Amer. Math. Soc., Providence, RI, 1998 ;  
S.V. Kerov, “Anisotropic Young diagrams and symmetric Jack functions”, (Russian) *Функционал. Анал. и Приложен.* 34 (2000), no. 1, 51–64, 96; translation in *Funct. Anal. Appl.* 34 (2000), no. 1, 41–51;  
A. M. Vershik, “Hook formulae and related identities”, *Записки сем. ЛОМИ*, **172** (1989), 3-20 (in Russian);  
S. V. Kerov, “Random Young tableaux”, *Теор. вероят. и ее применения*, **3** (1986), 627-628 (in Russian)

- [38] N. Dorey, T.J. Hollowood, V. Khoze, M. Mattis, hep-th/0206063, and references therein
- [39] N. Dorey, V.V. Khoze, M.P. Mattis, hep-th/9607066
- [40] A.Gorsky, I.Krichever, A.Marshakov, A.Mironov and A.Morozov, Phys. Lett. **B355** (1995) 466; hep-th/9505035.
- [41] G. Chan, E. D’Hoker, hep-th/9906193 ;  
E. D’Hoker, I. Krichever, D. Phong, hep-th/9609041
- [42] B.F. Logan, L.A. Shepp, “A variational problem for random Young tableaux”, Advances in Math. 26 (1977), no. 2, 206–222
- [43] S. V. Kerov, A. M. Vershik, “Asymptotics of the Plancherel measure of the symmetric group and the limit shape of the Young diagrams”, ДАН СССР, **233** (1977), no. 6, 1024-1027 (in Russian)
- [44] S. V. Kerov, A. M. Vershik, “Asymptotic behavior of the maximum and generic dimensions of irreducible representations of the symmetric group,” (Russian) Функционал. Анал. и Приложен. **19** (1985), no. 1, 25–36
- [45] S.V. Kerov, “Gaussian limit for the Plancherel measure of the symmetric group”, C. R. Acad. Sci. Paris Sr. I Math. **316** (1993), no. 4, 303–308.
- [46] G. Moore, N. Nekrasov, S. Shatashvili, hep-th/9712241, hep-th/9803265
- [47] R. Kenyon, A. Okounkov, S. Sheffield, “Dimers and amoebae”, to appear ;  
R. Kenyon, A. Okounkov, in preparation
- [48] I. Krichever, hep-th/9205110, Comm.Math. Phys. **143** (1992) 415
- [49] A. Gorsky, A. Marshakov, A. Mironov, A. Morozov, Nucl.Phys. **B527** (1998) 690-716, hep-th/9802007
- [50] M. Mariño, G. Moore, hep-th/9802185;  
J. Edelstein, M. Mariño, J. Mas, hep-th/9805172
- [51] K. Takasaki, hep-th/9901120
- [52] R. Gopakumar, C.Vafa, hep-th/9802016, hep-th/9811131
- [53] M. Douglas, hep-th/9311130, hep-th/9303159
- [54] H. Nakajima, “Lectures on Hilbert Schemes of Points on Surfaces”;  
AMS University Lecture Series, 1999, ISBN 0-8218-1956-9.
- [55] M. Jimbo, T. Miwa, *Solitons and Infinite Dimensional Lie Algebras*, Publ. RIMS Kyoto Univ. **19** ( 1983) 943-1001
- [56] K. Ueno, K. Takasaki, Adv. Studies in Pure Math. **4** (1984) 1
- [57] A. Orlov, nlin.SI/0207030, nlin.SI/0305001
- [58] T. Takebe, “Representation theoretical meaning of the initial value problem for the Toda lattice hierarchy I.”, Lett. Math. Phys. **21** (1991), no. 1, 77–84
- [59] T. Hollowood, hep-th/0201075, hep-th/0202197



- [60] F. Calogero, *J. Math Phys.* **12** (1971) 419;  
 J. Moser, *Adv. Math.* **16**(1975), 197-220;  
 M. Olshanetsky, A. Perelomov, *Inv. Math.* **31** (1976), 93, *Phys. Rev.* **71** (1981) 313;  
 I. Krichever, *Funk. An. Appl.* **14** (1980) 45
- [61] N. Hitchin, *Duke Math. J.* **54**, vol. 1 (1987)
- [62] N. Nekrasov, A. Gorsky, hep-th/9401021 ;  
 N. Nekrasov, hep-th/9503157
- [63] J. Hurtubise, E. Markman, math.AG/9912161
- [64] H. Awata, M. Fukuma, S. Odake, Y.-H. Quano, hep-th/9312208;  
 H.Awata, M.Fukuma, Y.Matsuo, S.Odake, hep-th/9408158;  
 R. Dijkgraaf, hep-th/9609022
- [65] S. Bloch, A. Okounkov, alg-geom/9712009
- [66] R. Dijkgraaf, “Mirror symmetry and elliptic curves”, in: *The moduli space of curves, Proc. of Texel Island Meeting*, Birkhauser, 1994
- [67] J. Hoppe, “Quantum theory of a massless relativistic surface ...” *Elementary Particle Research Journal (Kyoto)* 80 (1989)
- [68] V. Kazakov, I. Kostov, N. Nekrasov, “D-particles, Matrix Integrals and KP hierarchy”, *Nucl. Phys.* **B557** (1999) 413-442, hep-th/9810035
- [69] A. Polyakov, “Gauge fields and strings”, Harwood Academic Publishers, 1987
- [70] H. Braden, N. Nekrasov, hep-th/9912019
- [71] E. Shuryak, *Z. Phys.* **C38** (1988) 165-172, 141-145; *Nucl. Phys.* **B319** (1989) 521, 541,  
*Nucl. Phys.* **B328** (1989) 85,102
- [72] D. Gross, R. Gopakumar, hep-th/9411021;  
 R. Gopakumar, hep-th/0211100
- [73] G. Moore, E. Witten, hep-th/9709193
- [74] A. Losev, N. Nekrasov, S. Shatashvili, hep-th/9711108, hep-th/9801061
- [75] H. Kawai, T. Kuroki, T. Morita, hep-th/0303210
- [76] F. Cachazo, M. Douglas, N. Seiberg, E. Witten, hep-th/0211170
- [77] N. Nekrasov, S. Shatashvili, in progress
- [78] M. Douglas, V. Kazakov, hep-th/9305047
- [79] D. Gross, hep-th/9212149;  
 D. Gross, W. Taylor, hep-th/9301068, hep-th/9303046
- [80] A. Iqbal, hep-th/0212279
- [81] M. Aganagic, M. Mariño, C. Vafa, hep-th/0206164
- [82] P. Wiegmann, A. Zabrodin, hep-th/9909147;  
 I.K. Kostov, I. Krichever, M. Mineev-Weinstein, P. Wiegmann, A. Zabrodin, hep-th/0005259

- [83] V. Pasquier, hep-th/9405104;  
R. Caracciolo, A. Lerda, G.R. Zemba, hep-th/9503229;  
J. Minahan, A.P. Polychronakos, hep-th/9404192, hep-th/9303153;  
A.P. Polychronakos, hep-th/9902157;  
E. Langmann, math-ph/0007036, math-ph/0102005
- [84] S. Girvin, cond-mat/9907002
- [85] V. Knizhnik, A. Zamolodchikov, Nucl. Phys. **B247** (1984) 83-103
- [86] D. Bernard, Nucl. Phys. **B303** (1988) 77-93, Nucl. Phys. **B309** (1988) 145-174
- [87] A. S. Losev, CERN-TH-6215-91, Aug. 1991
- [88] G. Felder, hep-th/9609153
- [89] D. Ivanov, hep-th/9610207
- [90] M.A.Olshanetsky, "Painlevé type equations and Hitchin systems", in [18]
- [91] C. Vafa, hep-th/0008142